

PART NUMBER	REVISION	DESCRIPTION	FEED TYPE
2151543-1	H	FINE CRIMP HEIGHT ADJUST	MECHANICAL
2151543-2	H	FINE CRIMP HEIGHT ADJUST	PNEUMATIC
5-2151543-1	H	SEAL STRIPPER CRIMPER TERMINATING UNIT	MECHANICAL
5-2151543-2	H	SEAL STRIPPER CRIMPER TERMINATING UNIT	PNEUMATIC
7-2151543-1	H	MECHANICAL AND CRIMP TOOLING KIT	MECHANICAL
7-2151543-2	H	PNEUMATIC AND CRIMP TOOLING KIT	PNEUMATIC
7-2151543-7	C	CRIMP TOOLING KIT	-

ATLANTIC VERSION TERMINATOR INTERFACE ADAPTER

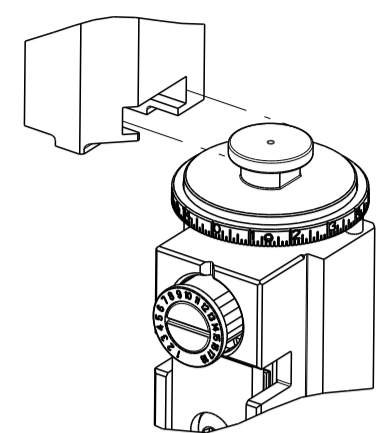

APPLICATOR DATA		
CRIMP	SIZE	TYPE
WIRE	1.57 mm [.062]	F
INSUL	1.86 mm [.073]	O

APPLICATOR INSTRUCTIONS 408-35042

TERMINAL DATA: MOLEX TERMINAL		MOLEX CRIMP SPECIFICATION	
TERMINAL NAME: TERMINAL			
WIRE STRIP LENGTH	INSULATION DIAMETER RANGE		
4.70-5.60 mm [1.85-.220 IN]	Ø1.40-1.65 mm [0.055-.065 IN]		
TERMINAL APPLICATION SPECIFICATION	AS-33012-002		
TERMINALS APPLIED			
TE TERMINAL	MOLEX TERMINAL	TE TERMINAL	MOLEX TERMINAL
2113245-1	33012-3003	2113245-5	33001-5003
2113245-2	33012-3023	2113245-6	33001-3023
2113245-3	34750-1003	2113245-7	33001-5023
2113245-4	33001-3005		

WIRE SIZE	CRIMP HEIGHT mm [INCH]	CRIMP HEIGHT REFERENCE SETTING
0.50mm2	1.10 +/- 0.05 [0.043 +/- .002]	7.8
22 AWG	1.00 +/- 0.05 [0.039 +/- .002]	8.6
0.35mm2	0.95 +/- 0.05 [0.037 +/- .002]	9.1

- 1 RECOMMENDED SPARE PARTS
- 2 REFER TO SUPPLIED INSTRUCTION SHEET FOR CLEANING, LUBRICATION AND STORAGE OF APPLICATOR.
- 3 APPLY PART NUMBER 2-23419-6 LOCTITE TO THREADS OF ITEM 242. APPLY PART NUMBER 1-23419-5 LOCTITE TO THREADS OF ITEM 180.
- 4 CRIMP HEIGHT REFERENCE SETTING WAS THE SETTING USED WHEN THE APPLICATOR WAS QUALIFIED AT THE FACTORY. ADJUSTMENT MAY BE NECESSARY WHEN RUNNING APPLICATOR IN THE FIELD.
- 5. UNLESS SPECIFIED OTHERWISE TORQUE VALUES SHALL BE USED PER DOCUMENT, 101-35000.
- 6 TERMINAL LUBRICANT IS RECOMMENDED.

***WARNING**
ON INSTALLATION, SET WIRE DISC TO CRIMP HEIGHT REFERENCE SETTING FOR LARGEST WIRE SIZE. CRIMP HEIGHT REFERENCE SETTINGS GREATER THAN THE VALUE SHOWN MAY CAUSE DAMAGE TO THE CRIMP TOOLING, REFER TO THE INSTRUCTION SHEET FOR PROPER SETUP AND ADJUSTMENTS.

ATLANTIC VERSION
Shown on sheets 1 of 4 & 2 of 4
(Pacific version shown on sheets 3 of 4 & 4 of 4)

LOC	DIST	REVISIONS					
A	66	P	LTN	DESCRIPTION	DATE	OWN	APVD
		E		ECR-18-018367	23NOV2018	FZ	KZ
		F		ECR-20-015233	26OCT2020	TB	RR
		G		ECR-20-017555	10DEC2020	TB	TE
		H		ECR-22-152586	15SEP2022	FZ	JAH

-	2	2	2	2	2	2	2168083-1	SCR, SKT HD CAP, RoHS, M3 X 8.0	306
-	1	1	1	1	1	1	2-690438-2	FRONT STRIP GUIDE	305
-	1	1	1	1	1	1	980371-4	SCR, SKT HD SHLDR 5.0 DIA X 6.0	304
-	1	1	1	1	1	1	356835-1	LEVER, DRAG RELEASE	303
-	2	2	2	2	2	2	2-18032-5	SCR, SET, FLT PNT, M5 X 20.0	302
-	1	1	1	1	1	1	240792-1	DRAG, TERMINAL	301
-	2	2	2	2	2	2	22283-1	SPRING, COMPRESSION	300
-	-	-	1	1	-	-	1803515-3	RAM ASSEMBLY, SF ATLANTIC	293
-	-	-	1	1	-	-	2-1803583-1	APPLICATOR BASIC ASSEMBLY, SF	292
-	2	2	2	2	2	2	2168083-1	SCR, SKT HD CAP, RoHS, M3 X 8.0	269
-	1	1	1	1	1	1	1633782-3	FENCE	267
-	1	-	1	-	1	-	2119641-1	FEED CAM, AIR FEED	248
-	1	1	1	1	1	1	2119082-8	CAM, SNAIL, INSULATION ADJUSTMENT	244
-	1	1	1	1	1	1	2079764-1	WASHER, WAVE SPRING, CREST-TO-CREST	243
-	1	1	1	1	1	1	2119083-1	RETAINER, INSULATION DIAL	242
-	1	1	1	1	1	1	7-18023-7	SCR, SKT HD CAP M3 X 4.0	241
-	-	1	-	1	-	1	2119580-1	MECHANICAL FEED ASSEMBLY	239
-	1	-	1	-	1	-	2844940-1	AIR FEED MODULE	238
-	-	-	1	1	-	-	4-1722335-3	STRIPPER, SIDE FEED	182
-	-	-	1	1	-	-	1-5018030-0	NUT, HEX, REG, RoHS, M3.5	181
-	-	-	1	1	-	-	1-1752354-9	STANDOFF,HOLD-DOWN	180
-	-	-	1	1	-	-	993111-1	PIN, SLOTTED SPRING 3.0 X 20.0	177
-	-	-	1	1	-	-	5-22280-0	SPRING, COMPRESSION	176
-	-	-	1	1	-	-	1752353-3	GUIDE PIN,HOLDDOWN	175
-	-	-	1	1	-	-	1901680-2	GUIDE PIN,HOLDDOWN	174
-	REF	REF	REF	REF	REF	REF	994970-2	COUNTER, MAGNETIC	164
-	1	1	1	1	1	1	1-18028-2	WASHER, FLAT, REG M4	119
-	1	1	1	1	1	1	2119955-1	ASSY, LUBRICATOR, SIDE FEED	113
-	1	1	1	1	1	1	2844908-1	SCREW, LOCKING	99
-	1	1	1	1	1	1	2844907-1	POST, LOCKING	98
-	1	1	1	1	1	1	455888-4	SPACER, CRIMPER	82
-	1	1	1	1	1	1	1803607-3	DOCUMENTATION PACKAGE	71
-	1	1	1	1	1	1	2119791-9	DEPRESSOR, WIRE	70
-	1	1	1	1	1	1	2119740-1	TAG, IDENTIFICATION	67
-	2	2	2	2	2	2	2168078-1	SCREW, DRIVE, RH, RoHS, 2 x .188	66
-	1	1	1	1	1	1	2168083-2	SCR, SKT HD CAP, RoHS, M4 X 8.0	60
-	1	1	1	1	1	1	5-18022-5	SCR, HEX HD CAP, M4 X 6.0	59
-	1	1	1	1	1	1	1338685-1	PAWL, FEED	56
-	4	4	4	4	4	4	2168083-3	SCR, SKT HD CAP, RoHS, M4 X 12.0	54
-	2	2	2	2	2	2	1-2168083-0	SCR, SKT HD CAP, RoHS, M4 X 10	53
-	1	1	1	1	1	1	1803382-6	HOLD DOWN, SPRING LOADED	50
-	1	2	1	2	1	2	18023-9	SCR, SKT HD CAP M4 X 6.0	49
-	-	1	-	1	-	1	2119652-1	FEED CAM, PRE FEED	48
-	-	1	-	1	-	1	2119653-1	FEED CAM, POST FEED	47
-	1	1	-	-	1	1	1803583-9	APPLICATOR BASIC ASSEMBLY, SF	46
-	1	1	-	-	1	1	1803515-1	RAM ASSEMBLY, SF ATLANTIC	44
-	1	1	1	1	1	1	1803602-1	SCR, BHSC, RoHS (M8 X 25)	41
-	1	1	1	1	1	1	2-1752356-0	SUPPORT, TERMINAL	34
-	2	2	2	2	2	2	2079383-5	SCR, BHSC, RoHS (M4 X 20)	33
-	2	2	2	2	2	2	2-2844962-7	SPACER, CYLINDRICAL, STRIP GUIDE	30
-	1	1	1	1	1	1	2844992-3	ASSEMBLY, STRIP GUIDE	29
-	1	1	1	1	1	1	1-455888-0	SPACER, CRIMPER	28
-	1	1	1	1	1	1	1320928-2	STRIP GUIDE	24
-	1	1	-	-	1	1	2168083-2	SCR, SKT HD CAP, RoHS, M4 X 8.0	21
-	2	2	1	1	2	2	1-18028-2	WASHER, FLAT, REG M4	20
-	1	1	-	-	1	1	2119533-1	STRIPPER, SIDE FEED	19
-	1	1	1	1	1	1	2119806-1	INSERT, SHEAR	13
-	1	1	1	1	1	1	3-22280-3	SPRING, COMPRESSION	12
-	1	1	1	1	1	1	1-356885-4	STOP, SHEAR	11
-	1	1	1	1	1	1	2119805-1	SHEAR HOLDER, FRONT	10
-	1	1	1	1	1	1	1803095-5	FLOATING SHEAR, FRONT	9
-	1	2	2	1	1	1	1633918-2	ANVIL, COMBINATION	8
-	1	1	1	1	1	1	2-240641-8	SPACER	7
-	-	-	-	-	-	-	-	-	6
-	1	1	1	1	1	1	2119757-4	DEPRESSOR, SHEAR	5
-	1	1	1	1	1	1	4-238011-0	BLOCK, CRIMPER SPACER	4
-	1	2	2	1	1	1	1633966-8	CRIMPER, INSULATION O	3
-	1	1	1	1	1	1	455888-7	SPACER, CRIMPER	2
-	1	2	2	1	1	1	3-456403-8	CRIMPER, WIRE PREMIUM	1

ITEM NO	PART NO	DESCRIPTION	ITEM NO
-77	-72	-71	-52
-51	-2	-1	

THIS DRAWING IS UNPUBLISHED. RELEASED FOR PUBLICATION BY TYCO ELECTRONICS CORPORATION. ALL RIGHTS RESERVED. COPYRIGHT 20 BY TYCO ELECTRONICS CORPORATION. ALL RIGHTS RESERVED.	OWN Y. YIN 21DEC2011 CHK G. BAILEY 21DEC2011 APVD S. XI 21DEC2011	TE Connectivity Harrisburg, PA 17105-3608
DIMENSIONS: mm	TOLERANCES UNLESS OTHERWISE SPECIFIED: 0 PLC ± 1 PLC ± 3 PLC ± 4 PLC ± ANGLES ±	NAME Ocean Side Feed Applicator
MATERIAL	FINISH	SIZE CAGE CODE DRAWING NO RESTRICTED TO A1 00779 C=2151543
Customer Accessible Production Drawing		SCALE 1:2 SHEET 1 OF 4 REV H

LOC	DIST	REVISIONS					
A	66	P	LYN	DESCRIPTION	DATE	OWN	APVD
		-		SEE SHEET 1	-	-	-

FEED TYPE MECHANICAL

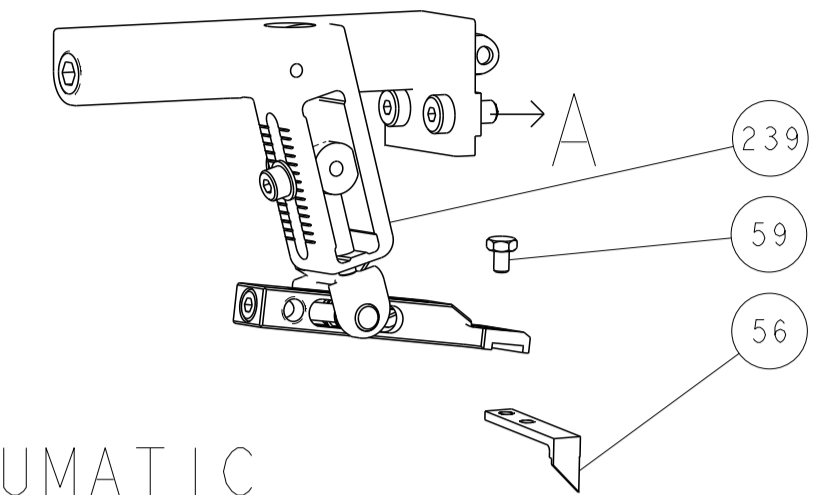

PNEUMATIC

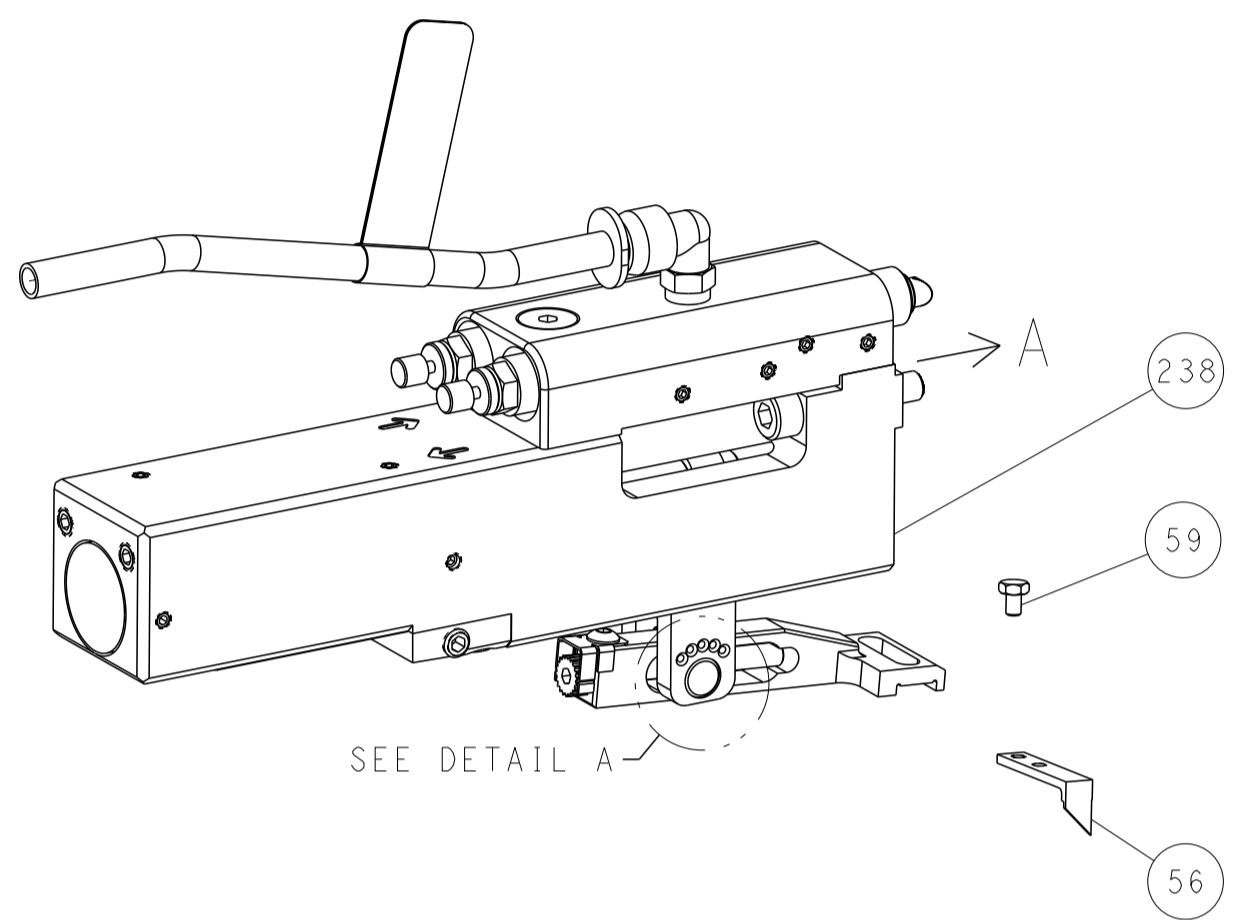

FEED SPRING SETTING POSITION (SHOWN FROM REAR SIDE)



DETAIL A

CAM POSITIONS

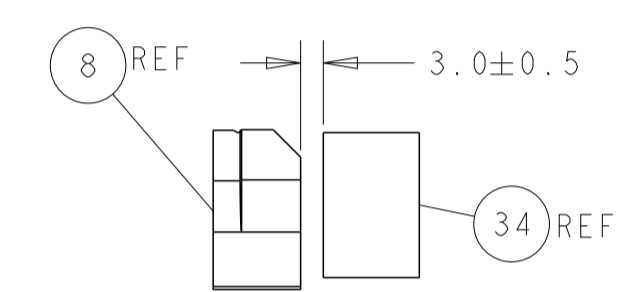
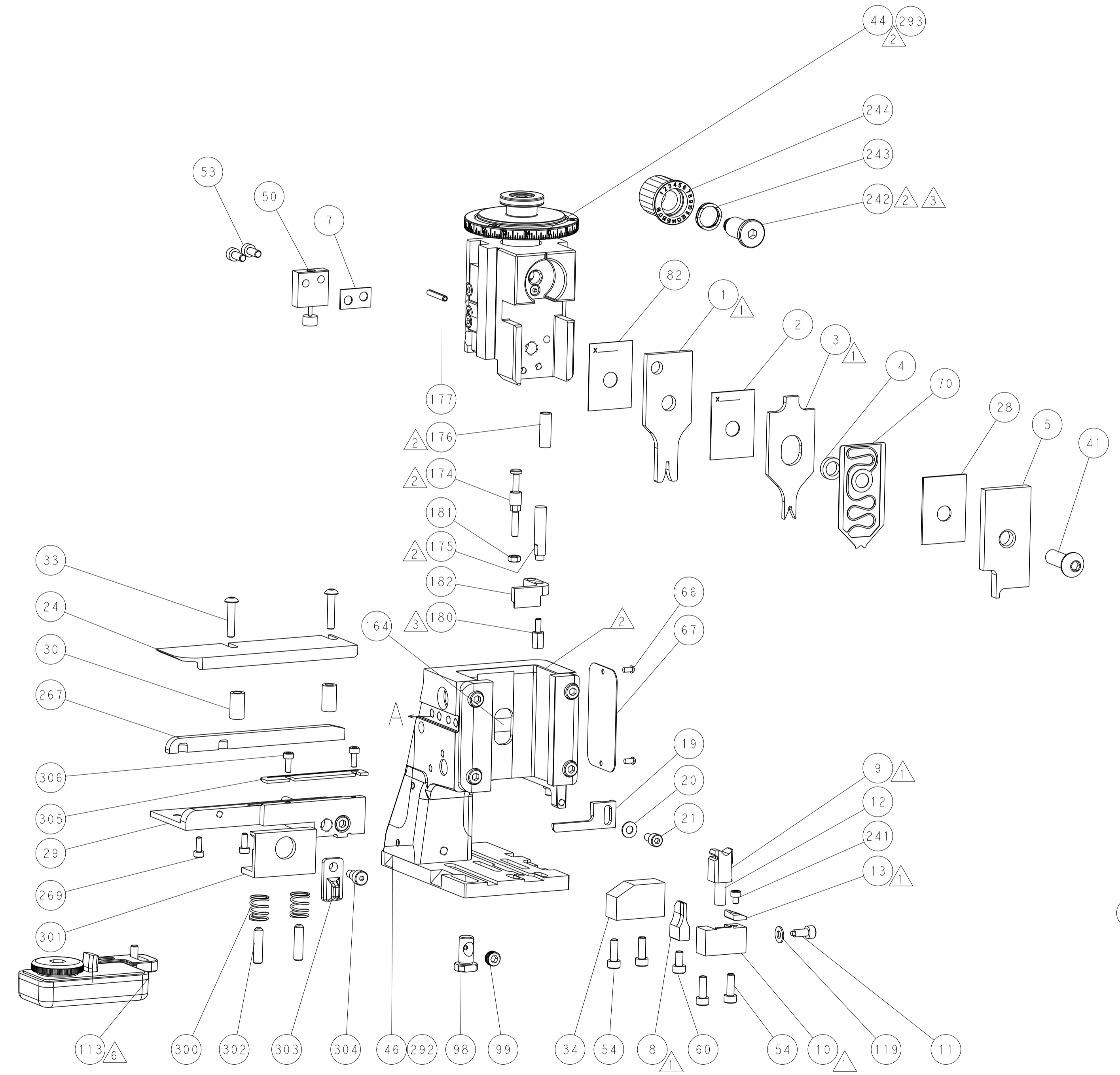
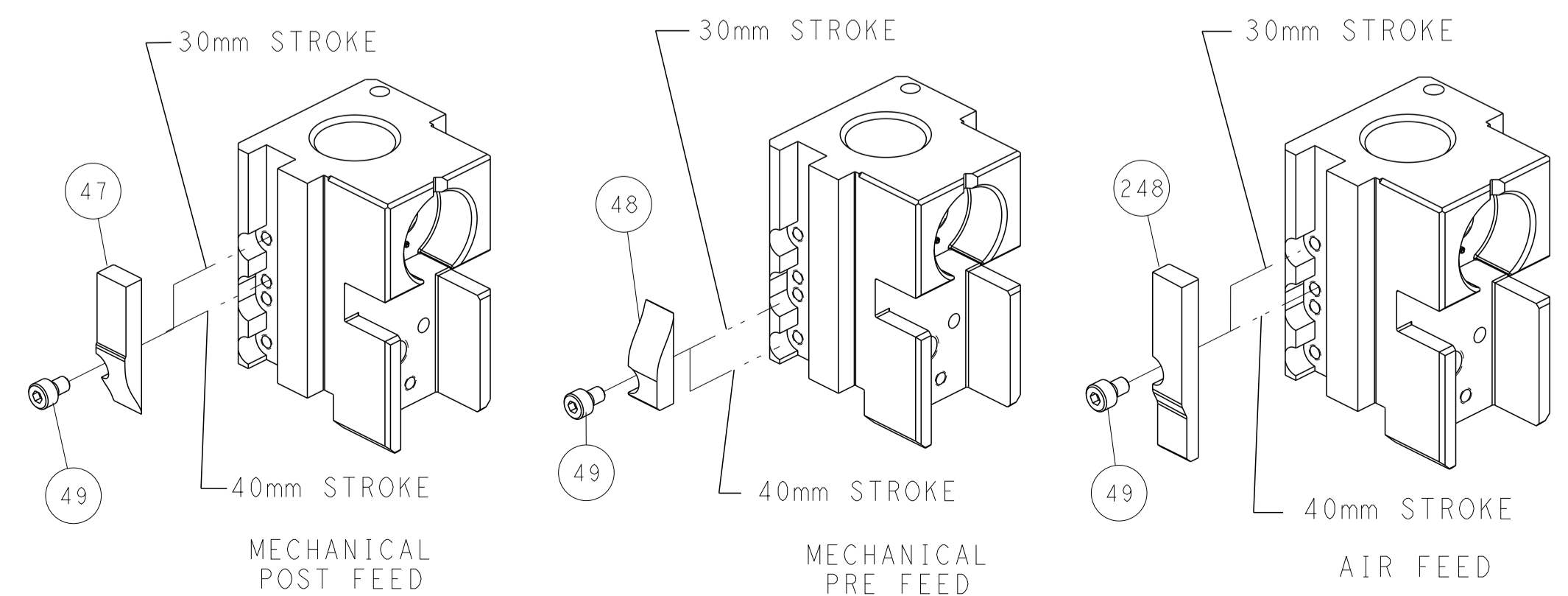

TERMINAL SUPPORT LOCATION

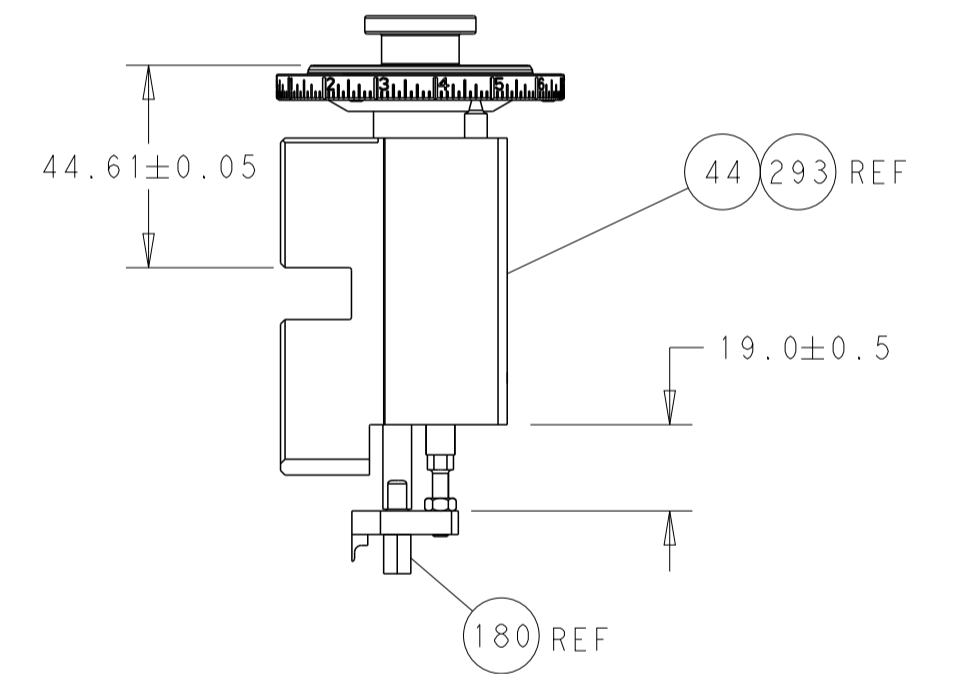

RAM & HOLD DOWN SET-UP

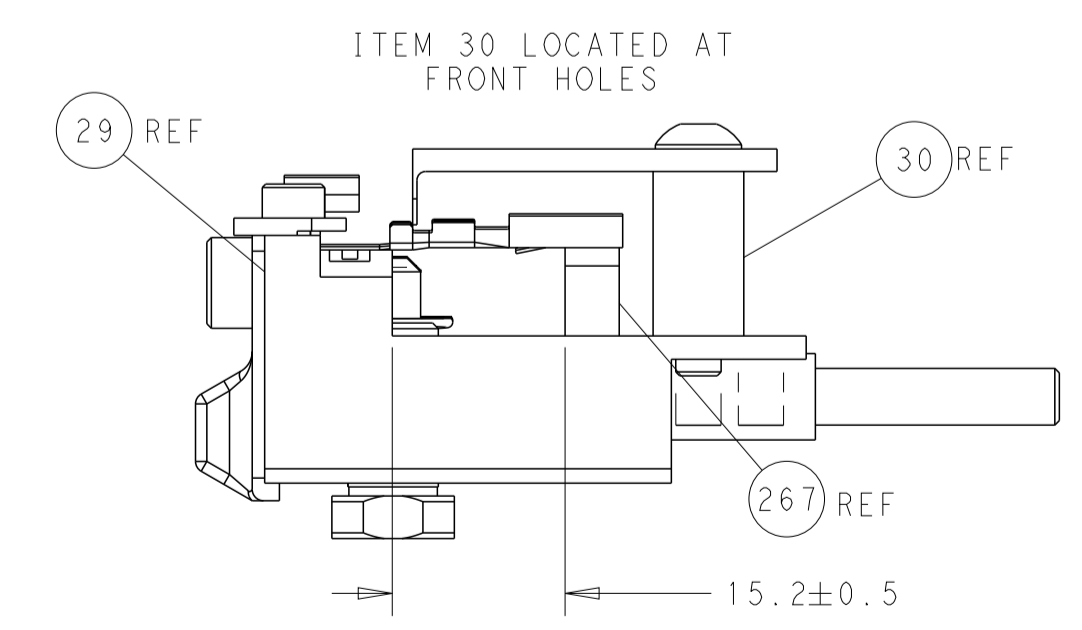

FEED TRACK POSITION GUIDE BY INSULATION BARREL

ATLANTIC VERSION
 Shown on sheets 1 of 4 & 2 of 4
 (Pacific version shown on sheets 3 of 4 & 4 of 4)

DIMENSIONS:		TOLERANCES UNLESS OTHERWISE SPECIFIED:		DWN Y. YIN 21DEC2011		TE Connectivity	
mm	0 PLC ±	1 PLC ±	2 PLC ±	3 PLC ±	4 PLC ±	Harrisburg, PA 17105-3608	
MATERIAL:		FINISH:		CHK G. BAILEY 21DEC2011		NAME Ocean Side Feed Applicator	
				APVD S. XI 21DEC2011		SIZE CAGE CODE DRAWING NO RESTRICTED TO	
				PRODUCT SPEC		A1 00779 ©=2151543	
				APPLICATION SPEC		Customer Accessible Production Drawing	
				WEIGHT		SCALE 1:2 SHEET 2 OF 4 REV H	

PART NUMBER	REVISION	DESCRIPTION	FEED TYPE
2-2151543-1	H	FINE CRIMP HEIGHT ADJUST	MECHANICAL
2-2151543-2	H	FINE CRIMP HEIGHT ADJUST	PNEUMATIC
7-2151543-7	C	CRIMP TOOLING KIT	-

PACIFIC VERSION TERMINATOR
 INTERFACE ADAPTER



APPLICATOR DATA		
CRIMP	SIZE	TYPE
WIRE	1.57 mm [.062]	F
INSUL	1.86 mm [.073]	O
APPLICATOR INSTRUCTIONS 408-35042		

TERMINAL DATA: MOLEX TERMINAL MOLEX CRIMP SPECIFICATION			
TERMINAL NAME: TERMINAL			
WIRE STRIP LENGTH 4.70-5.60 mm [1.85-.220 IN]		INSULATION DIAMETER RANGE Ø1.40-1.65 mm [.055-.065 IN]	
TERMINAL APPLICATION SPECIFICATION AS-33012-002			
TERMINALS APPLIED			
TE TERMINAL	MOLEX TERMINAL	TE TERMINAL	MOLEX TERMINAL
2113245-1	33012-3003	2113245-5	33001-5003
2113245-2	33012-3023	2113245-6	33001-3023
2113245-3	34750-1003	2113245-7	33001-5023
2113245-4	33001-3005		

WIRE SIZE	CRIMP HEIGHT mm [INCH]	CRIMP HEIGHT REFERENCE SETTING
0.50mm2	1.10+/-0.05 [1.043+/-0.002]	7.8
22 AWG	1.00+/-0.05 [1.039+/-0.002]	8.6
0.35mm2	0.95+/-0.05 [1.037+/-0.002]	9.1

- 1 RECOMMENDED SPARE PARTS
- 2 REFER TO SUPPLIED INSTRUCTION SHEET FOR CLEANING, LUBRICATION AND STORAGE OF APPLICATOR.
- 3 APPLY PART NUMBER 2-23419-6 LOCTITE TO THREADS OF ITEM 242.
- 4 CRIMP HEIGHT REFERENCE SETTING WAS THE SETTING USED WHEN THE APPLICATOR WAS QUALIFIED AT THE FACTORY. ADJUSTMENT MAY BE NECESSARY WHEN RUNNING APPLICATOR IN THE FIELD.
- 5. UNLESS SPECIFIED OTHERWISE TORQUE VALUES SHALL BE USED PER DOCUMENT, 101-35000.
- 6 TERMINAL LUBRICANT IS RECOMMENDED.

***WARNING**
 ON INSTALLATION, SET WIRE DISC TO CRIMP HEIGHT REFERENCE SETTING FOR LARGEST WIRE SIZE. CRIMP HEIGHT REFERENCE SETTINGS GREATER THAN THE VALUE SHOWN MAY CAUSE DAMAGE TO THE CRIMP TOOLING, REFER TO THE INSTRUCTION SHEET FOR PROPER SETUP AND ADJUSTMENTS.

PACIFIC VERSION
 Shown on sheets 3 of 4 & 4 of 4
 (Atlantic version shown on sheets 1 of 4 & 2 of 4)

LOC	DIST	REVISIONS					
A	66	P	LTN	DESCRIPTION	DATE	OWN	APVD
-	-	-	-	SEE SHEET 1	-	-	-

-	2	2	2168083-1	SCR, SKT HD CAP, RoHS, M3 X 8.0	306
-	1	1	2-690438-2	FRONT STRIP GUIDE	305
-	1	1	980371-4	SCR, SKT HD SHLDR 5.0 DIA X 6.0	304
-	1	1	356835-1	LEVER, DRAG RELEASE	303
-	2	2	2-18032-5	SCR, SET, FLT PNT, M5 X 20.0	302
-	1	1	240792-1	DRAG, TERMINAL	301
-	2	2	22283-1	SPRING, COMPRESSION	300
-	2	2	2168083-1	SCR, SKT HD CAP, RoHS, M3 X 8.0	269
-	1	1	1633782-3	FENCE	267
-	1	1	2119082-8	CAM, SNAIL, INSULATION ADJUSTMENT	244
-	1	1	2079764-1	WASHER, WAVE SPRING, CREST-TO-CREST	243
3	-	1	2119083-1	RETAINER, INSULATION DIAL	242
-	1	1	7-18023-7	SCR, SKT HD CAP M3 X 4.0	241
-	-	1	2119580-1	MECHANICAL FEED ASSEMBLY	239
-	1	-	2844940-1	AIR FEED MODULE	238
-	REF	REF	994970-2	COUNTER, MAGNETIC	164
-	1	-	2119641-2	FEED CAM, AIR FEED	151
-	1	1	2168083-8	SCR, SKT HD CAP, RoHS, M4 X 16	144
-	4	4	2168083-9	SCR, SKT HD CAP, RoHS, M4 X 20	143
-	-	1	2119653-2	FEED CAM, POST FEED	142
-	1	1	1-1803583-0	APPLICATOR BASIC ASSEMBLY, SF	141
-	1	1	1803516-1	RAM ASSEMBLY, SF PACIFIC	140
-	1	1	1-18028-2	WASHER, FLAT, REG M4	119
6	-	1	2119955-1	ASSY, LUBRICATOR, SIDE FEED	113
-	1	1	2844908-1	SCREW, LOCKING	99
-	1	1	2844907-1	POST, LOCKING	98
-	1	1	455888-4	SPACER, CRIMPER	82
-	1	1	1803607-3	DOCUMENTATION PACKAGE	71
-	1	1	2119791-9	DEPRESSOR, WIRE	70
-	1	1	2119740-1	TAG, IDENTIFICATION	67
-	2	2	2168078-1	SCREW, DRIVE, RH, RoHS, 2 x .188	66
-	1	1	5-18022-5	SCR, HEX HD CAP, M4 X 6.0	59
-	1	1	1338685-1	PAWL, FEED	56
-	2	2	1-2168083-0	SCR, SKT HD CAP, RoHS, M4 X 10	53
-	1	1	1803382-6	HOLD DOWN, SPRING LOADED	50
-	1	2	18023-9	SCR, SKT HD CAP M4 X 6.0	49
-	-	1	2119652-1	FEED CAM, PRE FEED	48
-	1	1	1803602-1	SCR, BHSC, RoHS (M8 X 25)	41
-	1	1	2-1752356-0	SUPPORT, TERMINAL	34
-	2	2	2079383-5	SCR, BHSC, RoHS (M4 X 20)	33
-	2	2	2-2844962-7	SPACER, CYLINDRICAL, STRIP GUIDE	30
-	1	1	2844992-3	ASSEMBLY, STRIP GUIDE	29
-	1	1	1-455888-0	SPACER, CRIMPER	28
-	1	1	1320928-2	STRIP GUIDE	24
-	1	1	2168083-2	SCR, SKT HD CAP, RoHS, M4 X 8.0	21
-	1	1	1-18028-2	WASHER, FLAT, REG M4	20
-	1	1	2119533-1	STRIPPER, SIDE FEED	19
1	-	1	2119806-1	INSERT, SHEAR	13
-	1	1	3-22280-3	SPRING, COMPRESSION	12
-	1	1	1-356885-4	STOP, SHEAR	11
1	-	1	2119805-1	SHEAR HOLDER, FRONT	10
1	-	1	1803095-5	FLOATING SHEAR, FRONT	9
1	1	1	1633918-2	ANVIL, COMBINATION	8
-	1	1	2-240641-8	SPACER	7
-	-	-	-	-	6
-	1	1	2119757-4	DEPRESSOR, SHEAR	5
-	1	1	4-238011-0	BLOCK, CRIMPER SPACER	4
1	1	1	1633966-8	CRIMPER, INSULATION O	3
-	1	1	455888-7	SPACER, CRIMPER	2
1	1	1	3-456403-8	CRIMPER, WIRE PREMIUM	1

DIMENSIONS:		TOLERANCES UNLESS OTHERWISE SPECIFIED:		DWG		REV	
mm	0 PLC ±	1 PLC ±	2 PLC ±	Y. YIN	21DEC2011	Y. YIN	21DEC2011
	3 PLC ±	4 PLC ±	ANGLES ±	G. BAILEY	21DEC2011	G. BAILEY	21DEC2011
	FINISH			S. XI	21DEC2011	S. XI	21DEC2011
MATERIAL				PRODUCT SPEC			
				APPLICATION SPEC			
				WEIGHT			
				SCALE	1:2	SHEET	3 OF 4
				REV	H		

