

PART NUMBER	REVISION	DESCRIPTION	FEED TYPE
2266814-1	B	FINE CRIMP HEIGHT ADJUST	MECHANICAL
2266814-2	B	FINE CRIMP HEIGHT ADJUST	PNEUMATIC
7-2266814-1	B	MECHANICAL AND CRIMP TOOLING KIT	MECHANICAL
7-2266814-2	B	PNEUMATIC AND CRIMP TOOLING KIT	PNEUMATIC
7-2266814-7	A	CRIMP TOOLING KIT	-

ATLANTIC VERSION TERMINATOR INTERFACE ADAPTER

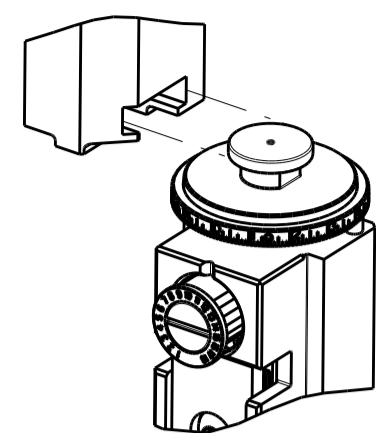

APPLICATOR DATA		
CRIMP	SIZE	TYPE
WIRE	1.47 mm [.058]	F
INSUL	1.65 mm [.065]	F

APPLICATOR INSTRUCTIONS 408-35042

TERMINAL DATA: JST TERMINAL		JST CRIMP SPECIFICATION	
TERMINAL NAME: TERMINAL			
WIRE STRIP LENGTH		INSULATION DIAMETER RANGE	
2.30-3.10 mm [.091-.122 IN]		Ø1.20-1.80 mm [.047-.071 IN]	
TERMINAL APPLICATION SPECIFICATION H4009/017-00 Rev 01-29-01			
TERMINALS APPLIED			
TE TERMINAL	JST TERMINAL	TE TERMINAL	JST TERMINAL
286860-1	SHF-001T-0.8BS	286860-4	SHF-001-0.8BS
286860-2	SHF-001T-0.8SS	286860-5	SHF-001G1-0.8BS
286860-3	SHF-001-0.8SS		

WIRE SIZE	CRIMP HEIGHT mm [INCH]	CRIMP HEIGHT REFERENCE SETTING
22 AWG	0.80 +/- 0.05 [.031 +/- .002]	5.1
24 AWG	0.75 +/- 0.05 [.030 +/- .002]	5.6
26 AWG	0.70 +/- 0.05 [.028 +/- .002]	6.2
28 AWG	0.68 +/- 0.025 [.027 +/- .001]	6.4

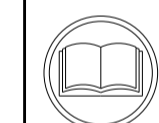

- △ RECOMMENDED SPARE PARTS
- △ REFER TO SUPPLIED INSTRUCTION SHEET FOR CLEANING, LUBRICATION AND STORAGE OF APPLICATOR.
- △ APPLY PART NUMBER 2-23419-6 LOCTITE TO THREADS OF ITEM 242.
- △ CRIMP HEIGHT REFERENCE SETTING WAS THE SETTING USED WHEN THE APPLICATOR WAS QUALIFIED AT THE FACTORY. ADJUSTMENT MAY BE NECESSARY WHEN RUNNING APPLICATOR IN THE FIELD.
- 5. UNLESS SPECIFIED OTHERWISE TORQUE VALUES SHALL BE USED PER DOCUMENT, 101-35000.

**\*WARNING**  
ON INSTALLATION, SET WIRE DISC TO CRIMP HEIGHT REFERENCE SETTING FOR LARGEST WIRE SIZE. CRIMP HEIGHT REFERENCE SETTINGS GREATER THAN THE VALUE SHOWN MAY CAUSE DAMAGE TO THE CRIMP TOOLING, REFER TO THE INSTRUCTION SHEET FOR PROPER SETUP AND ADJUSTMENTS.

LOC	DIST	REVISIONS					
		P	LTN	DESCRIPTION	DATE	OWN	APVD
A	66			RELEASED	11AUG2015	GH	GB
				ECR-18-016638	22OCT2018	MZ	KZ

-	1	-	1	-	2119640-1	PUSH ROD, AIR FEED	250
-	1	-	1	-	1803259-1	BUSHING, FLANGED	249
-	1	-	1	-	2119641-1	FEED CAM, AIR FEED	248
-	1	1	1	1	2119082-4	CAM, SNAIL, INSULATION ADJUSTMENT	244
-	1	1	1	1	2079764-1	WASHER, WAVE SPRING, CREST-TO-CREST	243
-	1	1	1	1	2119083-1	RETAINER, INSULATION DIAL	242
-	1	1	1	1	7-18023-7	SCR, SKT HD CAP M3 X 4.0	241
-	-	1	-	1	2119580-1	MECHANICAL FEED ASSEMBLY	239
-	1	-	1	-	2063440-1	AIR FEED MODULE	238
-	2	-	2	-	21045-3	RING, RETAIN, EXTERN, 3/16 CRESCENT	172
-	REF	REF	REF	REF	994970-2	COUNTER, MAGNETIC	164
-	1	-	1	-	240638-1	SPRING, FEED FINGER	163
-	1	-	1	-	3-23627-7	PIN, RETAIN, GRVD, 3/16 X .854	137
-	1	-	1	-	2119799-1	HOLDER, FEED FINGER, AF	136
-	1	1	1	1	2844908-1	SCREW, LOCKING	99
-	1	1	1	1	2844907-1	POST, LOCKING	98
-	1	1	1	1	455888-5	SPACER, CRIMPER	82
-	1	1	1	1	1803607-1	DOCUMENTATION PACKAGE	71
-	1	1	1	1	2119791-5	DEPRESSOR, WIRE	70
-	1	1	1	1	2119740-1	TAG, IDENTIFICATION	67
-	2	2	2	2	2168078-1	SCREW, DRIVE, RH, RoHS, 2 x .188	66
-	1	1	1	1	2168083-2	SCR, SKT HD CAP, RoHS, M4 X 8.0	60
-	1	1	1	1	5-18022-5	SCR, HEX HD CAP, M4 X 6.0	59
-	1	1	1	1	1338685-1	PAWL, FEED	56
-	4	4	4	4	2168083-3	SCR, SKT HD CAP, RoHS, M4 X 12.0	54
-	1	2	1	2	18023-9	SCR, SKT HD CAP M4 X 6.0	49
-	-	1	-	1	2119652-1	FEED CAM, PRE FEED	48
-	-	1	-	1	2119653-1	FEED CAM, POST FEED	47
-	1	1	1	1	1803583-9	APPLICATOR BASIC ASSEMBLY, SF	46
-	1	1	1	1	1803515-1	RAM ASSEMBLY, SF ATLANTIC	44
-	1	1	1	1	1803602-1	SCR, BHSC, RoHS (M8 X 25)	41
-	1	1	1	1	2-1752356-5	SUPPORT, TERMINAL	34
-	2	2	2	2	2079383-5	SCR, BHSC, RoHS (M4 X 20)	33
-	2	2	2	2	2-2844962-6	SPACER, CYLINDRICAL, STRIP GUIDE	30
-	1	1	1	1	2844992-1	ASSEMBLY, STRIP GUIDE	29
-	1	1	1	1	1320928-2	STRIP GUIDE	24
-	1	1	1	1	2168083-2	SCR, SKT HD CAP, RoHS, M4 X 8.0	21
-	2	2	2	2	1-18028-2	WASHER, FLAT, REG M4	20
-	1	1	1	1	2119533-1	STRIPPER, SIDE FEED	19
-	1	1	1	1	2119806-1	INSERT, SHEAR	13
-	1	1	1	1	3-22280-3	SPRING, COMPRESSION	12
-	1	1	1	1	1-356885-4	STOP, SHEAR	11
-	1	1	1	1	2119805-1	SHEAR HOLDER, FRONT	10
-	1	1	1	1	1803095-3	FLOATING SHEAR, FRONT	9
1	2	2	1	1	5-1803171-0	ANVIL, COMBINATION	8
-	-	-	-	-	-	-	7
-	-	-	-	-	-	-	6
-	1	1	1	1	2119757-5	DEPRESSOR, SHEAR	5
-	1	1	1	1	238011-8	BLOCK, CRIMPER SPACER	4
1	2	2	1	1	9-1633962-5	CRIMPER, INSULATION F PREMIUM	3
-	1	1	1	1	455888-1	SPACER, CRIMPER	2
1	2	2	1	1	8-1633730-3	CRIMPER, WIRE	1

ATLANTIC VERSION  
Shown on sheets 1 of 4 & 2 of 4  
(Pacific version shown on sheets 3 of 4 & 4 of 4)

DIMENSIONS:		TOLERANCES UNLESS OTHERWISE SPECIFIED:		MATERIAL:		FINISH:	
mm	0 PLC ±	1 PLC ±	2 PLC ±	3 PLC ±	4 PLC ±	ANGLES ±	

CHK	STAKEM	12JUNE2015	TE Connectivity
CHK	G. BAILEY	12JUNE2015	Harrisburg, PA 17105-3608
APVD	T. ELBIN	12JUNE2015	
NAME		Ocean Side Feed Applicator	
SIZE	CAGE CODE	DRAWING NO	RESTRICTED TO
A1	00779	2266814	
Customer Accessible Production Drawing		SCALE	SHEET 1 OF 4
		1:2	REV B

LOC	DIST	REV	DATE	BY	CHK	APPV
A	66					

# FEED TYPE MECHANICAL

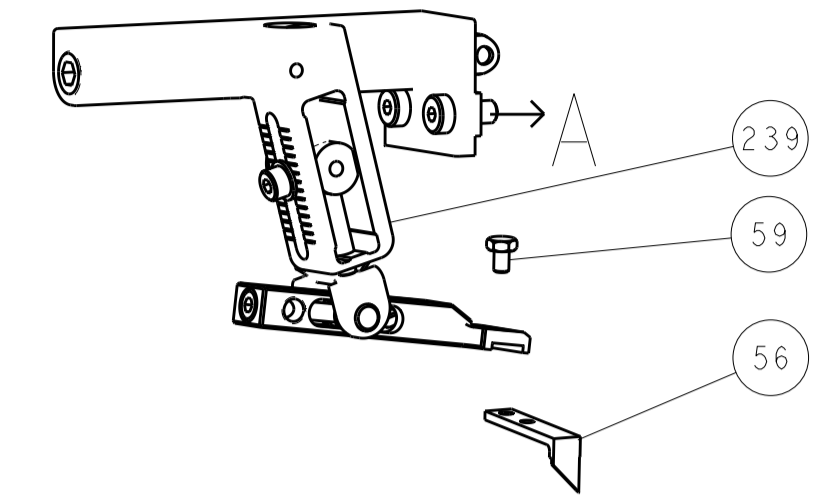

# PNEUMATIC

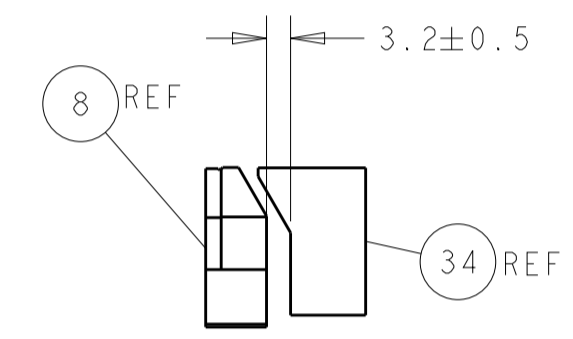
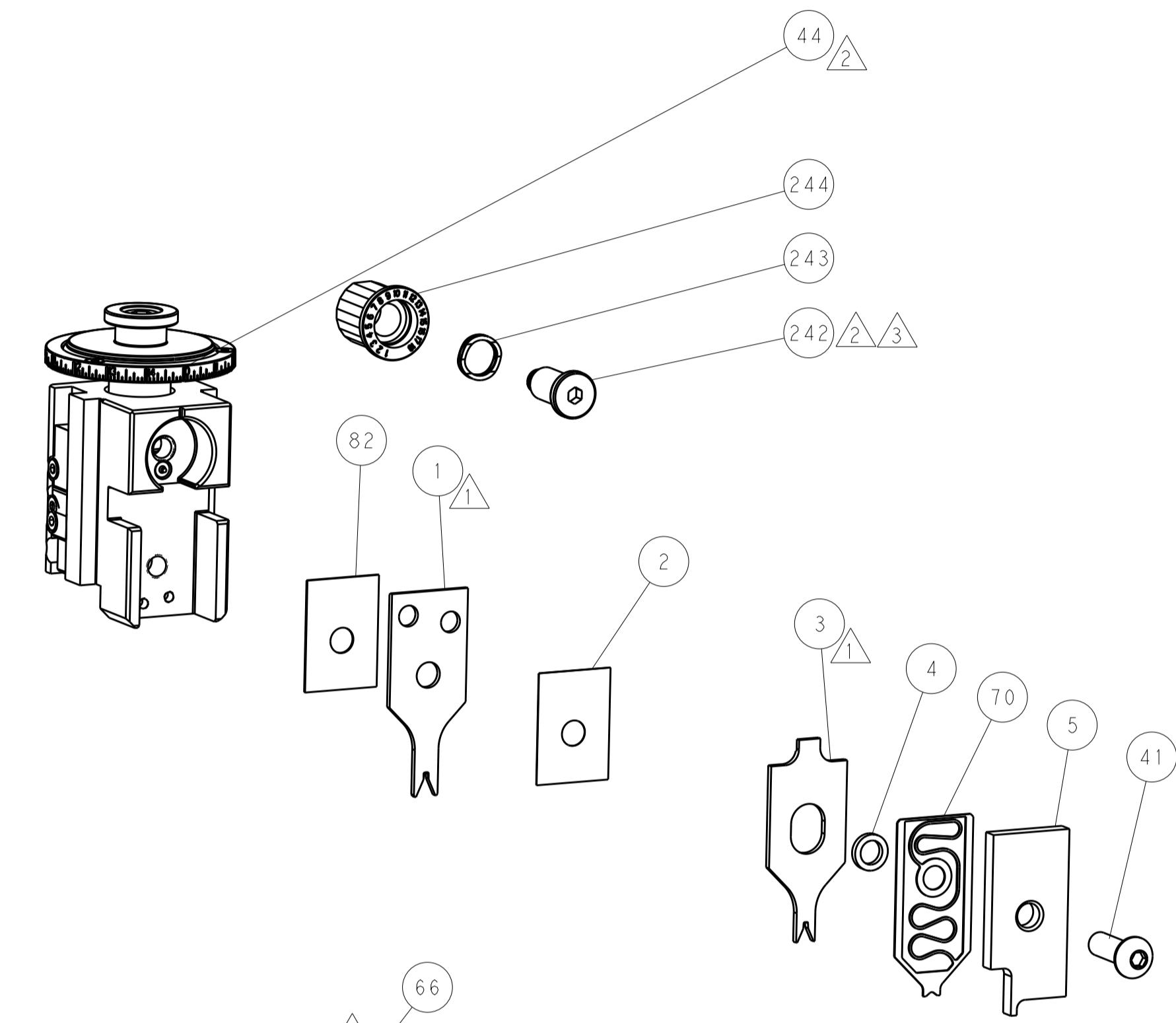
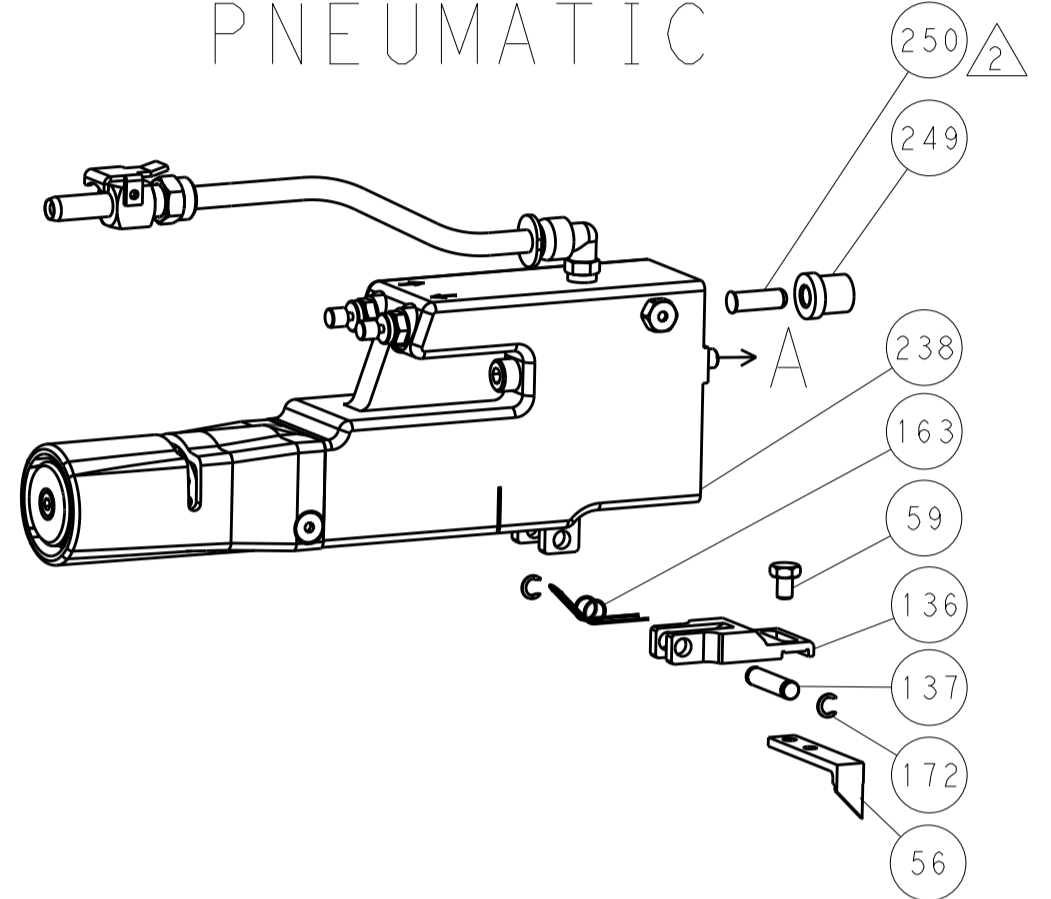

TERMINAL SUPPORT LOCATION

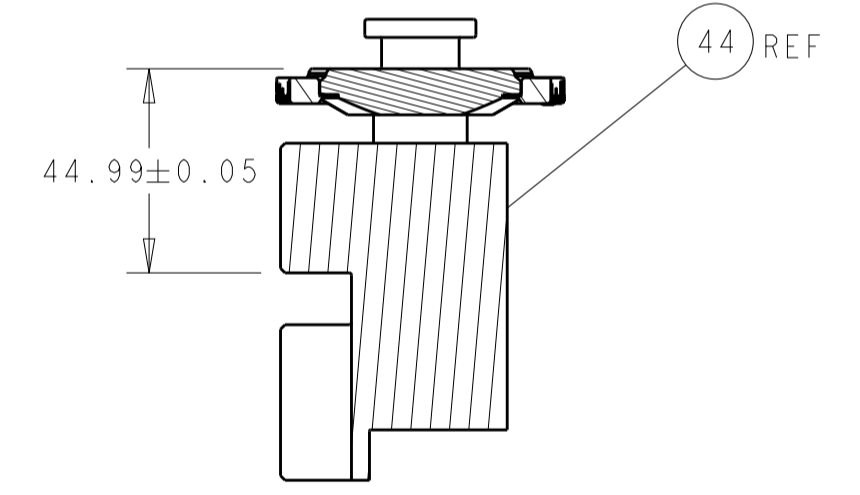

RAM SET-UP

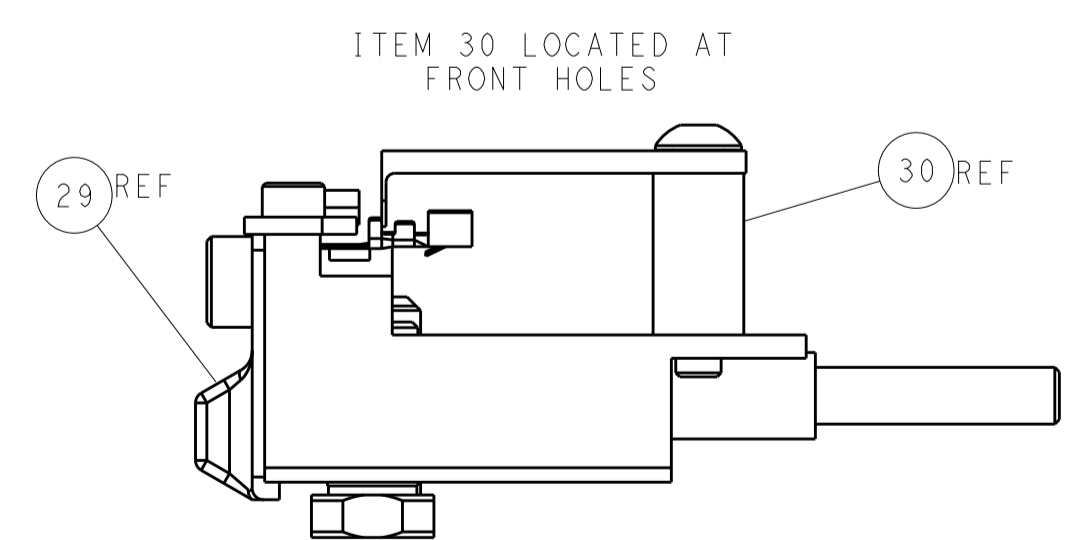
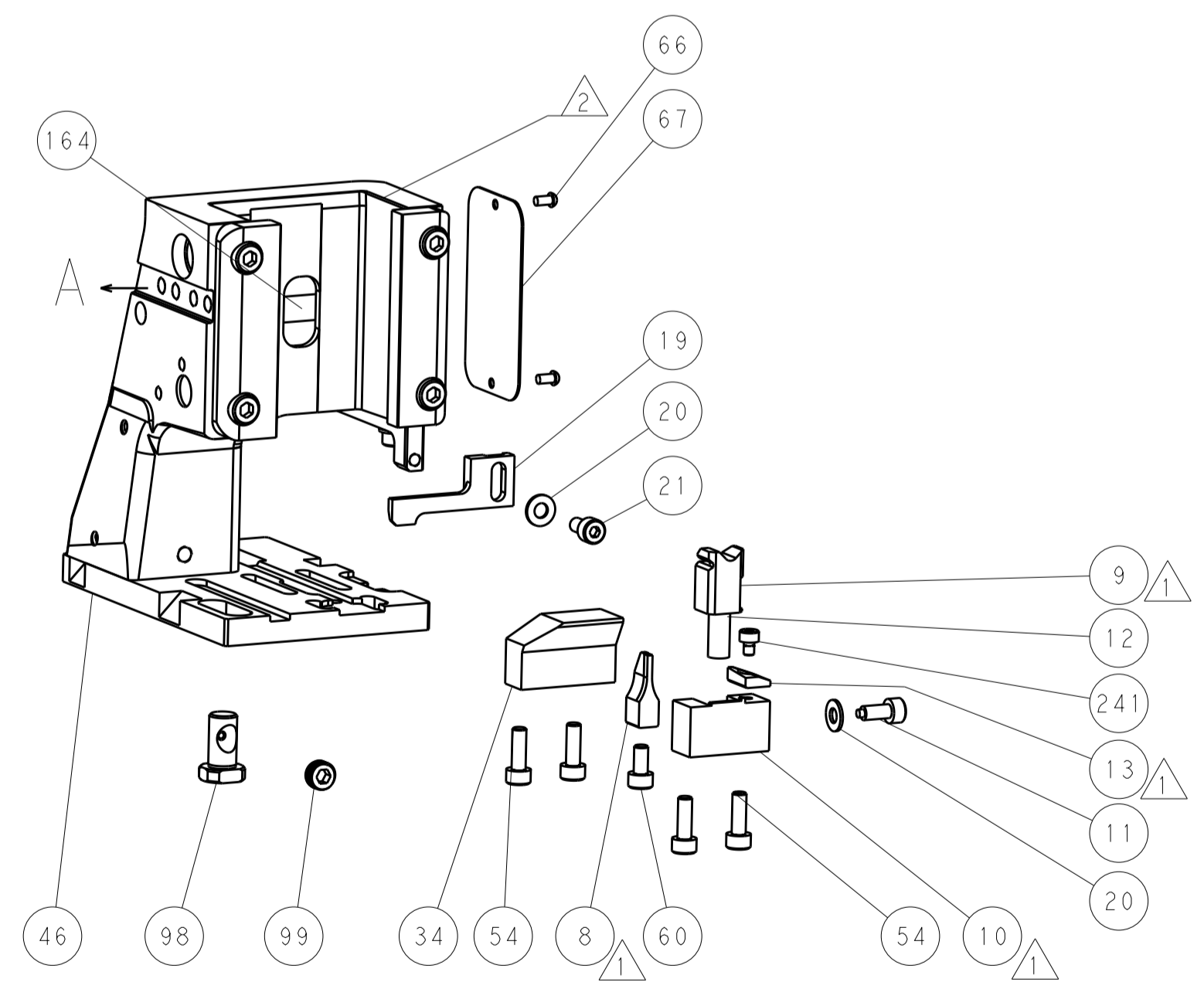
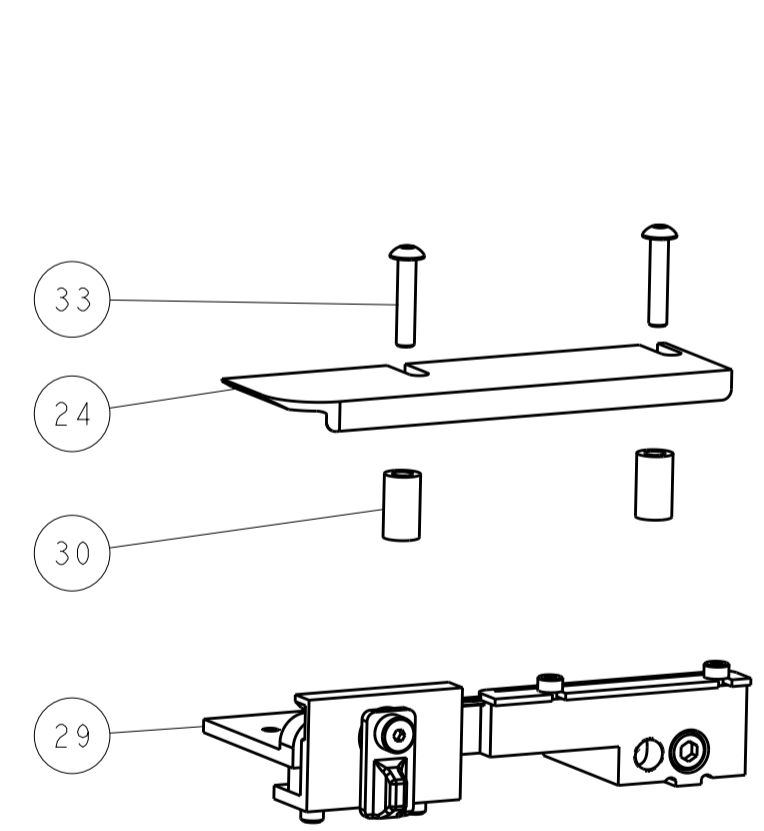

FEED TRACK POSITION  
GUIDE BY INSULATION BARREL

# CAM POSITIONS

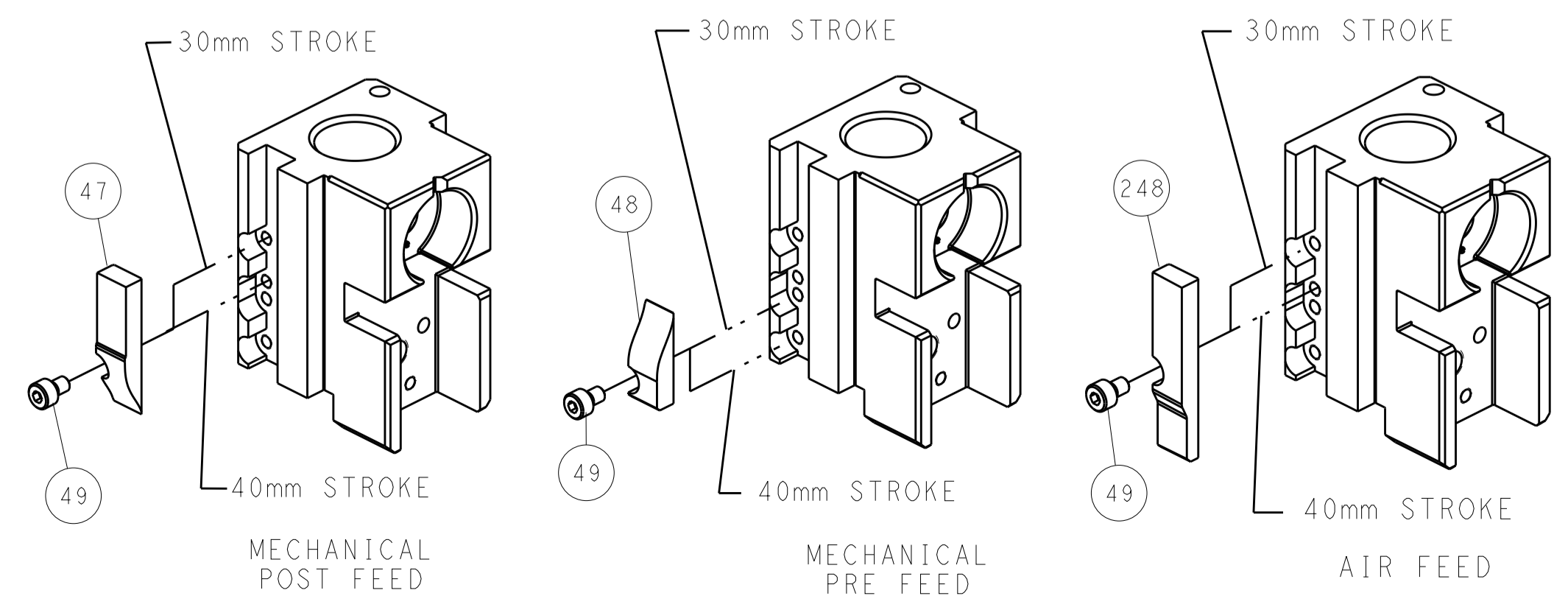

**ATLANTIC VERSION**  
 Shown on sheets 1 of 4 & 2 of 4  
 (Pacific version shown on sheets 3 of 4 & 4 of 4)

DIMENSIONS:		TOLERANCES UNLESS OTHERWISE SPECIFIED:		DWG: STAKEM 12JUNE2015		TE Connectivity	
mm	0 PLC ±	1 PLC ±	2 PLC ±	3 PLC ±	4 PLC ±	Harrisburg, PA 17105-3608	
MATERIAL:		FINISH:		APVD: T. ELBIN 12JUNE2015		NAME: Ocean Side Feed Applicator	
Customer Accessible Production Drawing		SCALE: 1:2		SHEET 2 OF 4		REV B	

PART NUMBER	REVISION	DESCRIPTION	FEED TYPE
2-2266814-1	B	FINE CRIMP HEIGHT ADJUST	MECHANICAL
2-2266814-2	B	FINE CRIMP HEIGHT ADJUST	PNEUMATIC
7-2266814-7	A	CRIMP TOOLING KIT	-

PACIFIC VERSION TERMINATOR  
 INTERFACE ADAPTER

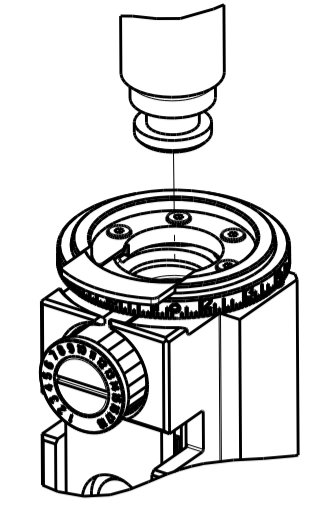

APPLICATOR DATA		
CRIMP	SIZE	TYPE
WIRE	1.47 mm [.058]	F
INSUL	1.65 mm [.065]	F

APPLICATOR INSTRUCTIONS  
 408-35042

TERMINAL DATA: JST TERMINAL		JST CRIMP SPECIFICATION	
TERMINAL NAME: TERMINAL			
WIRE STRIP LENGTH 2.30-3.10 mm [.091-.122 IN]		INSULATION DIAMETER RANGE Ø1.20-1.80 mm [.047-.071 IN]	
TERMINAL APPLICATION SPECIFICATION H4009/017-00 Rev 01-29-01			
TERMINALS APPLIED			
TE TERMINAL	JST TERMINAL	TE TERMINAL	JST TERMINAL
286860-1	SHF-001T-0.8BS	286860-4	SHF-001-0.8BS
286860-2	SHF-001T-0.8SS	286860-5	SHF-001G1-0.8BS
286860-3	SHF-001-0.8SS		

WIRE SIZE	CRIMP HEIGHT mm [INCH]	CRIMP HEIGHT REFERENCE SETTING
22 AWG	0.80 +/- 0.05 [.031 +/- .002]	5.1
24 AWG	0.75 +/- 0.05 [.030 +/- .002]	5.6
26 AWG	0.70 +/- 0.05 [.028 +/- .002]	6.2
28 AWG	0.68 +/- 0.025 [.027 +/- .001]	6.4



- 1 RECOMMENDED SPARE PARTS
- 2 REFER TO SUPPLIED INSTRUCTION SHEET FOR CLEANING, LUBRICATION AND STORAGE OF APPLICATOR.
- 3 APPLY PART NUMBER 2-23419-6 LOCTITE TO THREADS OF ITEM 242.
- 4 CRIMP HEIGHT REFERENCE SETTING WAS THE SETTING USED WHEN THE APPLICATOR WAS QUALIFIED AT THE FACTORY. ADJUSTMENT MAY BE NECESSARY WHEN RUNNING APPLICATOR IN THE FIELD.
- 5. UNLESS SPECIFIED OTHERWISE TORQUE VALUES SHALL BE USED PER DOCUMENT, 101-35000.

**\*WARNING**  
 ON INSTALLATION, SET WIRE DISC TO CRIMP HEIGHT REFERENCE SETTING FOR LARGEST WIRE SIZE. CRIMP HEIGHT REFERENCE SETTINGS GREATER THAN THE VALUE SHOWN MAY CAUSE DAMAGE TO THE CRIMP TOOLING, REFER TO THE INSTRUCTION SHEET FOR PROPER SETUP AND ADJUSTMENTS.

LOC	DIST	REV	DATE	BY	APPV
A	66				

REV	DATE	DESCRIPTION	DATE	BY	APPV
-	1	-	2119640-1	PUSH ROD, AIR FEED	250
-	1	-	1803259-1	BUSHING, FLANGED	249
-	1	1	2119082-4	CAM, SNAIL, INSULATION ADJUSTMENT	244
-	1	1	2079764-1	WASHER, WAVE SPRING, CREST-TO-CREST	243
-	1	1	2119083-1	RETAINER, INSULATION DIAL	242
-	1	1	7-18023-7	SCR, SKT HD CAP M3 X 4.0	241
-	-	1	2119580-1	MECHANICAL FEED ASSEMBLY	239
-	1	-	2063440-1	AIR FEED MODULE	238
-	2	-	21045-3	RING, RETAIN, EXTERN, 3/16 CRESCENT	172
-	REF	REF	994970-2	COUNTER, MAGNETIC	164
-	1	-	240638-1	SPRING, FEED FINGER	163
-	1	-	2119641-2	FEED CAM, AIR FEED	151
-	1	1	2168083-8	SCR, SKT HD CAP, RoHS, M4 X 16	144
-	4	4	2168083-9	SCR, SKT HD CAP, RoHS, M4 X 20	143
-	-	1	2119653-2	FEED CAM, POST FEED	142
-	1	1	1-1803583-0	APPLICATOR BASIC ASSEMBLY, SF	141
-	1	1	1803516-1	RAM ASSEMBLY, SF PACIFIC	140
-	1	-	3-23627-7	PIN, RETAIN, GRVD, 3/16 X .854	137
-	1	-	2119799-1	HOLDER, FEED FINGER, AF	136
-	1	1	2844908-1	SCREW, LOCKING	99
-	1	1	2844907-1	POST, LOCKING	98
-	1	1	455888-5	SPACER, CRIMPER	82
-	1	1	1803607-1	DOCUMENTATION PACKAGE	71
-	1	1	2119791-5	DEPRESSOR, WIRE	70
-	1	1	2119740-1	TAG, IDENTIFICATION	67
-	2	2	2168078-1	SCREW, DRIVE, RH, RoHS, 2 x .188	66
-	1	1	5-18022-5	SCR, HEX HD CAP, M4 X 6.0	59
-	1	1	1338685-1	PAWL, FEED	56
-	1	2	18023-9	SCR, SKT HD CAP M4 X 6.0	49
-	-	1	2119652-1	FEED CAM, PRE FEED	48
-	1	1	1803602-1	SCR, BHSC, RoHS (M8 X 25)	41
-	1	1	2-1752356-5	SUPPORT, TERMINAL	34
-	2	2	2079383-5	SCR, BHSC, RoHS (M4 X 20)	33
-	2	2	2-2844962-6	SPACER, CYLINDRICAL, STRIP GUIDE	30
-	1	1	2844992-1	ASSEMBLY, STRIP GUIDE	29
-	1	1	1320928-2	STRIP GUIDE	24
-	1	1	2168083-2	SCR, SKT HD CAP, RoHS, M4 X 8.0	21
-	2	2	1-18028-2	WASHER, FLAT, REG M4	20
-	1	1	2119533-1	STRIPPER, SIDE FEED	19
-	1	1	2119806-1	INSERT, SHEAR	13
-	1	1	3-22280-3	SPRING, COMPRESSION	12
-	1	1	1-356885-4	STOP, SHEAR	11
-	1	1	2119805-1	SHEAR HOLDER, FRONT	10
-	1	1	1803095-3	FLOATING SHEAR, FRONT	9
1	1	1	5-1803171-0	ANVIL, COMBINATION	8
-	-	-	-	-	7
-	-	-	-	-	6
-	1	1	2119757-5	DEPRESSOR, SHEAR	5
-	1	1	238011-8	BLOCK, CRIMPER SPACER	4
1	1	1	9-1633962-5	CRIMPER, INSULATION F PREMIUM	3
-	1	1	455888-1	SPACER, CRIMPER	2
1	1	1	8-1633730-3	CRIMPER, WIRE	1

DIMENSIONS: mm		TOLERANCES UNLESS OTHERWISE SPECIFIED:		DWG: STAKEM 12JUNE2015		CHK: G. BAILEY 12JUNE2015		APVD: T. ELBIN 12JUNE2015		NAME: Ocean Side Feed Applicator	
0 PLC ±		1 PLC ±		2 PLC ±		3 PLC ±		4 PLC ±		RESTRICTED TO	
MATERIAL: -		FINISH: -		WEIGHT: -		SCALE: 1:2		SHEET: 3 OF 4		REV: B	

PACIFIC VERSION  
 Shown on sheets 3 of 4 & 4 of 4  
 (Atlantic version shown on sheets 1 of 4 & 2 of 4)

LOC	DIST	REVISIONS					
		P	LTN	DESCRIPTION	DATE	DMN	APVD
A	66	-	-	SEE SHEET 1	-	-	-

# FEED TYPE MECHANICAL

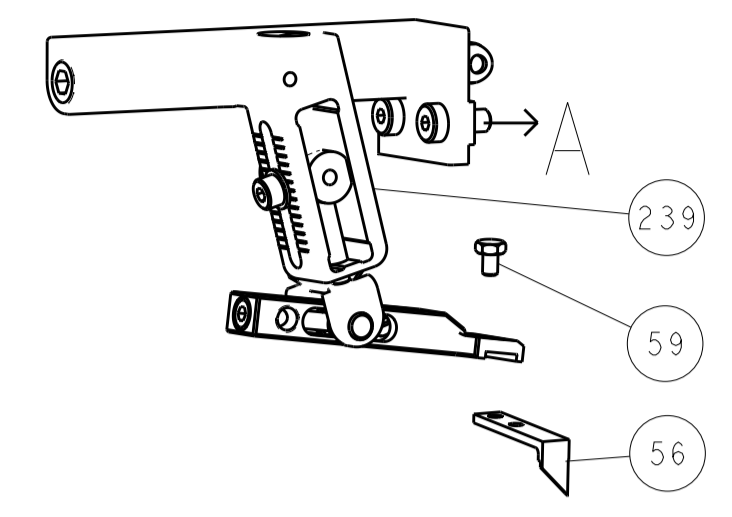

# PNEUMATIC

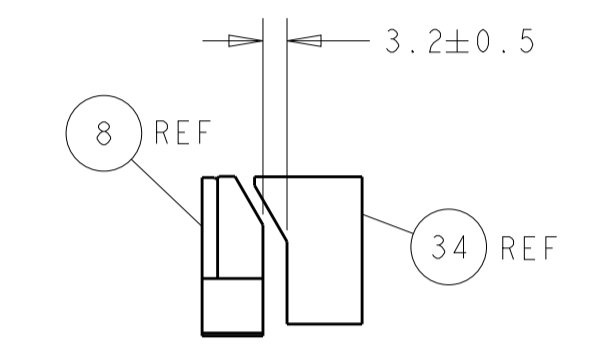
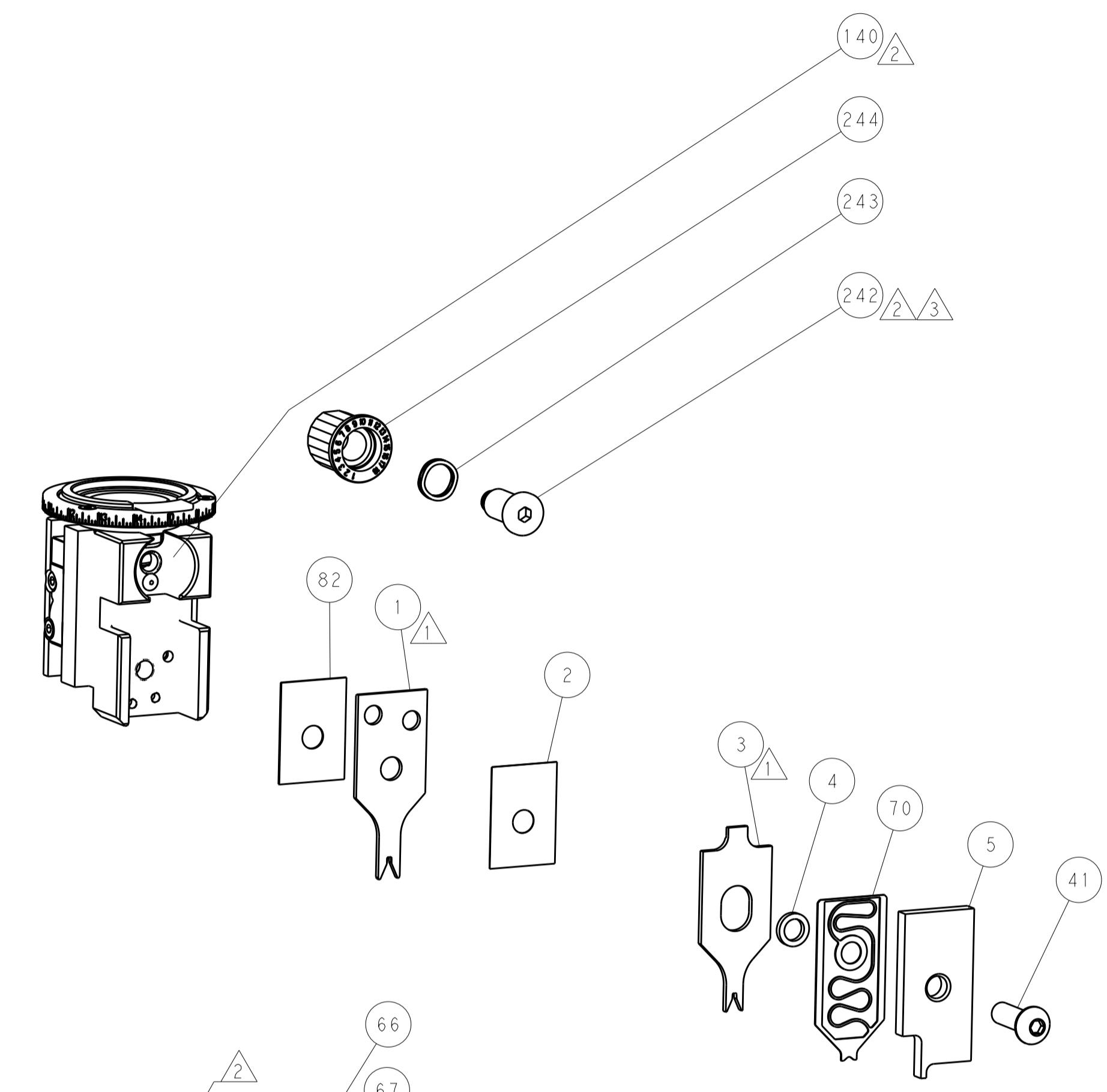
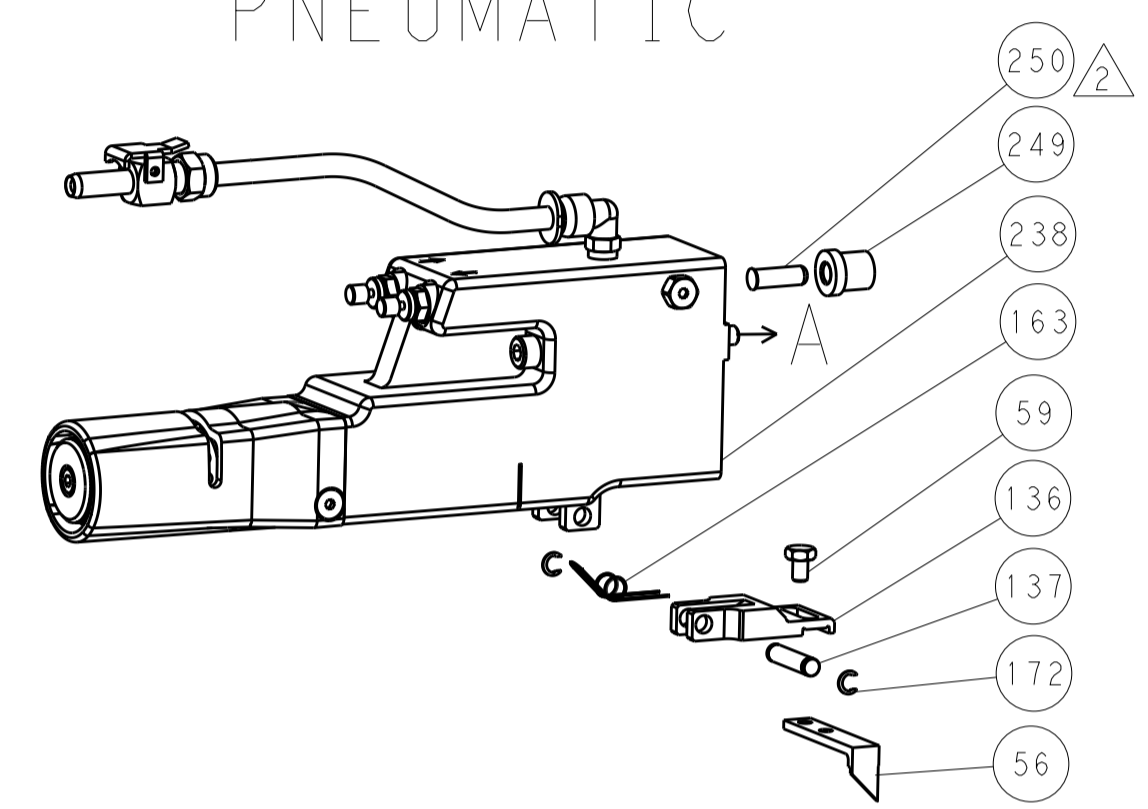

TERMINAL SUPPORT LOCATION

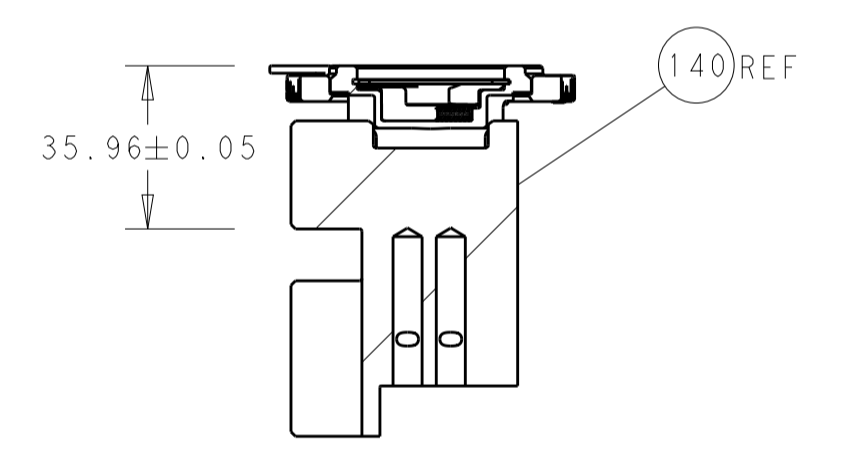

RAM SET-UP

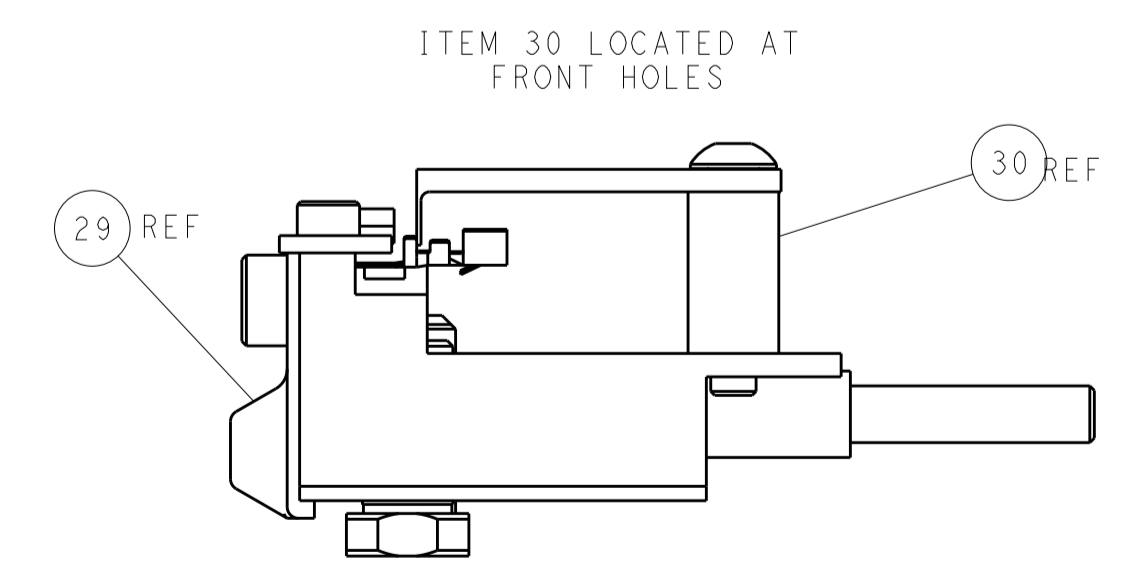

FEED TRACK POSITION  
GUIDE BY INSULATION BARREL

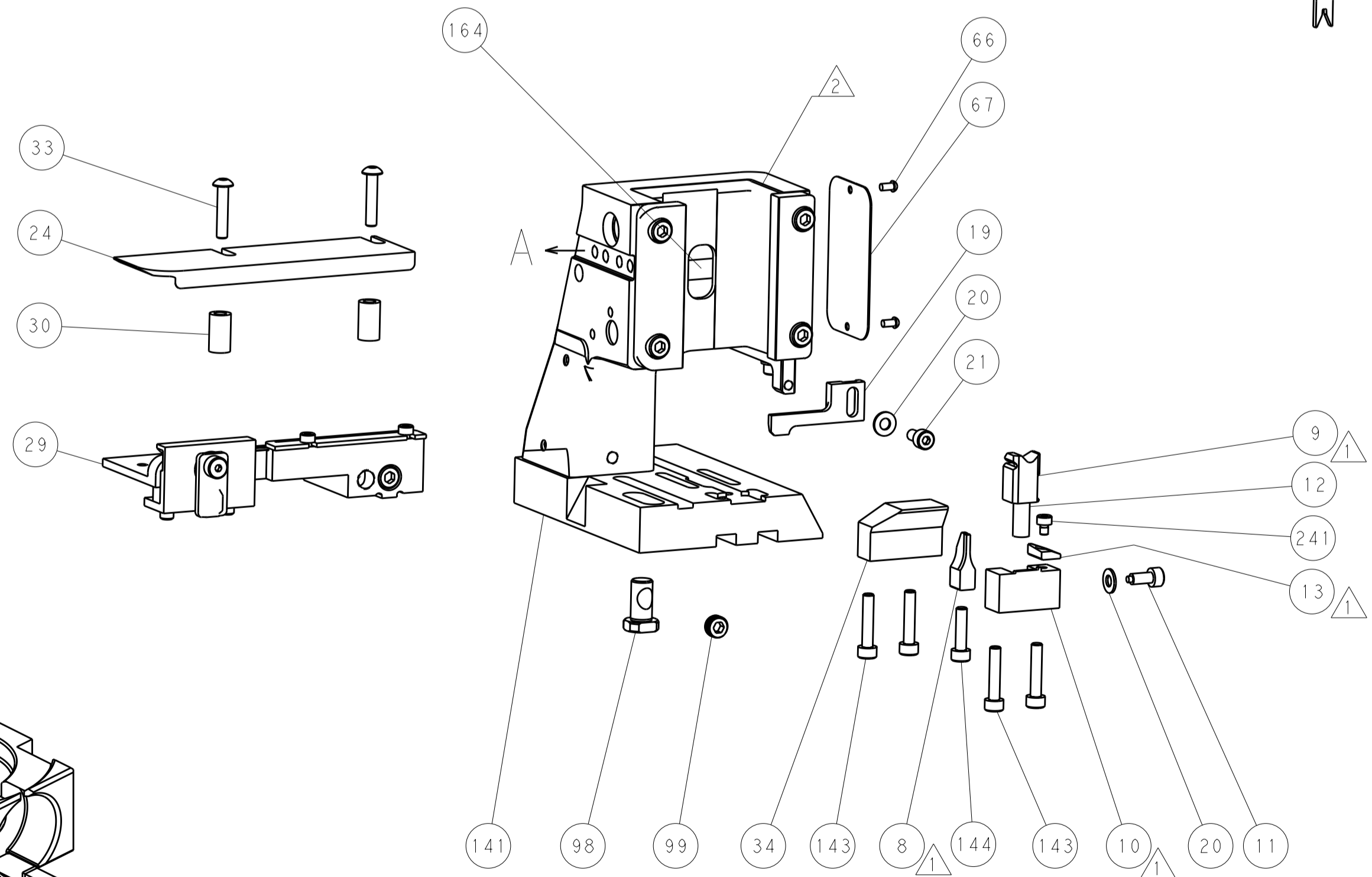

# CAM POSITIONS

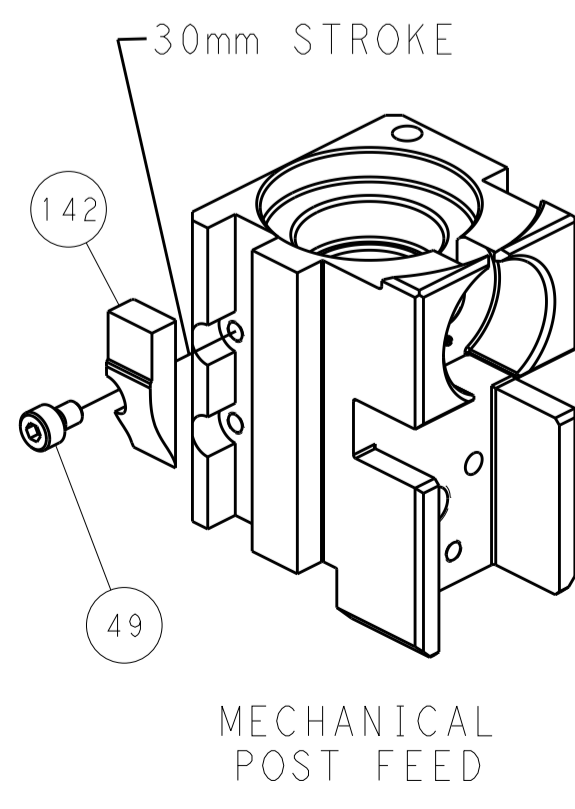

MECHANICAL  
POST FEED

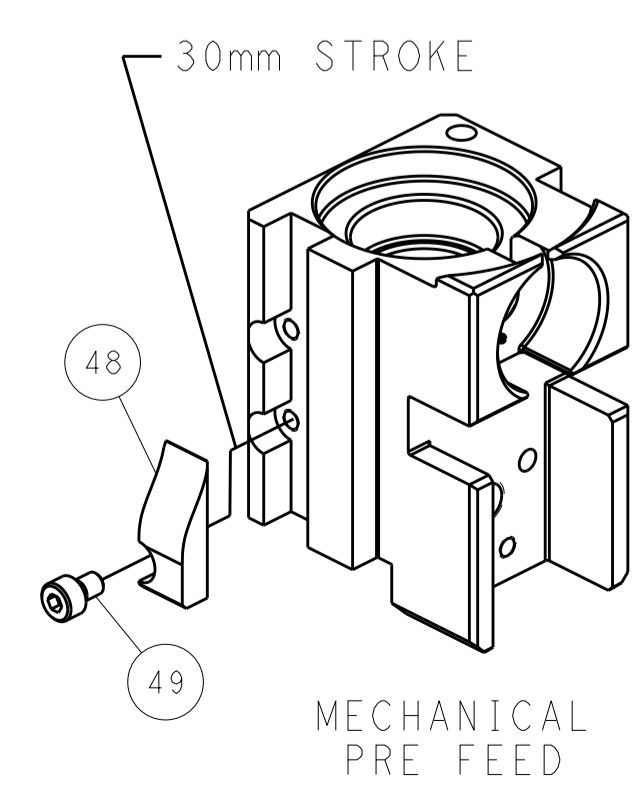

MECHANICAL  
PRE FEED

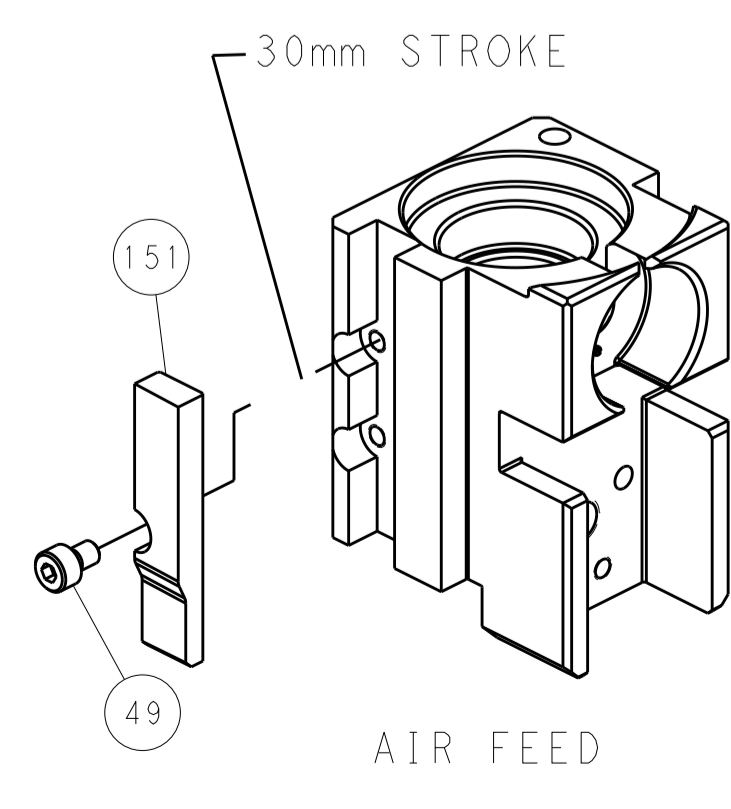

AIR FEED

**PACIFIC VERSION**  
 Shown on sheets 3 of 4 & 4 of 4  
 (Atlantic version shown on sheets 1 of 4 & 2 of 4)

DIMENSIONS:		TOLERANCES UNLESS OTHERWISE SPECIFIED:		DWG: STAKEM 12JUNE2015		TE Connectivity	
mm	0 PLC ±	1 PLC ±	2 PLC ±	3 PLC ±	4 PLC ±	5 PLC ±	Harrisburg, PA 17105-3608
MATERIAL:		FINISH:		CHK: G. BAILEY 12JUNE2015		NAME: Ocean Side Feed Applicator	
APVD: T. ELBIN 12JUNE2015		PRODUCT SPEC:		APPLCATION SPEC:		SIZE: CAGE CODE: DRAWING NO: RESTRICTED TO	
Customer Accessible Production Drawing		SCALE: 1:2		SHEET 4 OF 4		REV B	