

THIS DRAWING IS UNPUBLISHED. RELEASED FOR PUBLICATION
 © COPYRIGHT BY TYCO ELECTRONICS CORPORATION. ALL RIGHTS RESERVED.

LOC		DIST		REVISIONS			
P	LTR	DESCRIPTION	DATE	DWN	APVD		
	A	REDRAWN IN AUTOCAD	04-08-08	BDW	BKW		

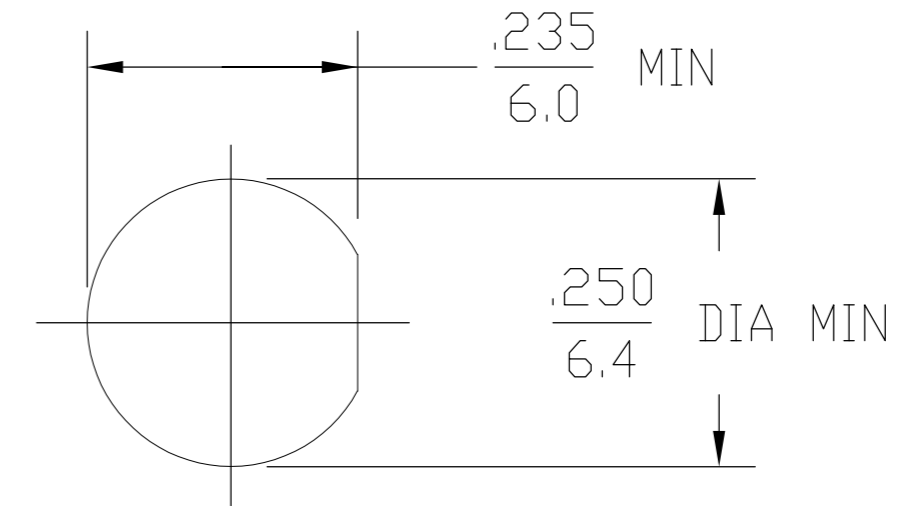
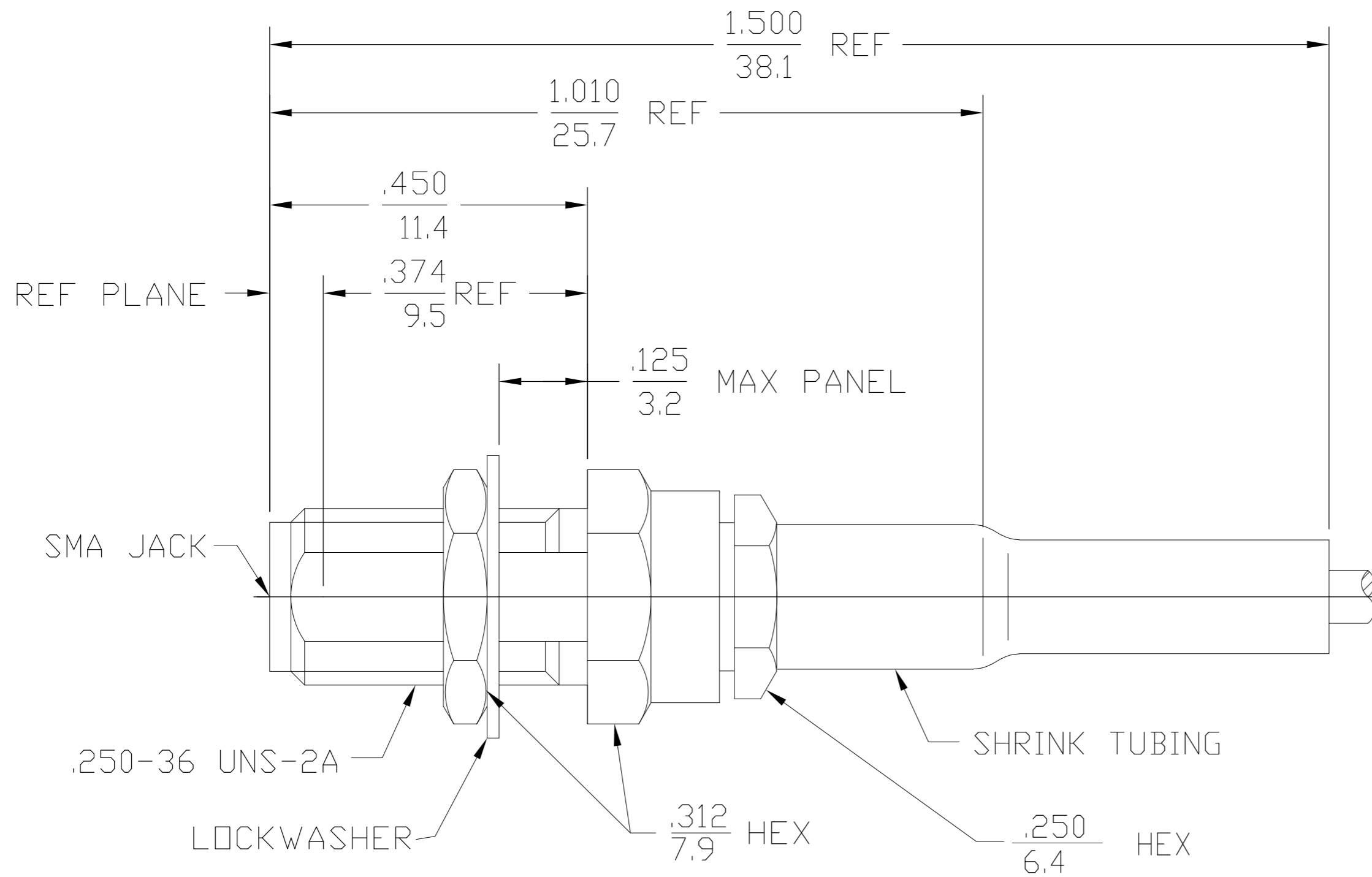

RECOMMENDED MOUNTING HOLE

NOTES:
 1. SEE INSTRUCTION SHEET 408-4802 FOR CABLE TERMINATION DETAILS.

DESIGNED FOR USE WITH RG178/U & SIMILAR CABLES CABLE ENTRY DIAMETER MINIMUM	
CONTACT	.021
SLEEVE	.036
FERRULE	.098

COMPONENT	MATERIAL	FINISH
HOUSING MOUNTING NUT CLAMP NUT SLEEVE	STAINLESS STEEL	PASSIVATED
DIELECTRIC	PTFE	N/A
CENTER CONTACT	COPPER ALLOY	GOLD PLATED
LOCKWASHER	PHOSPHOR BRONZE	NICKEL PLATED
O-RING	SILICONE RUBBER	N/A
SHRINK TUBING	HEAT SHRINKABLE POLYOLEFIN COMPOUND	N/A
FERRULE	COPPER OR BRASS ALLOY	GOLD PLATED

ELECTRICAL	MECHANICAL	ENVIRONMENTAL
Nominal Impedance (Ohms) 50	Interface Dimensions MIL-STD-348A, Fig. 310.2	TEMPERATURE RATING -65°C TO +165°C
Frequency Range (GHz) DC to 12.4	Recommended Mating Torque N/A	Vibration MIL-STD-202, Method 204, Condition D
Volt Rating (VRMS MAX) @ Sea Level 170	Mating Characteristics:	Shock MIL-STD-202, Method 213, Condition I
VSWR 1.20 + [0.02 f(GHz)]	Insertion (MAX Lbs) 3.0	Thermal Shock MIL-STD-202, Method 107, Condition B
Insertion Loss (dB MAX) .06 √ f(GHz)	Withdrawal (MIN Oz) 1.0	EXCEPT HIGH TEMP SHALL BE +85°C
RF Leakage (dB MIN) -60 @ 2-3 GHz	Force to Engage and Disengage (In/Lbs MAX) 2.0	Moisture Resistance MIL-STD-202, Method 106, Except Vibration
Corona, 70,000 Ft (VRMS MIN) 125	Center Contact Captivation	Shall Be Omitted
Dielectric Withstanding Voltage (VRMS MIN) @ Sea Level 500	Axial (Lbs) 6.0	Corrosion - MIL-STD-202, Method 101, Condition B, 5% salt spray
Contact Resistance (Milliohms MAX) Center Contact 2.0	Radial (In/Oz) N/A	
Outer Contact 2.0	Cable Retention	
Cable to Housing 0.5	Axial Force (Lbs) 10.0	
RF High Potential @ Sea Level (VRMS MIN @ 5 MHz) 335	Torque (In/Oz) N/A	
I.R.(Megohms MIN) 10,000	Weight (Grams) 4.2	

.XXX = in
 XX.X = mm

THIS DRAWING IS A CONTROLLED DOCUMENT.

DWN BDW 31MAY1988	Tyco Electronics Corporation Harrisburg, PA 17105-3608	
CHK MY 02JUN1988		
APVD PH 08JUN1988		
NAME		
DIMENSIONS: INCHES	PRODUCT SPEC	SMA BULKHEAD FEEDTHROUGH PASSIVATED CABLE JACK FOR RG 178/U CABLE CRIMP ATTACH (2034-5031-02)
TOLERANCES UNLESS OTHERWISE SPECIFIED:	APPLICATION SPEC	
0 PLC ± -	SIZE	A2
1 PLC ± -	CAGE CODE	00779
2 PLC ± -	DRAWING NO	C=1051951
3 PLC ± .005	RESTRICTED TO	
4 PLC ± -	WEIGHT	
ANGLES ± 1	CUSTOMER DRAWING	SCALE 1:1 SHEET 1 of 1 REV A
MATERIAL	FINISH	