

THIS DRAWING IS UNPUBLISHED. RELEASED FOR PUBLICATION ,19

© COPYRIGHT 19 BY AMP INCORPORATED. ALL INTERNATIONAL RIGHTS RESERVED.

| LOC  | DIST | P           | F    | REVISIONS |                      |         |       |
|------|------|-------------|------|-----------|----------------------|---------|-------|
| ZONE | LTR  | DESCRIPTION | DATE | APPD      |                      |         |       |
| AF   | 50   |             |      | H         | REV PER 0G3A-0677-02 | 12NOV02 | JR/ND |

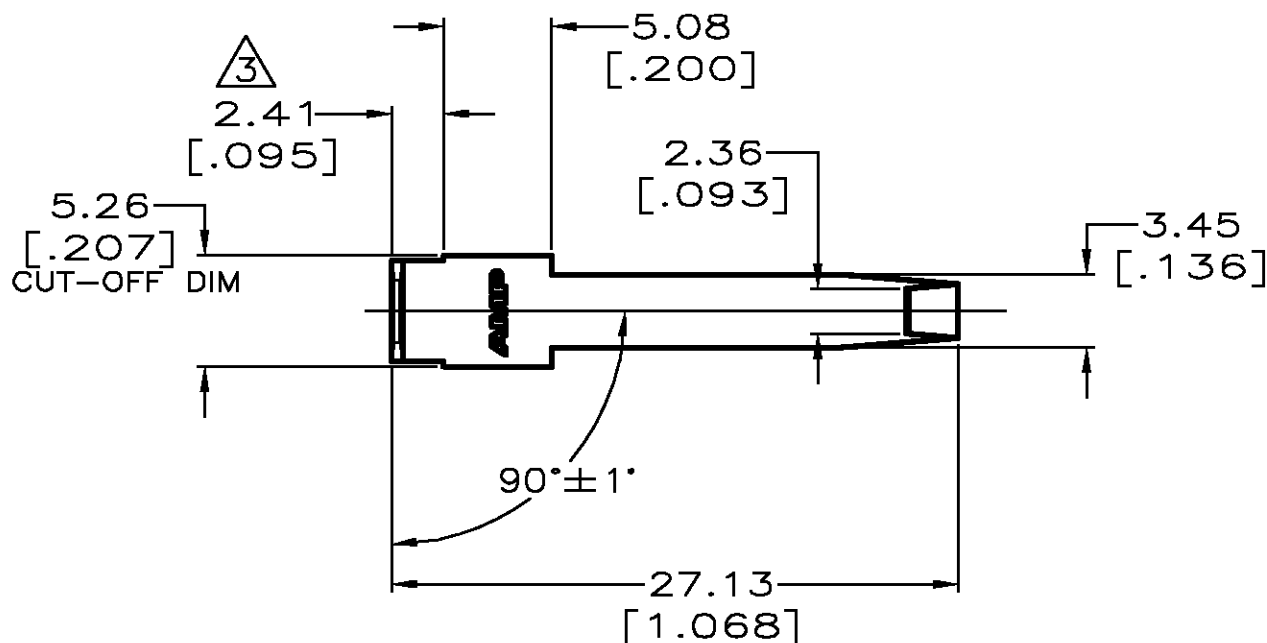

- 1 SUPPLIED IN LOOSE PIECE
- 2 0.41 [.016] THK 1/4 HARD S.STEEL WITH 0.102 [.004] THK COPPER CLAD, THIS SIDE ONLY.
- 3 DIM APPLIES AT TANGENT OF RADIUS AT BASE.
- 4 CLEANING PROCESS NOT INCLUDED.
- 5 0.51 [.020] THK 1/4 HARD S.STEEL
- 6 PRELIMINARY - NOT FOR PRODUCTION.

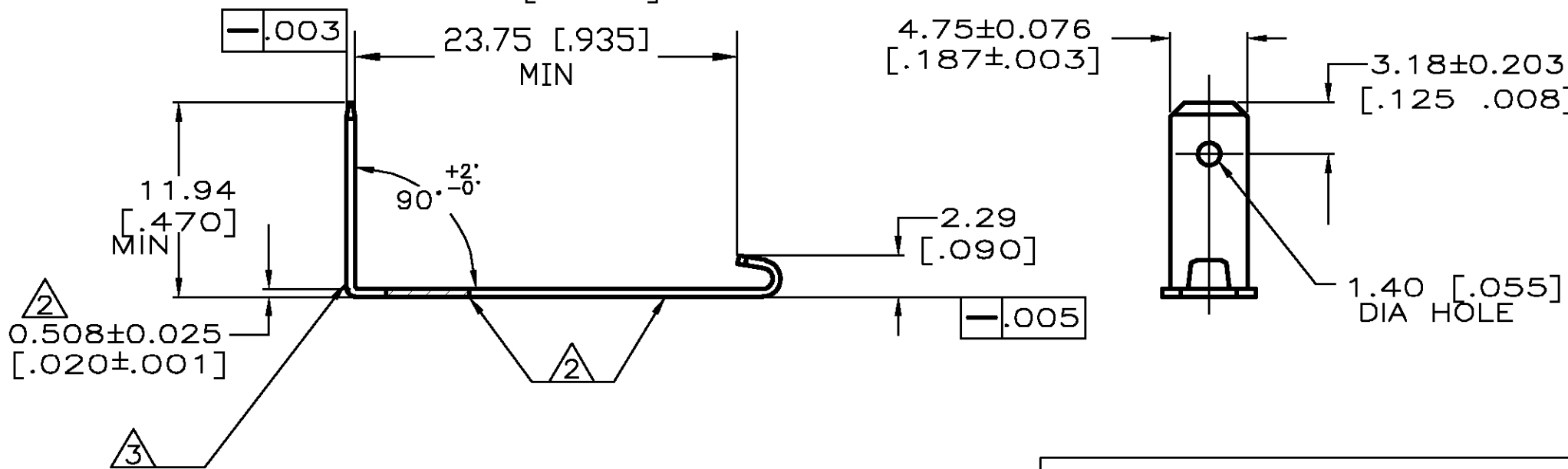

| FINISH | MATERIAL  | PART NO   |
|--------|-----------|-----------|
| -      | 5 63953-3 | 6 63953-3 |
| 4      | 2 63953-2 | 6 63953-2 |
| -      | 2 63953-1 |           |

|                                      |                          |
|--------------------------------------|--------------------------|
| DO NOT SCALE PRINT. UNLESS SPECIFIED | DR 11/14/97 JR RUTH      |
| DIMENSIONS IN mm [INCHES]            | CHK 11/14/97 MS FEHER    |
| TOLERANCES ON:                       | APPD 11/14/97 P DESANTIS |
| 2 PLC DEC ± 0.25 [.010]              | APPD 11/14/97 D BRATINA  |
| 3 PLC DEC ± -                        | PRODUCT SPEC -           |
| ANGLES ± 1'                          | APPLICATION SPEC -       |
| MATERIAL SEE TABLE                   | WEIGHT -                 |
| FINISH SEE TABLE                     |                          |

|  |                    |                       |
|--|--------------------|-----------------------|
| <b>AMP</b> AMP Incorporated<br>Harrisburg, PA 17105-3608 |                    |                       |
| NAME<br>TAB, SPECIAL, 4.75 [.187] SERIES                 |                    |                       |
| SIZE<br>B  | CAGE CODE<br>00779 | DRAWING NO<br>C=63953 |
| SCALE<br>3:1   | SHEET<br>1 OF 1    |                       |

THIS DRAWING IS A CONTROLLED DOCUMENT FOR AMP INCORPORATED. IT IS SUBJECT TO CHANGE AND THE CONTROLLING ENGINEERING ORGANIZATION SHOULD BE CONTACTED FOR THE LATEST REVISION.