

REVISIONS			
REV	DESCRIPTION, ECN, EAR NO.	DATE	APP'D
A	PROPOSAL DRAWING (EAR 15047)	NOV26/21	K.L.

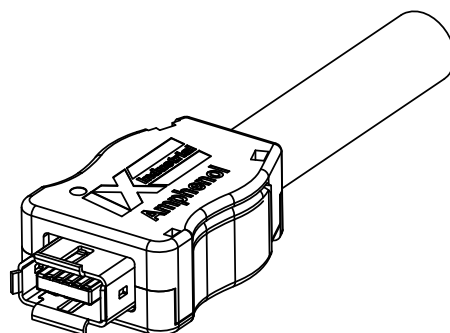
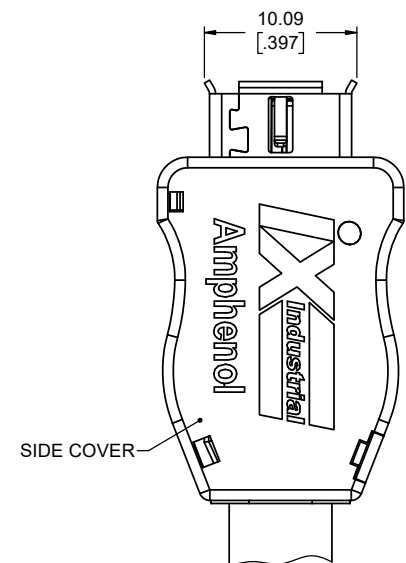

ORDERING CODE: ND9 - ACKX - XXA

- SERIES, IX INDUSTRIAL ETHERNET
- TYPE A KEY FOR ETHERNET
- CABLE ASSEMBLY
- RECEPTACLE ONE END WITH CABLE PIGTAIL OTHER END
- PLATING FOR MATING AREA
2 = 0.20µm (8µ") GOLD
4 = 1.27µm (50µ") GOLD
- 8 WIRE CABLE

CABLE LENGTHS (DIMENSION 'A')	
	LENGTH IN CM
20 TO 99	
A0 TO A9	1 METER + 0 TO 9 DECIMETERS
B0 TO B9	2 METERS + 0 TO 9 DECIMETERS
C0 TO C9	3 METERS + 0 TO 9 DECIMETERS
D0 TO D9	4 METERS + 0 TO 9 DECIMETERS
E0 TO E9	5 METERS + 0 TO 9 DECIMETERS
F0 TO F9	6 METERS + 0 TO 9 DECIMETERS
G0 TO G9	7 METERS + 0 TO 9 DECIMETERS
H0 TO H9	8 METERS + 0 TO 9 DECIMETERS
J0 TO J9	9 METERS + 0 TO 9 DECIMETERS
K0 TO K9	10 METERS + 0 TO 9 METERS
L0 TO L9	20 METERS + 0 TO 9 METERS
M0 TO M9	30 METERS + 0 TO 9 DECAMETERS

CABLE LENGTH ORDERING CODE EXAMPLES:
75cm = 75 6.3m = F3 25m = L5 80m = M5

NOTES:

- MATERIAL: RoHS COMPLIANT PER EU DIRECTIVE 2011/65/EU AND AMENDMENTS.
 - SHIELDS: STAINLESS STEEL, NICKEL PLATED
 - INSERTS: GLASS REINFORCED ENGINEERING THERMOPLASTIC, UL 94V-0, BLACK
 - SIDE COVERS: POLYCARBONATE UL 94V-0, COVER BLACK
 - CONTACTS: COPPER ALLOY WITH MATING AREA PLATING PER ORDERING CODE OVER 1.27µm (50µ") MINIMUM NICKEL.
 - CABLE: COPPER CONDUCTOR 26 AWG, 7 STRANDS, PE INSULATION DIA 0.95 TO 1.05mm (.037 TO .041"), METAL FOIL WRAPPED TWISTED PAIRS, OVERALL TIN PLATED BRAID, PVC JACKET DIA 6.3 TO 7.2mm (.244 TO .283")
- DESIGNED TO CONFORM TO REQUIREMENTS OF IEC 61076 PART 3-124 SPECIFICATION. THE TYPE A KEY FEATURE SHOWN IS INTENDED FOR USE WITH ETHERNET APPLICATIONS, EITHER 10/100 MBIT/S OR 1 TO 10 GBIT/S (CAT 5e, 6 & 6A).
- CURRENT RATING: 1.5 AMPERES, VOLTAGE RATING: 50V AC rms OR 60V DC
- OPERATING TEMPERATURE -40° TO +80°C.
- DIELECTRIC WITHSTANDING VOLTAGE: 500V DC
- INSULATION RESISTANCE: 500 MEGOHMS MINIMUM.
- MATING & UNMATING FORCE: 25N (5.6 lbf) MAXIMUM
- CUSTOMER TO CONFIRM THAT ANY PROCESS CLEANERS USED NEAR THE SIDE COVERS TO BE POLYCARBONATE COMPATIBLE.

CONNECTOR PIN ASSIGNMENT			
POSITION NUMBER	PIN ASSIGNMENT 10 OR 100 MBIT/S ETHERNET	PIN ASSIGNMENT 1, 2, 5 OR 10 GBIT/S ETHERNET	WIRE COLOUR (TIA/EIA 568-B)
1	TX +	BI_DA +	WHITE/ORANGE
2	TX -	BI_DA -	ORANGE
3	NOT USED	-	-
4	NOT USED	BI_DC +	BLUE
5	NOT USED	BI_DC -	WHITE/BLUE
6	RX +	BI_DB +	WHITE/GREEN
7	RX -	BI_DB -	GREEN
8	NOT USED	-	-
9	NOT USED	BI_DD +	WHITE/BROWN
10	NOT USED	BI_DD -	BROWN

NOTE:
CONTACTS #3 & #8 ARE CONNECTED TO THE SHIELD / CABLE BRAID. TWISTED PAIRS FOR POSITIONS 1/2, 4/5, 6/7 & 9/10.

THIS DOCUMENT CONTAINS PROPRIETARY INFORMATION AND SUCH INFORMATION MAY NOT BE DISCLOSED TO OTHERS FOR ANY PURPOSE OR USED FOR MANUFACTURING PURPOSES WITHOUT WRITTEN PERMISSION FROM AMPHENOL CANADA CORP.

UNLESS SPECIFIED OTHERWISE	DRAWN	B.COPPING	NOV26/21
PRIMARY UNITS MILLIMETERS	CHECKED	K.LAMBIE	NOV26/21
SECONDARY UNITS INCHES	M.E. APP'D		
REFERENCE IN PARENTHESES	Q.A. APP'D		
GENERAL TOLERANCES	DWG APPR.		
1 DECIMAL PLACE	ENG. REL. NO.	EAR 15047	
2 DECIMAL PLACES	REF.		
3 DECIMAL PLACES	THIRD ANGLE PROJECTION		
ANGULAR DEGREES	DO NOT SCALE DRAWING		

Amphenol Canada Corp.
Commercial Products

IX INDUSTRIAL ETHERNET, CABLE ASSEMBLY TYPE A, RECEPTACLE WITH CABLE PIGTAIL, VARIOUS LENGTHS, RoHS COMPLIANT

DWG. NO. **P-ND9-ACKX-XXA** REV **A**

CODE ID NO. 03554 DWG SIZE: X SCALE: 4:1 SHEET 1 OF 1