

# Infrared Light Emitting VCSEL

## OPR2800V



### Features:

- High speed VCSEL
- High output power
- Narrow beam angle
- Suitable for all types of high-speed data communications equipment
- Also available as diode (OPR2800, OPR2800T)

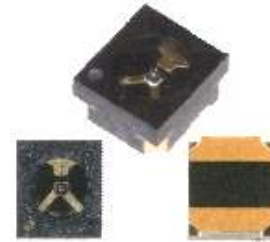

### Description:

The OPR2800V is a high performance 850 nm invisible VCSEL (Class 1M) with a flat lens window. Its high speed, high output power and concentric beam pattern make it an ideal transmitter for all types of high-speed data equipment applications.

Please refer to Application Bulletins 221 and 224 for additional design information and reliability (degradation) data.

Refer to Application Bulletin 237

### Applications:

- Fibre channel
- Gigabit Ethernet
- ATM
- VSR (Very Short Reach)
- Intra-system links
- Optical backplane terconnects

Ordering Information				
Part Number	LED Peak Wavelength	Total Beam Angle	Laser Class	Packaging
OPR2800V	850 nm	24°	<b>Class 1M</b>	Chip Tray

### OPR2800V

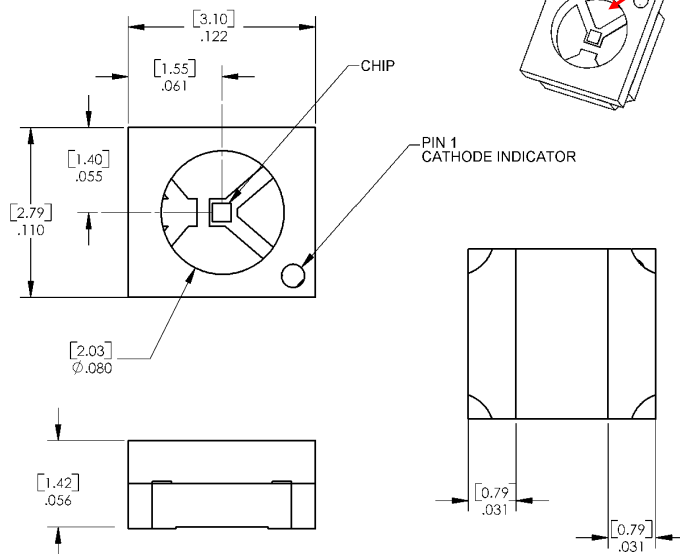

**Warning:** Front Window is pressure sensitive. Do not apply pressure or high vacuum to window.

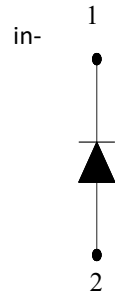

Pin #	LED
1	Cathode
2	Anode



### General Note

TT Electronics reserves the right to make changes in product specification without notice or liability. All information is subject to TT Electronics' own data and is considered accurate at time of going to print.

TT Electronics | Optek Technology, Inc.  
1645 Wallace Drive, Ste. 130, Carrollton, TX USA 75006 | Ph: +1 972 323 2200  
www.ttelectronics.com | sensors@ttelectronics.com

### Electrical Specifications

#### Absolute Maximum Ratings ( $T_A = 25^\circ\text{C}$ unless otherwise noted)

Storage Temperature Range	-40° C to +100° C
Operating Temperature Range	0° C to +85° C
Maximum Forward Peak Current	20 mA
Maximum Reverse Voltage	10 V
Maximum Continuous Optical Power at 70° C	1.1 mW
Solder reflow time within 5° C of peak temperature is 20 to 40 seconds	250° C <sup>(1)</sup>

Notes:

1. Solder time less than 5 seconds at temperature extreme.

#### Electrical Characteristics ( $T_A = 25^\circ\text{C}$ unless otherwise noted)

SYMBOL	PARAMETER	MIN	TYP	MAX	UNITS	TEST CONDITIONS
$V_F$	Forward Voltage	1.60	-	2.20	V	$I_F = 7\text{ mA}$
$I_R$	Reverse Current	-	-	35	$\mu\text{A}$	-
$t_r, t_f$	Output Rise Time, Output Fall Time	-	100	-	ps	20% to 80%
$P_{OT}$	Total Power Out	1.50	-	-	mW	$I_F = 7\text{ mA}$
$I_{TH}$	Threshold Current <sup>(1)</sup>	0.80	-	3	mA	
$R_S$	Series Resistance <sup>(2)</sup>	20	-	55	ohms	
$\eta$	Slope Efficiency <sup>(3)</sup>	0.28	-	-	mW/mA	
-	Linearity <sup>(4)</sup>	0.00	-	-	-	
$\lambda_P$	Wavelength at Peak Emission	840	850	860	nm	-
$\Delta\lambda$	Optical Bandwidth	-	-	0.85	nm	-
$\theta$	Beam Divergence	-	24	-	Degree	$I_F = 7\text{ mA}$
$N_{RI}$	Relative Intensity Noise	-	-123	-	db/Hz	-
$\Delta I_{TH}/\Delta T$	Temp Coefficient of Threshold Current	-	$\pm 1.0$	-	mA	0° - 70° <sup>(1)</sup>
$\Delta\lambda/\Delta T$	Temp Coefficient of Wavelength	-	0.06	-	%/°C	0° - 70°, $I_F = 7\text{ mA}$
$\Delta V_F/\Delta T$	Temperature Coefficient for $V_F$	-	-2.5	-	mW%/°C	0° - 70°, $I_F = 7\text{ mA}$
$\Delta\eta/\Delta T$	Temperature Coefficient for Efficiency <sup>(3)</sup>	-	-0.5	-	%/C	0° - 70°

Notes:

1. Threshold current is based on the two line intersection method specified in Telcordia GR468-Core. Line 1 from 4 mA to 6mA. Line 2 from 0 mA to 0.5 mA.
2. Series resistance is the slope of the voltage-current line from 5 to 8 mA.
3. Slope efficiency is the slope of the best-fit LI line from 5 mA to 8 mA, using no larger than 0.25 mA test interval points.
4. Using data points taken for slope efficiency above,  $\Delta\lambda/\Delta I$  shall be calculated for each adjacent pair of points.

General Note

TT Electronics reserves the right to make changes in product specification without notice or liability. All information is subject to TT Electronics' own data and is considered accurate at time of going to print.

TT Electronics | Optek Technology, Inc.  
1645 Wallace Drive, Ste. 130, Carrollton, TX USA 75006 | Ph: +1 972 323 2200  
www.ttelectronics.com | sensors@ttelectronics.com

### Performance

OPR2800V - Normalized Output Power vs Forward Current

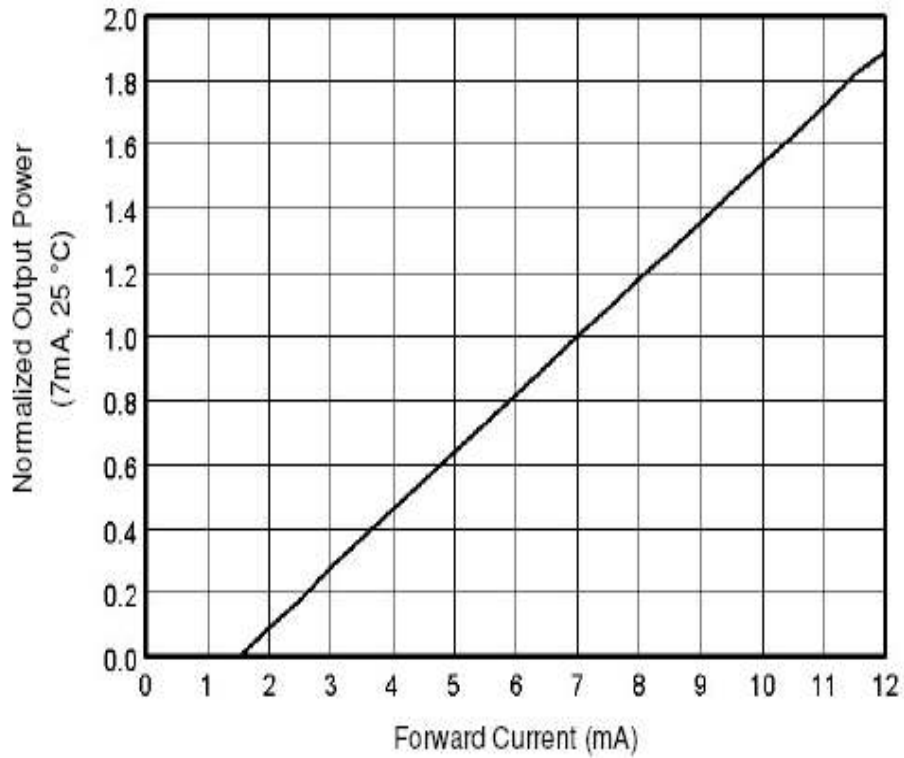

### Performance

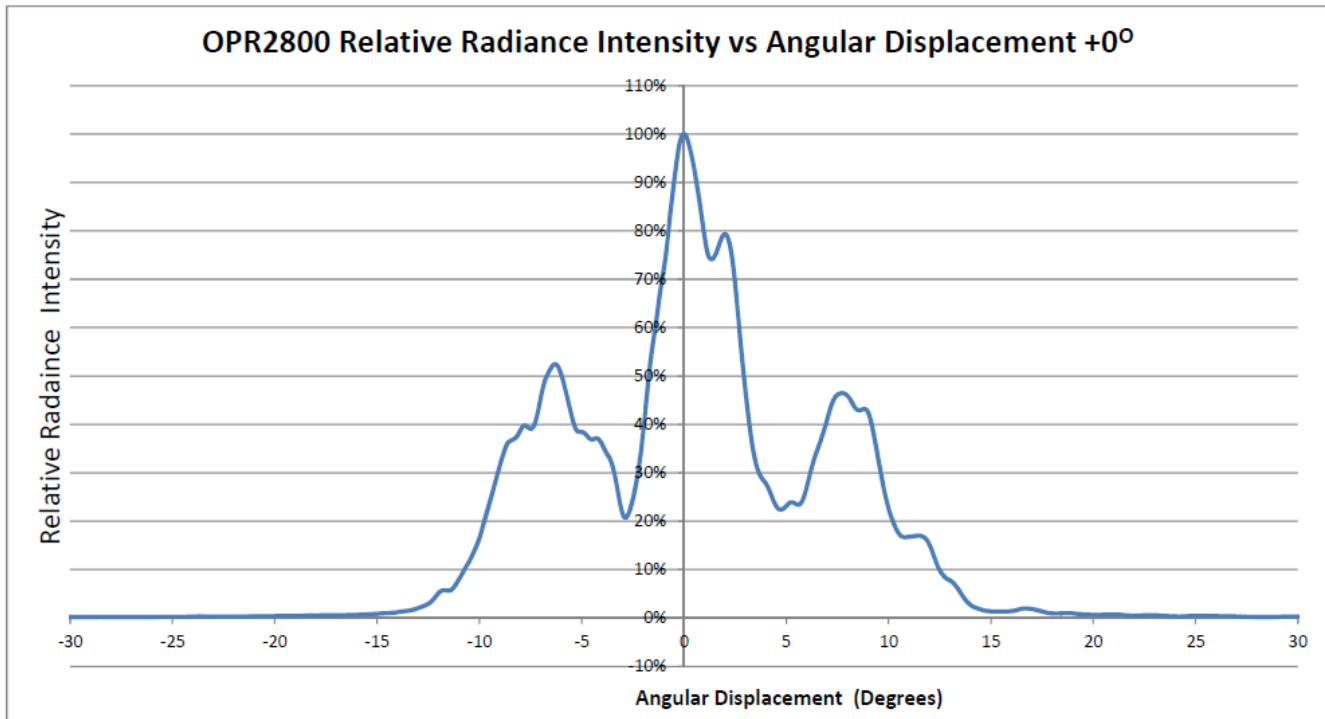

**General Note**

TT Electronics reserves the right to make changes in product specification without notice or liability. All information is subject to TT Electronics' own data and is considered accurate at time of going to print.

TT Electronics | Optek Technology, Inc.  
1645 Wallace Drive, Ste. 130, Carrollton, TX USA 75006 | Ph: +1 972 323 2200  
www.ttelectronics.com | sensors@ttelectronics.com

### Performance

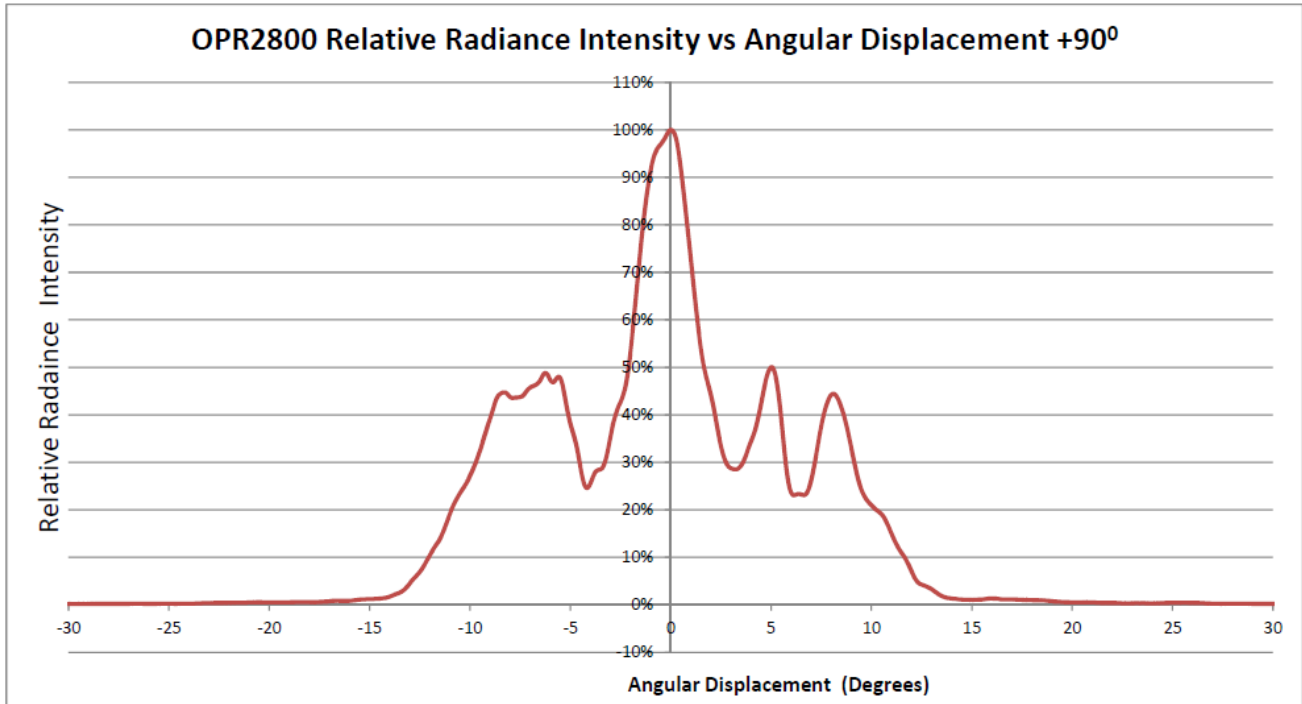

#### General Note

TT Electronics reserves the right to make changes in product specification without notice or liability. All information is subject to TT Electronics' own data and is considered accurate at time of going to print.

TT Electronics | Optek Technology, Inc.  
1645 Wallace Drive, Ste. 130, Carrollton, TX USA 75006 | Ph: +1 972 323 2200  
www.ttelectronics.com | sensors@ttelectronics.com