

THIS DRAWING IS UNPUBLISHED. RELEASED FOR PUBLICATION  
 BY AMP INCORPORATED. ALL RIGHTS RESERVED.

LOC	DIST	REVISIONS					
		P	LTR	DESCRIPTION	DATE	DWN	APVD
AA	22	E		REVISED PER EC 0S11-0140-03	26AUG03	DLD	BDK

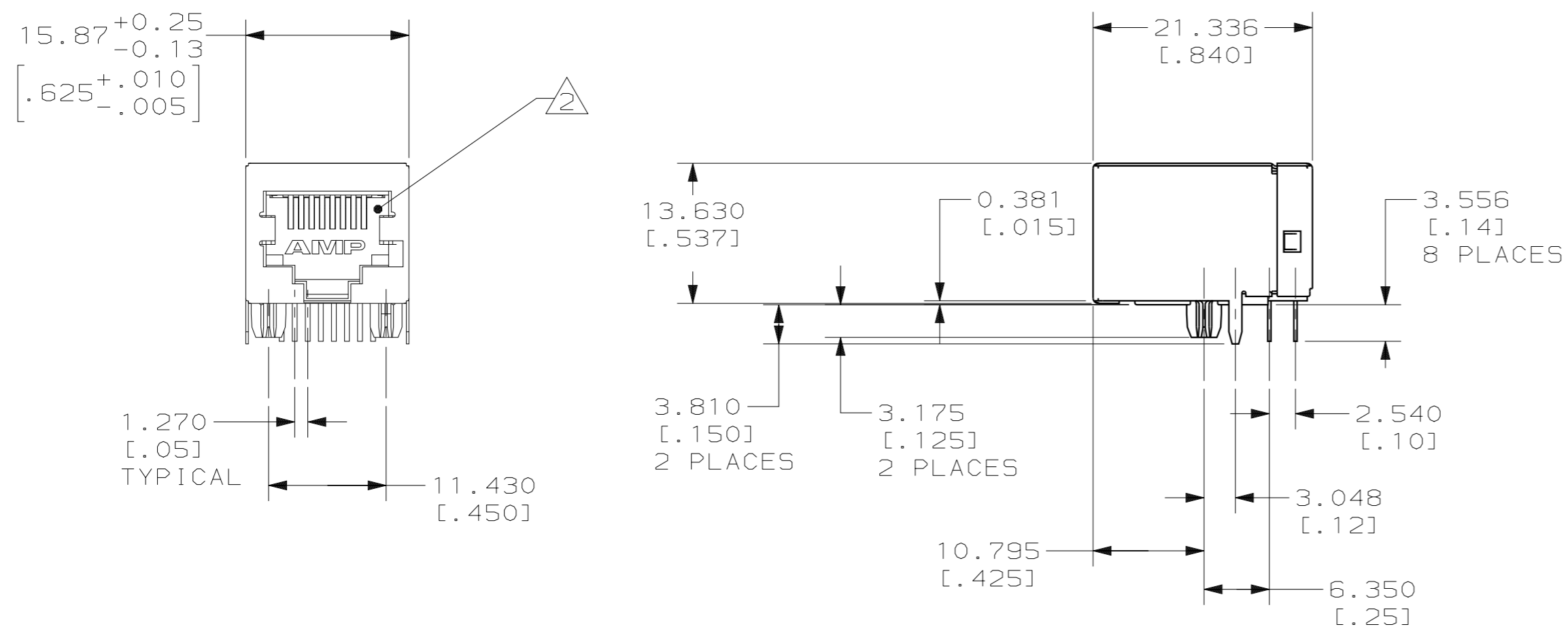

- 1 MATERIAL: HOUSING HIGH TEMPERATURE NYLON, BLACK, IR REFLOW COMPATIBLE, UL 94V-0. TERMINALS - 0.33[.013] THICK PHOS BRONZE PLATED WITH 1.27μm[.000050] MINIMUM THICK HARD GOLD IN LOCALIZED AREA AND 3.81μm [ .000150 ] MINIMUM THICK TIN-LEAD IN SOLDER AREA OVER 1.27μm[.000050] MINIMUM THICK NICKEL UNDERPLATE. SHIELDS - 0.254[.010] THICK COPPER ALLOY PLATED WITH 2.03μm[.000080] MINIMUM TIN-LEAD OVER 2.54μm[.000100] MINIMUM COPPER.
- 2 JACK CAVITY CONFORMS TO FCC RULES AND REGULATIONS, PART 68 SUBPART F.
- 3. ALL DIMENSIONS SHOWN ARE NOMINAL UNLESS OTHERWISE SPECIFIED.
- 4 CAUTION: CATEGORY 5 JACK SOLDER TAIL POSITIONS DO NOT FOLLOW SAME NUMBER SEQUENCE AS THAT OF TRADITIONAL JACKS.
- 5 USE #30 DRILL BIT OR 3.25mm DRILL BIT WHEN PRODUCING THESE PCB HOLES.

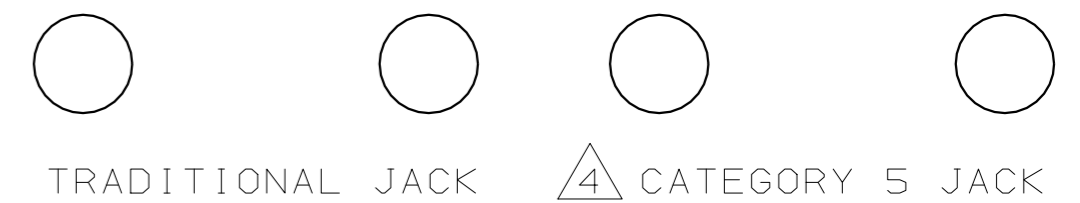
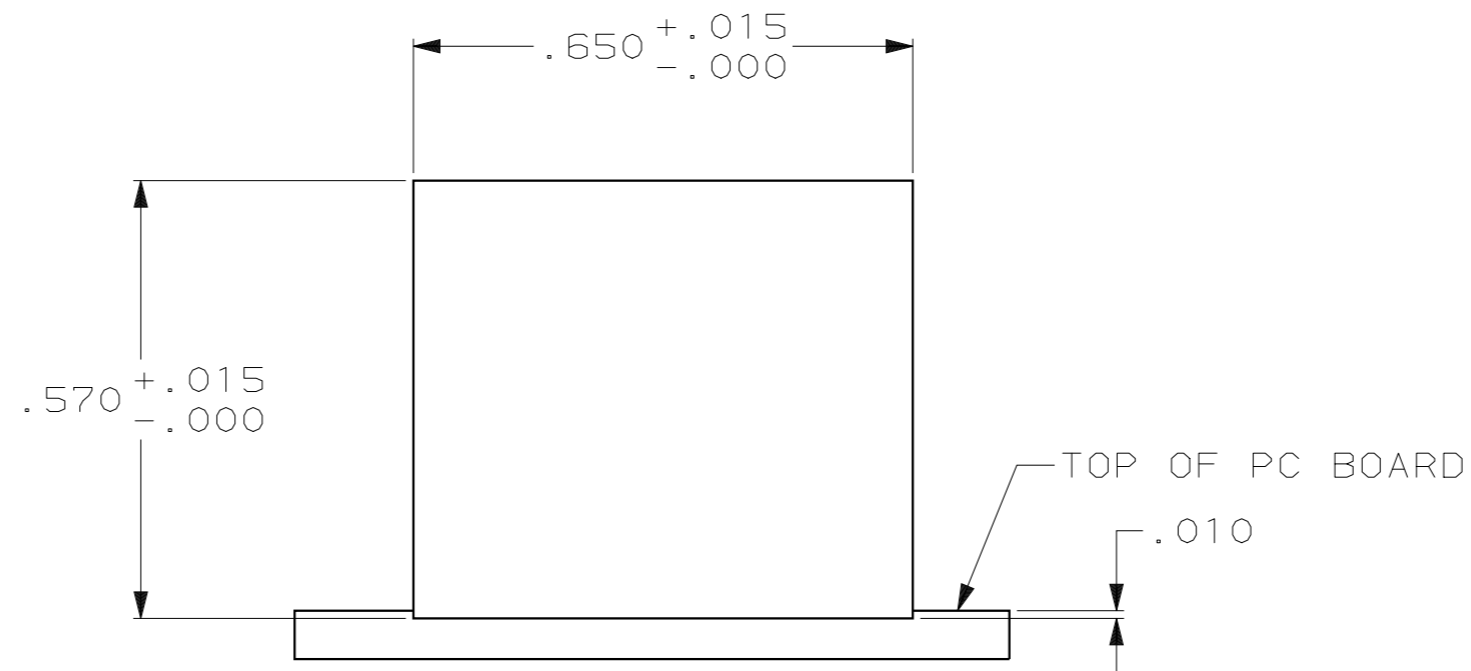
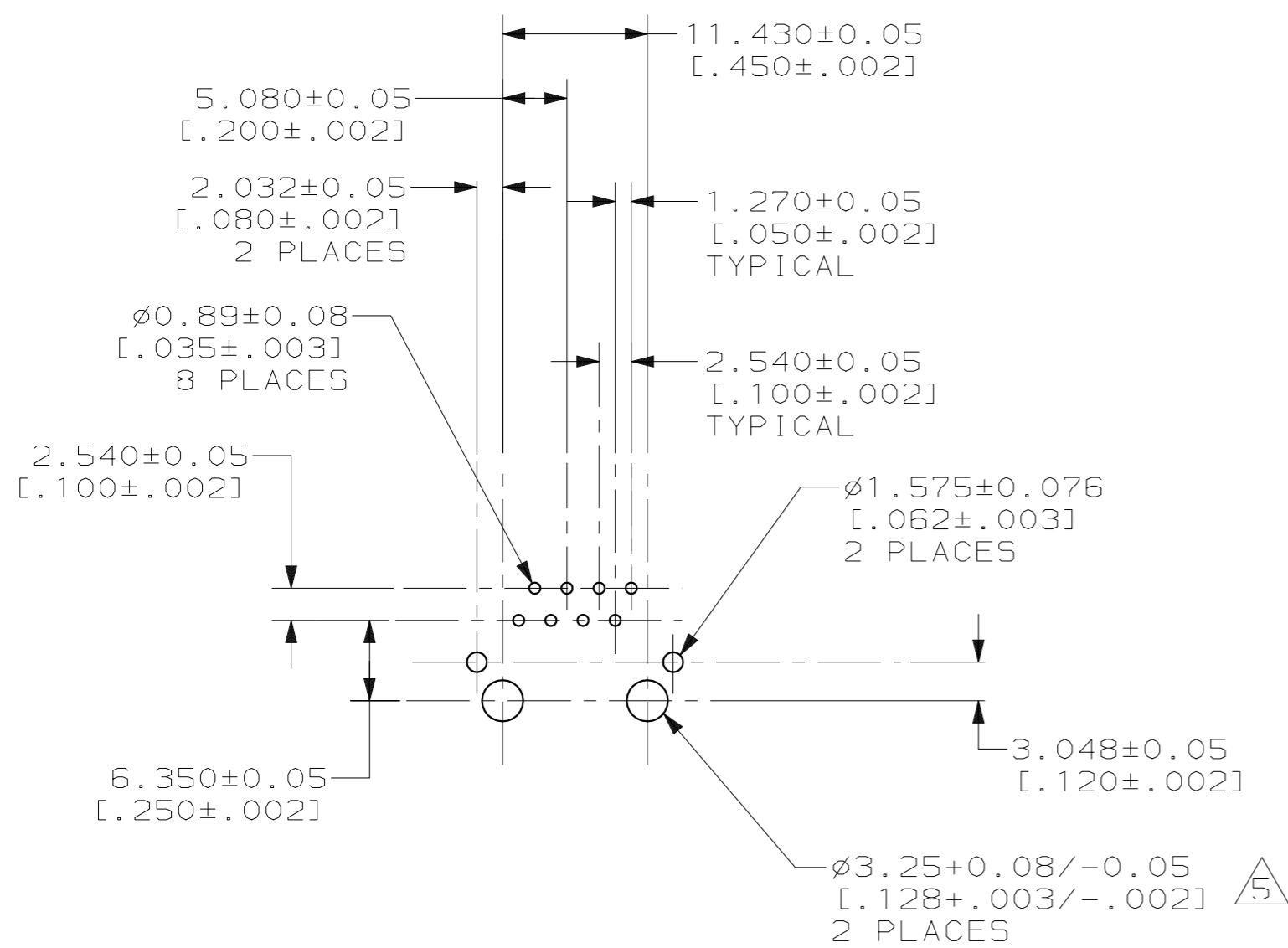

558342-1  
PART NUMBER

SUGGESTED PC BOARD LAYOUT  
COMPONENT SIDE

THIS DRAWING IS A CONTROLLED DOCUMENT FOR AMP INCORPORATED. IT IS SUBJECT TO CHANGE AND THE CONTROLLING ENGINEERING ORGANIZATION SHOULD BE CONTACTED FOR THE LATEST REVISION.		DWN T. PITTS 2-2-94	AMP Incorporated Harrisburg, PA 17105-3608	
DIMENSIONS: mm [INCHES]		CHK B. FOX 2-16-94	NAME MODULAR JACK ASSEMBLY, 8 POSITION, RIGHT ANGLE, LOW PROFILE, SHIELDED, PC BOARD GROUND, CATEGORY 5	
TOLERANCES UNLESS OTHERWISE SPECIFIED: 0 PLC ±- 1 PLC ±- 2 PLC ±0.254 [ .01 ] 3 PLC ±0.127 [ .005 ] 4 PLC ±- ANGLES ±- FINISH ±-		APVD G. REED 2-16-94	PRODUCT SPEC 108-1163	
MATERIAL 1		APPLICATION SPEC 114-2048	SIZE A2	CAGE CODE 00779
		WEIGHT -	DRAWING NO C-558342	
		CUSTOMER DRAWING	SCALE 2:1	SHEET 1 OF 1
			REV E	

558342