

Part. No. for socket connector	
UNC 4-40	M3
15-000050	15-000100

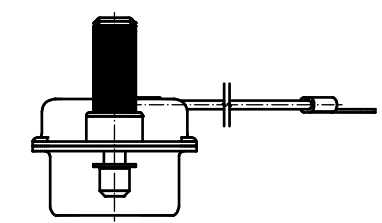
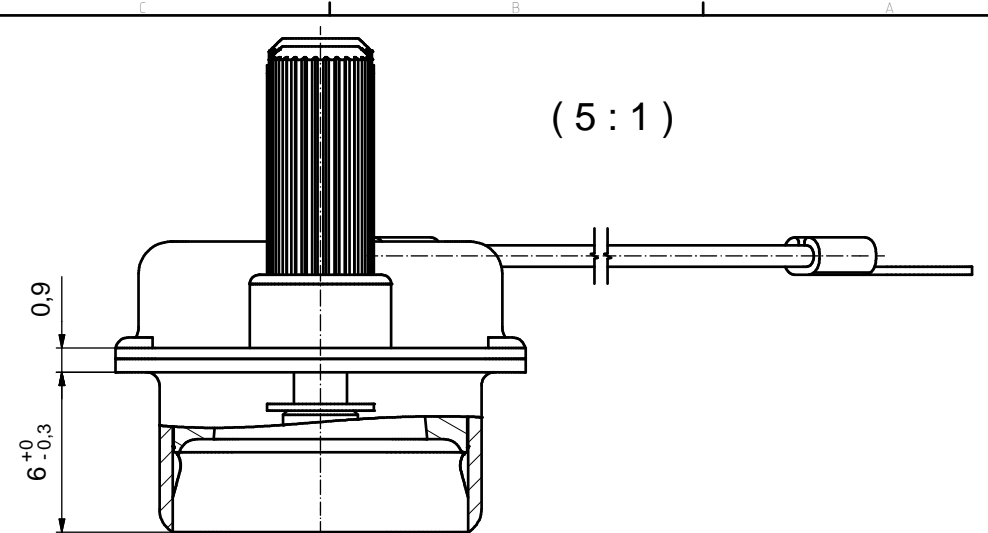

- NOTES:**
- METALSHELLS: COPPER ALLOY; min. 315µin TIN over 40-80µin NICKEL
 - TPE ETHYLENE PROPYLENE THERMOPLASTIC RUBBER SEAL
 - IP RATING: THE WATER RESISTANT CAP MUST BE MOUNTED PROPERLY TO THE MATING CONNECTOR FOR IP 67
 - THREADED INSERT: COPPER ALLOY; min. 200µin TIN over 80µin NICKEL
 - COLLAR: COPPER ALLOY; min. 200µin TIN over 80µin NICKEL
 - JACKSCREW: STAINLESS STEEL 1.4305
 - WIRE ROPE: STAINLESS STEEL 1.4401
 - RETAINING WASHER: STAINLESS STEEL 1.4122
 - TERMINAL RING: UNINSULATED, COPPER ALLOY; min. 200µinTIN over 80µin NICKEL
 - MAXIMUM TORQUE VALUE FOR THREAD: 6in.LB
 - CONNECTOR IS PART MARKED: [PART NO. CONEC ABC]

Directive 2002/95/EC
"RoHS"
Compliant

THIS DRAWING MAY NOT BE COPIED OR REPRODUCED IN ANY WAY, AND MAY NOT BE PASSED ON TO A THIRD PARTY WITHOUT WRITTEN PERMISSION. OWNERSHIP AND COPYRIGHT OF CONEC GmbH DO NOT ALTER CAD DRAWING BY HAND	tolerance		ISO 2768-m	dim. in mm	scale:	2:1 (5:1)
	material:				SEE NOTES	
	date	name	title:			
	drawn	23.05.08	Petker	WATER RESISTANT SCREEN CAP		
appd.	26.05.08	Fischer	50pos. FOR SOCKET CONNECTOR			
norm			with threaded insert, jackscrew and wire rope			
d-old			dwg no:	Inventor 10	DIN-A3	
rev.	description	date	15K1A224		sh: 1	
			part no:		see table	

