

Ultra small size high selectivity type ceramic filter for communication use.

FEATURES

- Ultra small size
- 6.5 mm profile
- Bandwidths from 4KHz to 30KHz available
- High selectivity
- 4 elements

OPERATING CONDITIONS/ELECTRICAL CHARACTERISTICS

PART NUMBER	CENTER FREQUENCY (KHz)	INSERTION LOSS (dB) MAX.	PASS BAND RIPPLE (dB) MAX.	6 dB BANDWIDTH (KHz) MIN.	40 dB BANDWIDTH (dB) MAX.	STOP BAND ATT. ±100KHZ (dB) MIN.	INPUT / OUTPUT IMPEDANCE (Ω)
LTM455BU	455 ±2.0	4	2	±15	±30	27	1500
LTM455CU	455 ±2.0	4	2	±12.5	±24	27	1500
LTM455DU	455 ±1.5	4	2	±10	±20	27	1500
LTM455EU	455 ±1.5	6	2	±7.5	±15	27	1500
LTM455FU	455 ±1.5	6	2	±6	±12.5	27	2000
LTM455GU	455 ±1.0	6	2	±4.5	±10	25	2000
LTM455HU	455 ±1.0	6	2	±3	±9	25	2000
LTM455IU	455 ±1.0	6	2	±2	±7.5	25	2000
LTM455HTU	455 ±1.0	6	2	±3	±9	35	2000
LTM455ITU	455 ±1.0	6	2	±2	±7.5	35	2000

PACKAGE DIMENSIONS (mm)

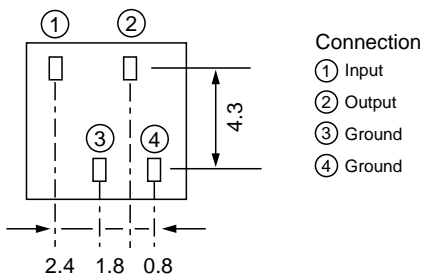
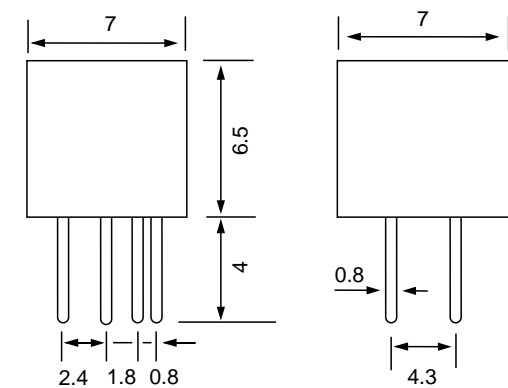

Figure 1) LTM455U – Front, Side and Bottom views

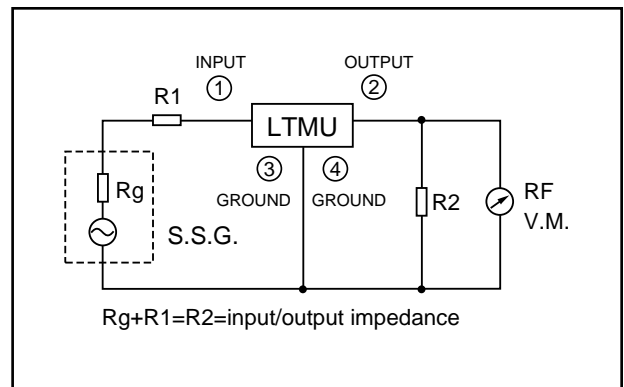

Figure 2) LTM455U – Measuring Circuit

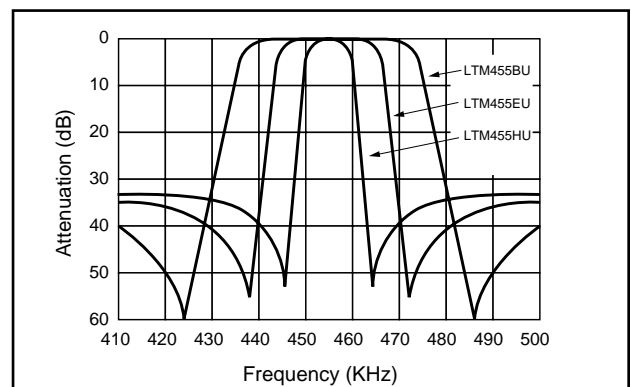

Figure 3) LTM455U – Characteristics

Note: To avoid potential problems, connect the output to an IF amplifier through a DC cut capacitor. Avoid applying a direct current to output end of the ceramic filters (between ③ and ①②).