

# Customer Information Sheet

DRAWING No.: S9091-46R

IF IN DOUBT - ASK

©

NOT TO SCALE

THIRD ANGLE PROJECTION

ALL DIMENSIONS IN mm

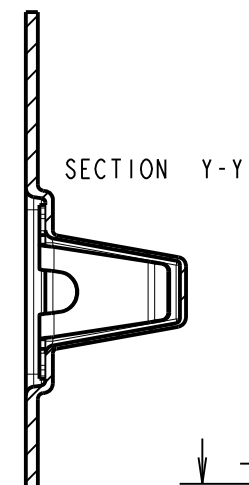
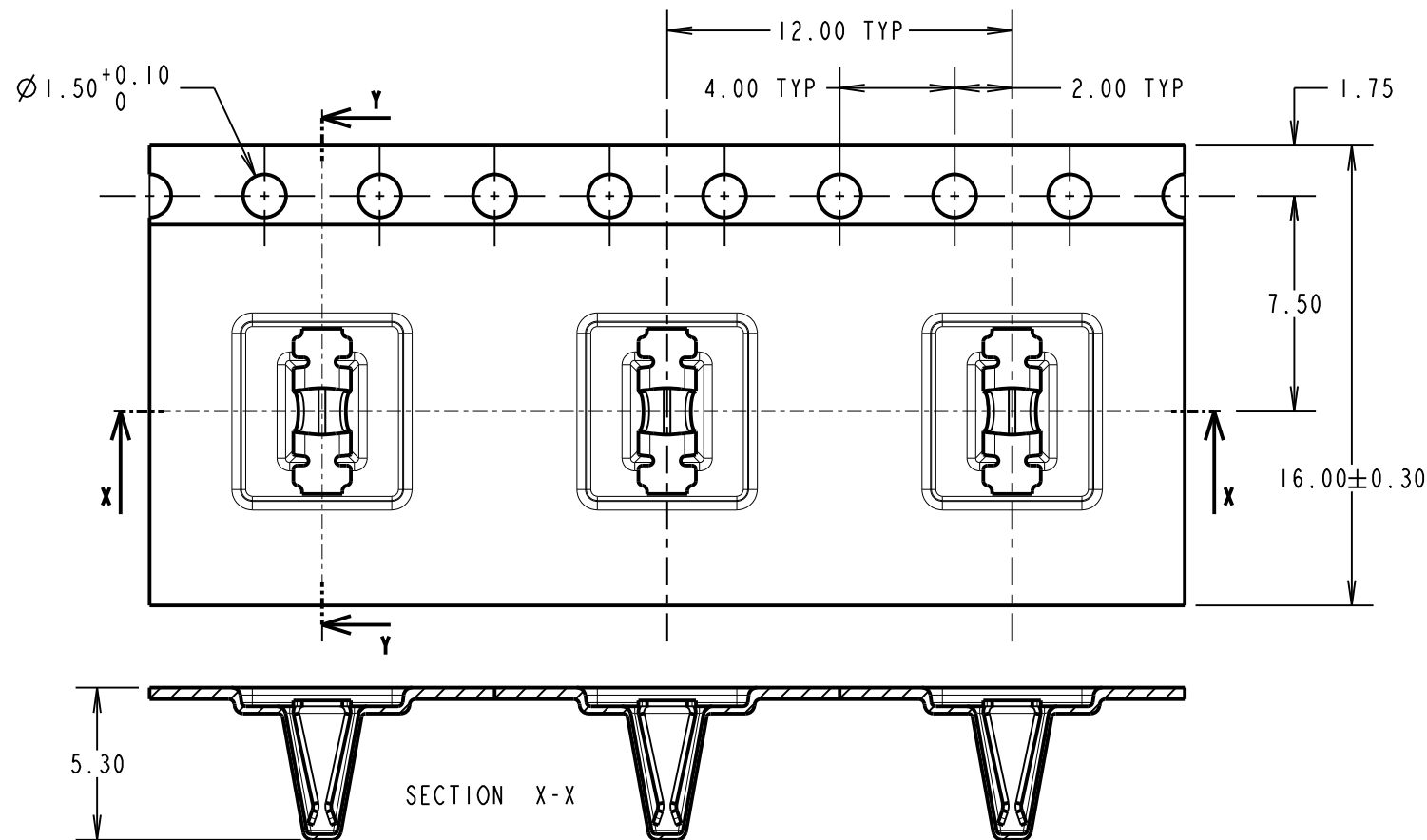

- NOTES:
1. QUANTITY OF COMPONENTS PER REEL = 900.
  2. THIS PRODUCT IS TAPED AND REELED IN GENERAL ACCORDANCE WITH EIA-481-2 (ELECTRONICS INDUSTRIES ASSOCIATION).
  3. RECOMMENDED MINIMUM PIN SIZE IS  $\varnothing 0.80\text{mm}$  OR  $0.80\text{mm}$  SQUARE. RECOMMENDED MAXIMUM PIN SIZE IS  $\varnothing 1.50\text{mm}$  OR  $1.50\text{mm}$  SQUARE.
  4. THROUGHOUT OPERATION, IT IS RECOMMENDED THAT THE MATING PIN IS KEPT CONSISTENT. THIS WILL REDUCE RISK OF PERFORMANCE CHANGES CAUSED BY PERMANENT SET FROM PREVIOUSLY USING A LARGER PIN.

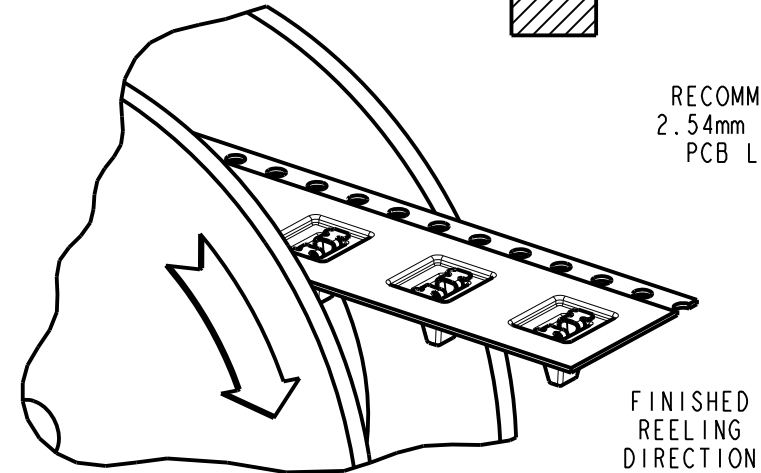
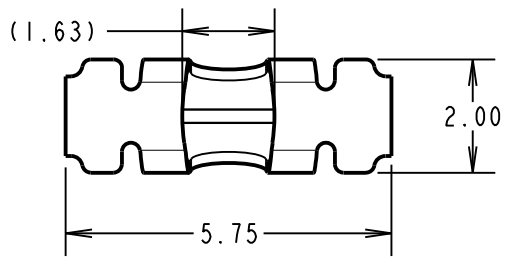
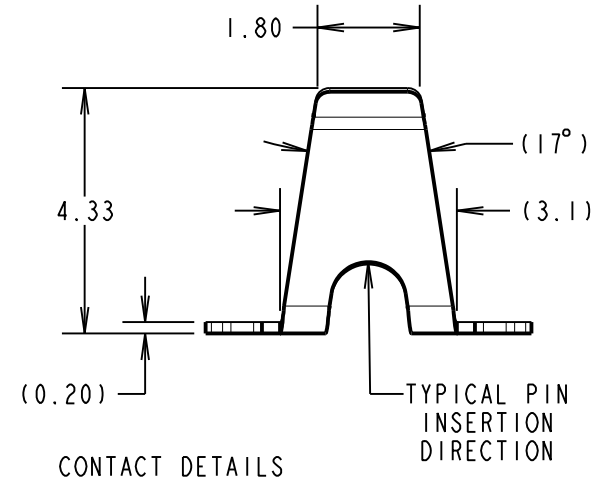
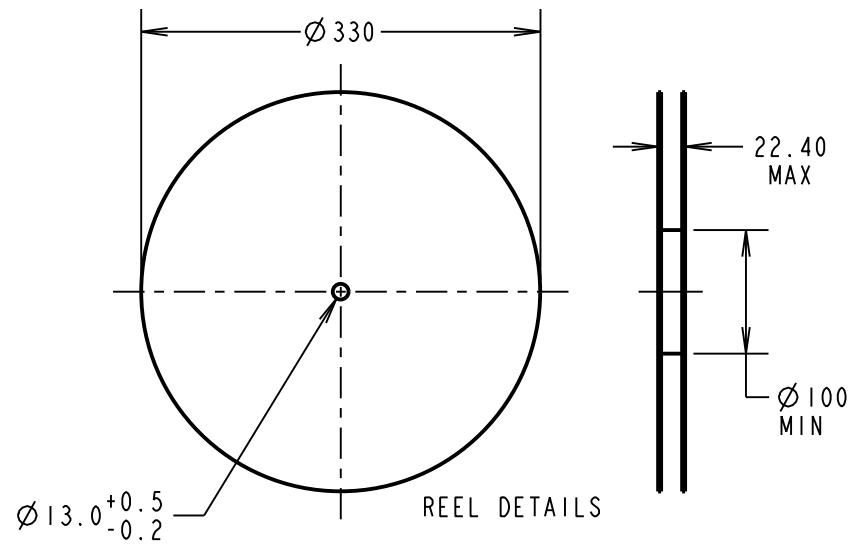
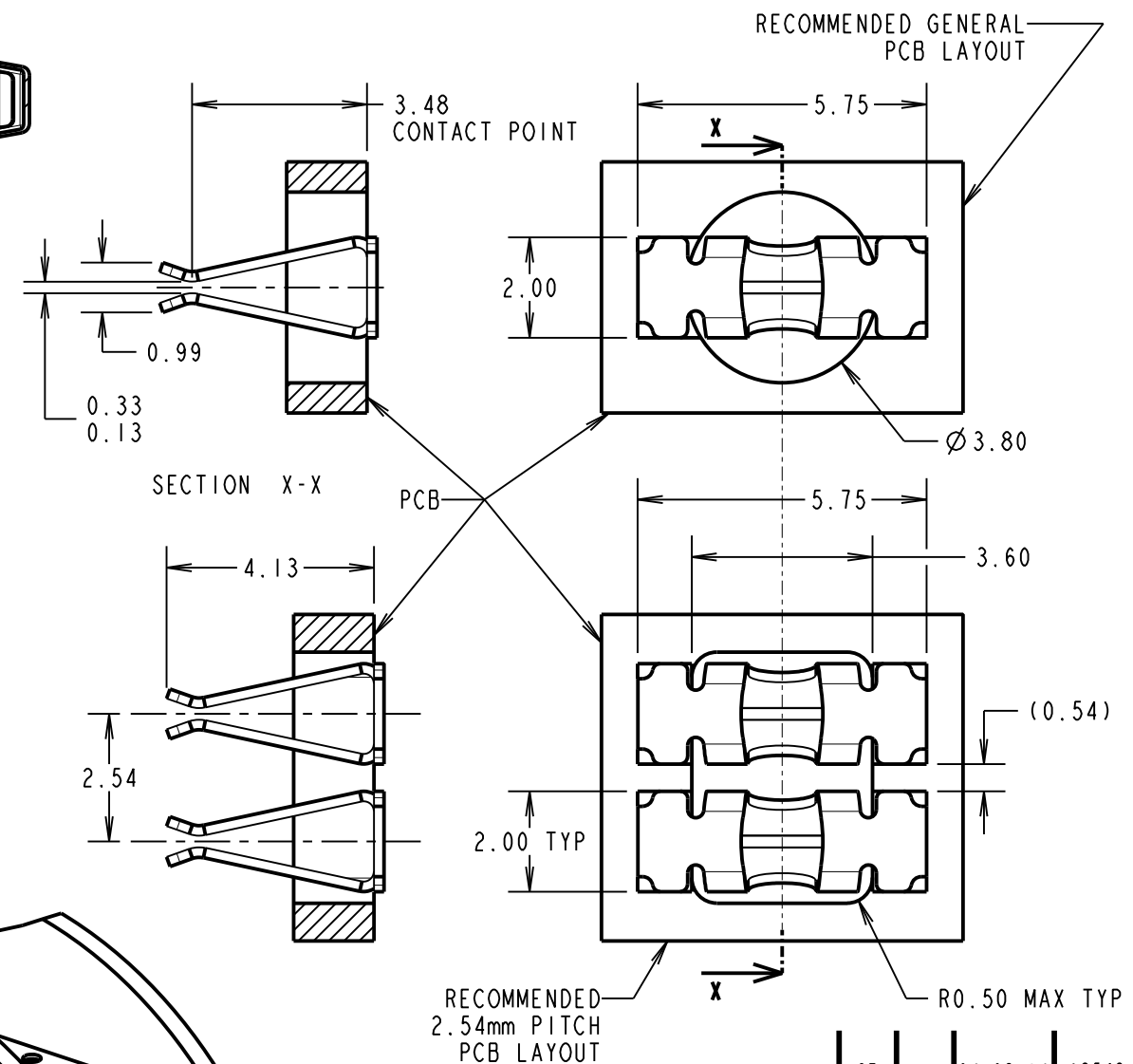

**COMPONENT SPECIFICATION:**  
 MATERIAL = PHOSPHOR BRONZE  
 FINISH = 4.0-5.0 $\mu$  100% TIN OVER 2.0-2.5 $\mu$  NICKEL  
**ELECTRICAL:**  
 CURRENT RATING = 5A  
 CONTACT RESISTANCE = 20m $\Omega$  MAX  
 DURABILITY = 25 CYCLES  
**MECHANICAL:**  
 MAX INSERTION FORCE WITH  $\varnothing 1.00\text{mm}$  PIN = 8.0N  
 MAX INSERTION FORCE WITH  $\varnothing 1.50\text{mm}$  PIN = 17.0N  
 MIN WITHDRAWAL FORCE WITH  $\varnothing 1.00\text{mm}$  PIN = 0.5N  
 MIN WITHDRAWAL FORCE WITH  $\varnothing 1.50\text{mm}$  PIN = 1.0N  
**ENVIRONMENTAL:**  
 OPERATING TEMPERATURE = -40°C TO +105°C

SB	1	04.08.14	12548
NAME	ISS.	DATE	C/NOTE
APPROVED:		S.BENNETT	
CHECKED:		S.FLOWER	
DRAWN:		S.BENNETT	
CUSTOMER REF.:			
ASSEMBLY DRG:			

**HARWIN**  
 www.harwin.com  
 technical@harwin.com

THIS DRAWING AND ANY INFORMATION OR DESCRIPTIVE MATTER SET OUT HEREON ARE CONFIDENTIAL AND COPYRIGHT PROPERTY OF THE HARWIN GROUP AND MUST NOT BE DISCLOSED, LOANED, COPIED OR USED FOR MANUFACTURING, TENDERING OR FOR ANY OTHER PURPOSE WITHOUT THEIR WRITTEN PERMISSION.

**TOLERANCES**  
 X. =  $\pm 1\text{mm}$   
 X.X =  $\pm 0.25\text{mm}$   
 X.XX =  $\pm 0.10\text{mm}$   
 X.XXX =  $\pm 0.01\text{mm}$   
 ANGLES =  $\pm 5^\circ$   
 UNLESS STATED

**MATERIAL:** SEE ABOVE  
**FINISH:** SEE ABOVE  
**S/AREA:** mm<sup>2</sup>

**TITLE:** SMT SOCKET CONTACT IN TAPE AND REEL  
**DRAWING NUMBER:** S9091-46R  
 SHT 2 OF 2