

REV.	DESCRIPTION/ECO NO.	DATE
	RELEASED AS CAD	9/12/02
A	ADD SOCKET DIMENSIONS	1/10/06
B	ADD WIRE TYPE	7/11/12
C	DIM 2.03.2±6.35 TO 203.2±8.00	8/21/18

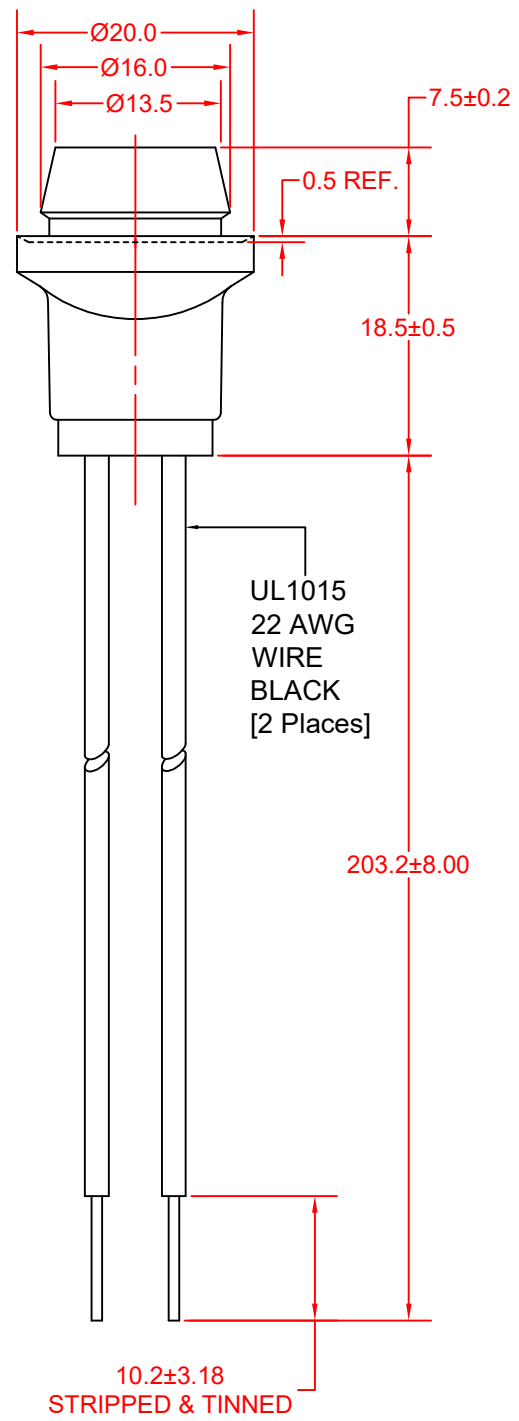

PLASTIC PANEL

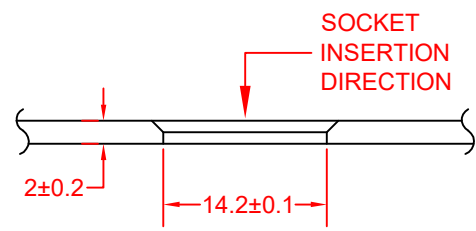

METAL PANEL

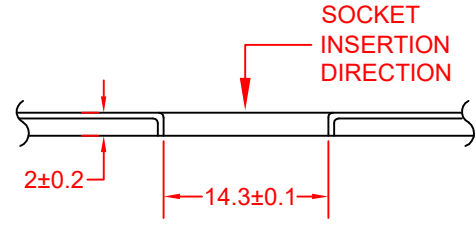

BASE COLOR: GRAY  
 LEAD COLORS: BLACK

JKL PART NO.: 2964-8B

 THIRD ANGLE PROJECTION	METRIC DIMENSIONS ARE IN MILLIMETERS TOLERANCE UNLESS OTHERWISE SPECIFIED 1 PL +/- 0.2 2 PL +/- 0.20 ANGLE +/- 0	<b>JKL COMPONENTS CORPORATION</b>			
	TITLE <b>T-3 1/4 PUSH-IN TYPE SOCKET</b>				
DRAWN BY L. WENGSTROM	APPV'D BY S.C.	DATE 8/21/18	SIZE <b>A</b>	FSCM NO. <b>55335</b>	DRAWING NO. <b>SOCKET 2964-8B</b>
- CAD DRAWING - MANUAL REVISIONS NOT PERMITTED			SCALE <b>NONE</b>	RELEASED DATE 9/12/02	REVISION DATE 8/21/18
				REV. NO. <b>C</b>	SHEET 1 OF 1