

P.C.B. HOLE DRILLINGS  
(P.C.B. TOP SIDE)

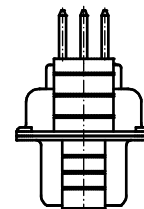

NOTES:

1. METALSHELLS: STEEL; min. 315µm TIN over 40-80µm NICKEL
2. INSULATORS: PBT GF UL 94 V-0, BLACK
3. CONTACTS: COPPER ALLOY; PLATING (SEE PART NO):
  - PLEASE ADD A for GOLD FLASH over NICKEL (PREFERRED TYPE)
  - PLEASE ADD B for 20µm HARD GOLD over min. 50µm NICKEL
  - PLEASE ADD C for 30µm HARD GOLD over min. 50µm NICKEL
4. THREADED REAR SPACERS / FRONT THREADED LOCKS: COPPER ALLOY; 200µm TIN over 80µm NICKEL
5. SLEEVES: COPPER ALLOY; min. 200µm TIN over 80µm NICKEL
6. MAXIMUM TORQUE VALUE FOR THREAD: 6 in.LB
7. CONNECTOR IS PART MARKED: 164□17339X CONEC ABC

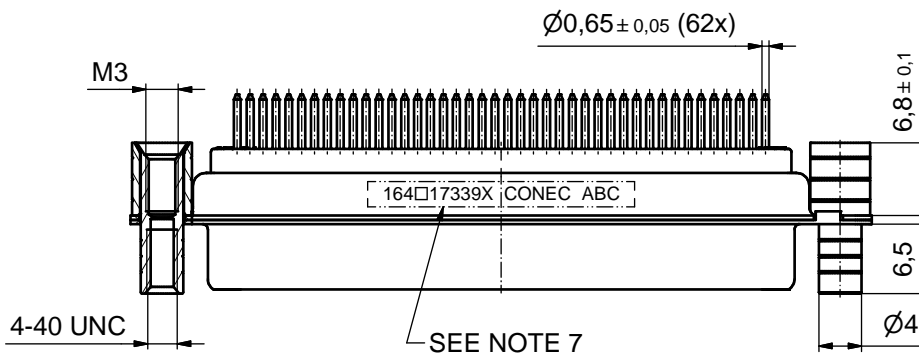
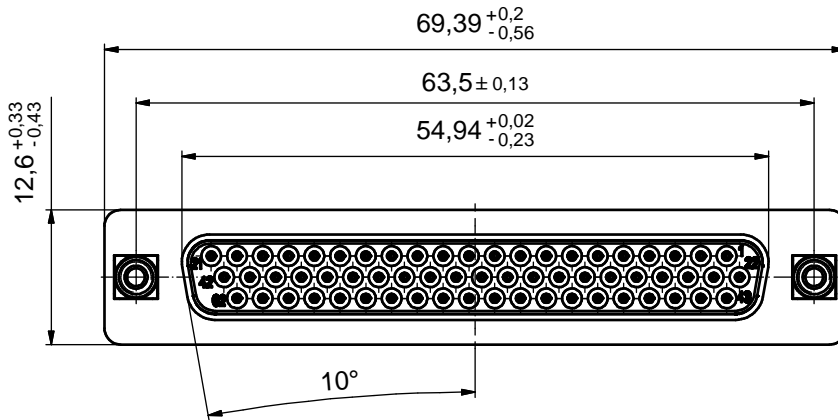
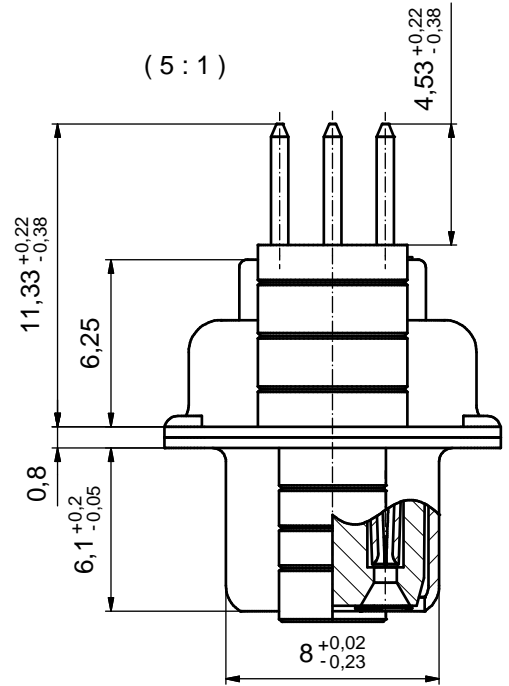
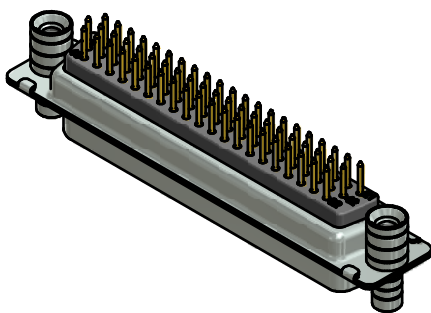

Directive 2002/95/EC RoHS compliant

THIS DRAWING MAY NOT BE COPIED OR REPRODUCED IN ANY WAY, AND MAY NOT BE PASSED ON TO A THIRD PARTY WITHOUT WRITTEN PERMISSION. OWNERSHIP AND COPYRIGHT OF CONEC GmbH				tolerance		dim. in mm	scale: 2:1 (5:1)	
				date			material: SEE NOTES	
DO NOT ALTER CAD DRAWING BY HAND				name		title: D-SUB HD FEMALE 62pos. SOLDER PIN STRAIGHT with threaded rear spacer / front threaded lock		
				date				
a Original				drawn	21.11.12	Schmidt	dwg no: 16K1A3144	
				appd.	21.11.12	Fischer		
rev. description date name				norm			part no: 164□17339X (see note 3)	
				d-old				
CONEC®								