

THIS DRAWING IS UNPUBLISHED. RELEASED FOR PUBLICATION
 © COPYRIGHT - By - ALL RIGHTS RESERVED.

LOC	DIST	REVISIONS			
P	LTR	DESCRIPTION	DATE	DWN	APVD
AF	50	S2	REVISED PER ECR-19-017995	02DEC2019	PC MK

- 1 PRODUCT PROVIDED IN STRIP FORM ON REELS;
BREAKS MAY BE PRESENT
- 2 STANDARD REELING.
- 3 REVERSE REELING.
- 4 CRIMP WIDTH: .180 F TYPE
CRIMP HEIGHT: (±.002) = (TOTAL CMA + 28,300) / 289,800
FOR APPLICATOR INFORMATION CALL: 1-800-722-1111
FOR PRODUCT INFORMATION CALL: 1-800-522-6752
- 5 WIRE RANGE FOR NEW APPLICATIONS: 7000-12,000 CMA
(WIRE RANGE APPROVED FOR APPLICATIONS IMPLEMENTED
PRIOR TO 2005: 9000-16,000 CMA).

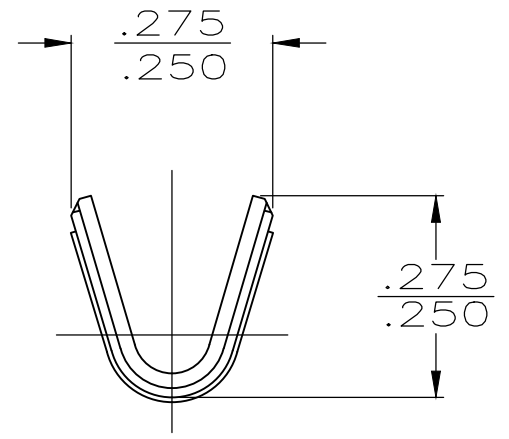
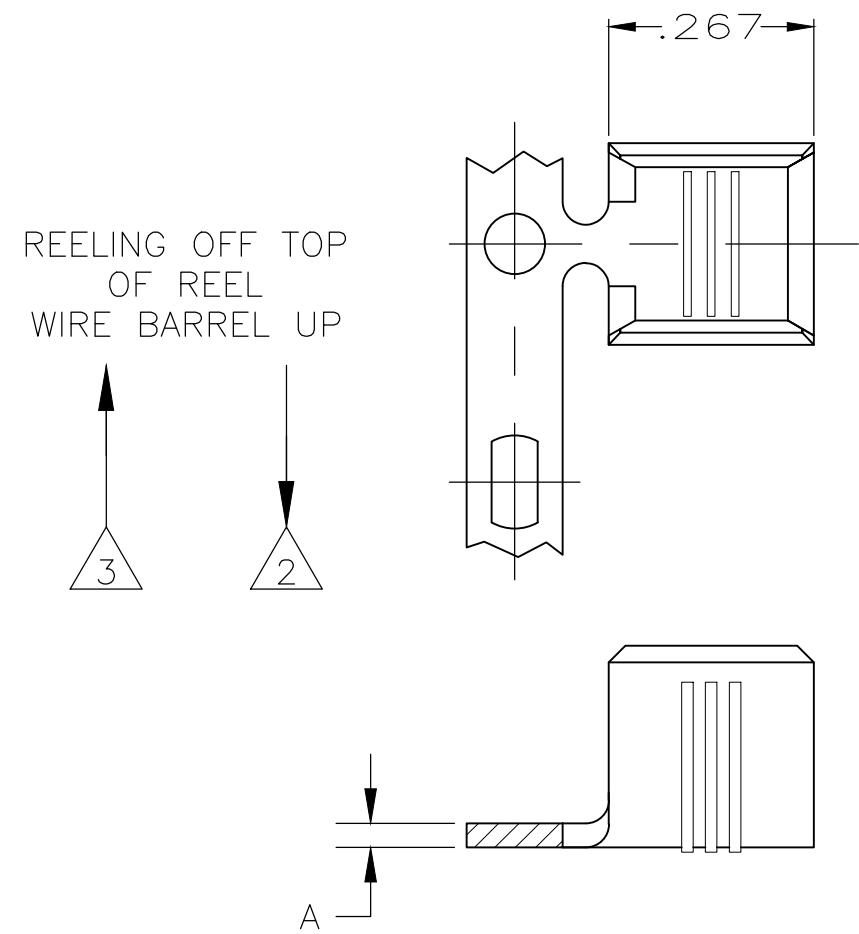

	3	.031±.001	5	TIN	STEEL	61299-8
OBSOLETE						61299-6
OBSOLETE						61299-5
	2	.032±.001	5	NONE	BRASS	61299-3
		.031±.001			TIN	STEEL
REELING	A			FINISH	MATERIAL	PART NUMBER

THIS DRAWING IS A CONTROLLED DOCUMENT.

DIMENSIONS: INCHES

TOLERANCES UNLESS OTHERWISE SPECIFIED:

0 PLC	± -
1 PLC	± -
2 PLC	± -
3 PLC	± .010
4 PLC ANGLES	± -

MATERIAL: SEE TABLE

FINISH: SEE TABLE

APVD: GARY PORTA 19DEC2002

CHK: GARY PORTA 19DEC2002

NAME: GARY PORTA

PRODUCT SPEC: -

APPLICATION SPEC: 114-2088

WEIGHT: -

STE TE Connectivity

SPLICE

SIZE: A3 CAGE CODE: 00779 DRAWING NO: C-61299

RESTRICTED TO: -

CUSTOMER DRAWING

SCALE: 4:1 SHEET: 1 OF 1 REV: S2