

AG932-07E Rotation Sensor Evaluation Kit

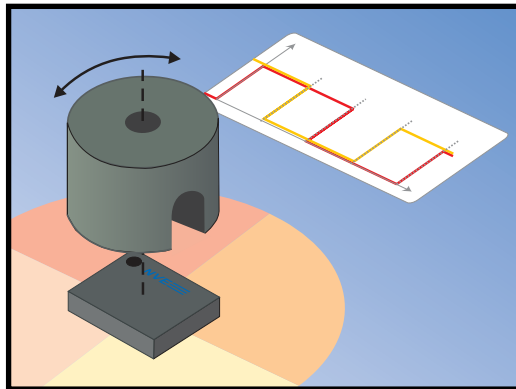

SB-00-047A

Kit Overview

Included in the Evaluation Kit

- ADT002-10E rotation sensor
- Part # 12426 split-pole Alnico 5 round horseshoe magnet
- Circuitry and indicators for direction and quadrant
- Plastic magnet locating fixture
- Battery powered

ADT001/ADT002 Sensor Features

- Extremely low power (3 μ A typ. at 3.3 V)
- Wide airgap tolerance
- Integrated fault detection
- 2.4 V to 5.5 V supply range
- -40°C to $+125^{\circ}\text{C}$ operating range
- Ultraminiature TDFN6 package

ADT001/ADT002 Applications

- Water meters
- Rotational speed sensors
- Rotational position sensors

ADT001/ADT002 Sensor Description

The ADT001 and ADT002 rotation sensors are ultralow power, digital-output magnetic rotational sensors. Two outputs are 90 degrees out of phase to provide directional information. The ADT001 is high hysteresis for high noise immunity in applications such as speed sensing; the ADT002 is low hysteresis to provide accurate, absolute rotational quadrant information.

An additional output indicates a fault if the magnetic field is too high for accurate measurements. This can occur if the magnet is too close to the sensor, or with interference from an adjacent magnet.

The heart of the unique sensor is an array of four Tunneling Magnetoresistance (TMR) elements in each quadrant. TMR technology enables low power and miniaturization, making the sensors ideal for battery operation.

Visit www.nve.com for complete product specifications and reference designs.

Quick Start

- ⇒ Place the horseshoe magnet in the Plexiglas pocket.
- ⇒ Ensure both power jumpers are in place.
- ⇒ Turn the power switch ON.
- ⇒ Rotate the magnet and observe the indicator LEDs.
- ⇒ Turn the power OFF when not in use so the LEDs do not drain the battery.

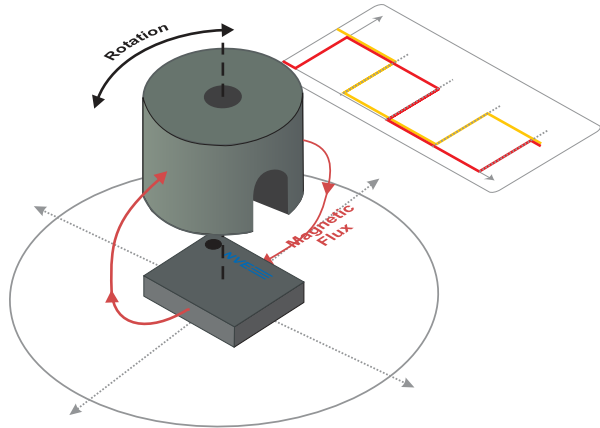

Magnets

The sensor is accurate over a wide range of magnet spacing, especially with the relatively strong magnet provided with the kit. Smaller or weaker magnets may require closer spacing.

Low-cost radially-magnetized ferrite disk magnets can be used with these sensors in production. Bar magnets can also be used in some configurations.

Evaluation Board Layout

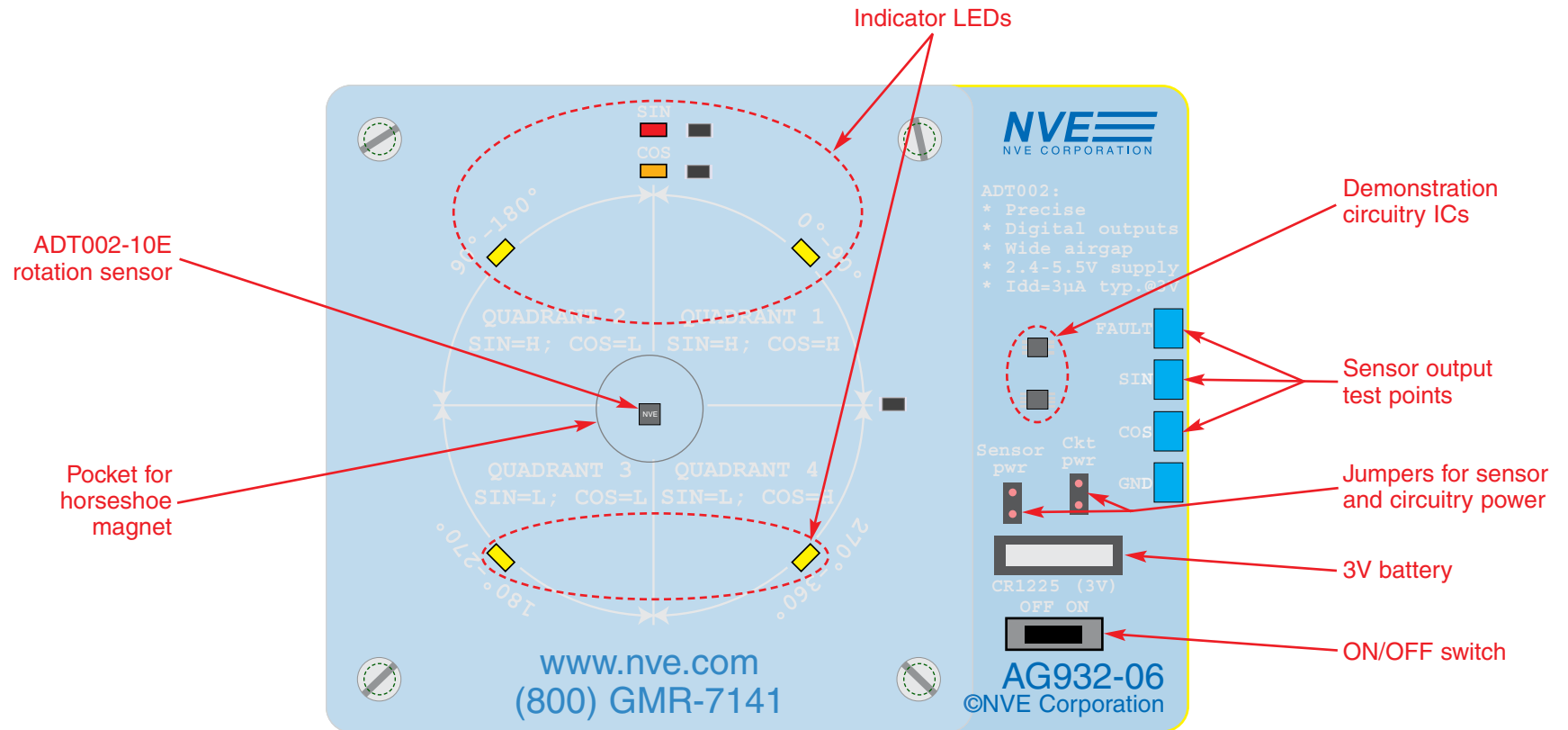

Overview of Operation

ADT00X sensors contain four sensor elements—one in each quadrant. In a typical sensor configuration, an external magnet provides a saturating magnetic field (30 to 200 Oe) in the plane of the sensor, as demonstrated in this kit. Mathematically, the outputs correspond to the sign of the sine and cosine of the rotation, i.e., $\text{sgn}(\sin\theta)$ and $\text{sgn}(\cos\theta)$, as shown below:

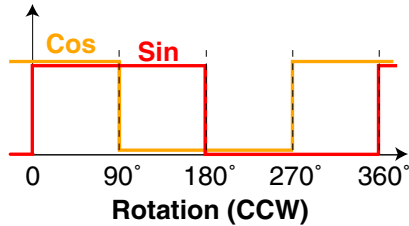

The sensor truth table is as follows:

Angle	Output	
	Sin	Cos
0°-90°	H	H
90°-180°	H	L
180°-270°	L	L
270°-360°	L	H

Thus the sensor outputs define the quadrant of rotation:

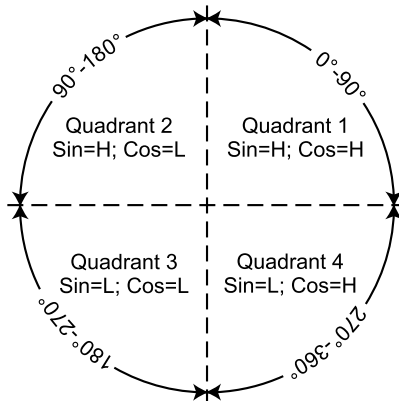

Evaluation Board Circuitry

The PCB assembly includes simple circuitry to drive LEDs from the sensor outputs.

A 3-volt lithium button cell powers the evaluation board. Jumpers allow the circuitry to be disabled or powered separately, or jumper connections can be used to monitor the remarkably low sensor supply current.

The indicator LEDs are driven by 74LVC-Series CMOS logic. A 74LVC2G34 buffer drives red and orange indicator LEDs for the Sin and Cos sensor outputs. A 74LVC1G139 decodes the sensor truth table, providing four outputs that drive the quadrant-indicating yellow LEDs.

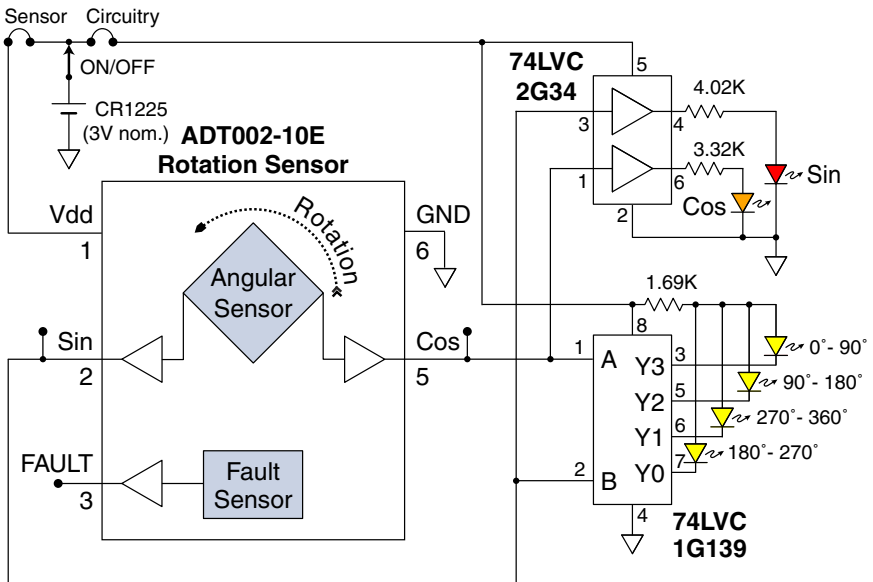

Limited Warranty and Liability

Information in this document is believed to be accurate and reliable. However, NVE does not give any representations or warranties, expressed or implied, as to the accuracy or completeness of such information and shall have no liability for the consequences of use of such information. In no event shall NVE be liable for any indirect, incidental, punitive, special or consequential damages (including, without limitation, lost profits, lost savings, business interruption, costs related to the removal or replacement of any products or rework charges) whether or not such damages are based on tort (including negligence), warranty, breach of contract or any other legal theory.

Right to Make Changes

NVE reserves the right to make changes to information published in this document including, without limitation, specifications and product descriptions at any time and without notice.

Use in Life-Critical or Safety-Critical Applications

Unless NVE and a customer explicitly agree otherwise in writing, NVE products are not designed, authorized or warranted to be suitable for use in life support, life-critical or safety-critical devices or equipment. NVE accepts no liability for inclusion or use of NVE products in such applications and such inclusion or use is at the customer's own risk. Should the customer use NVE products for such application whether authorized by NVE or not, the customer shall indemnify and hold NVE harmless against all claims and damages.

Applications

Applications described in this document are illustrative only. NVE makes no representation or warranty that such applications will be suitable for the specified use without further testing or modification. Customers are responsible for the design and operation of their applications and products using NVE products, and NVE accepts no liability for any assistance with applications or customer product design. It is customer's sole responsibility to determine whether the NVE product is suitable and fit for the customer's applications and products planned, as well as for the planned application and use of customer's third party customers. Customers should provide appropriate design and operating safeguards to minimize the risks associated with their applications and products. NVE does not accept any liability related to any default, damage, costs or problem which is based on any weakness or default in the customer's applications or products, or the application or use by customer's third party customers. The customer is responsible for all necessary testing for the customer's applications and products using NVE products in order to avoid a default of the applications and the products or of the application or use by customer's third party customers. NVE accepts no liability in this respect.

An ISO 9001 Certified Company

NVE Corporation
11409 Valley View Road
Eden Prairie, MN 55344-3617

©NVE Corporation

All rights are reserved. Reproduction in whole or in part is prohibited without the prior written consent of the copyright owner.

Manual No.: SB-00-047A