

NOTICE OF PROPRIETARY RIGHTS THIS DOCUMENT CONTAINS CONFIDENTIAL TECHNICAL DATA, INCLUDING TRADE SECRETS, PROPRIETARY TO TIMES MICROWAVE SYSTEMS. DISCLOSURE OF THIS DATA IS EXPRESSLY CONDITIONED UPON YOUR ASSENT THAT ITS USE IS LIMITED TO USE WITHIN YOUR COMPANY ONLY. ANY OTHER USE IS STRICTLY PROHIBITED WITHOUT THE PRIOR WRITTEN CONSENT OF TIMES MICROWAVE SYSTEMS.

SYM	REVISION DESCRIPTION	DFTM	DATE	APPD	DATE
A	RELEASED FOR PRODUCTION	K.A.M.	6/3/11	J.D.B.	6/3/11
B	CHANGED PER CDC #34607/36250	D.J.H.	9/24/12	J.D.B.	9/25/12

RECOMMENDED CABLE STRIPPING DIM'S.

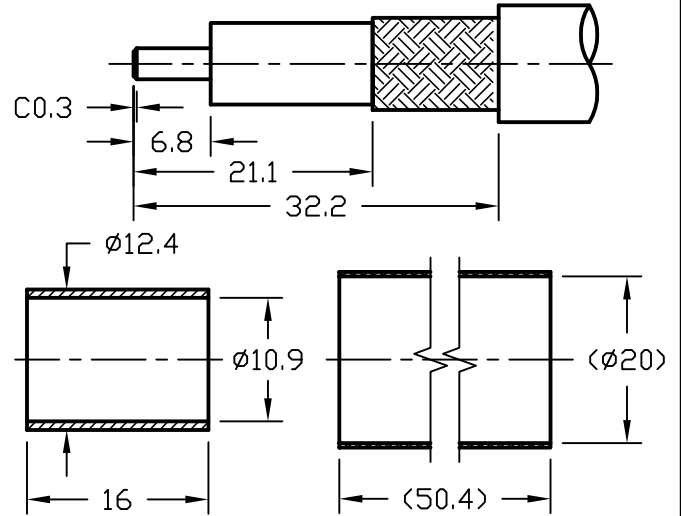
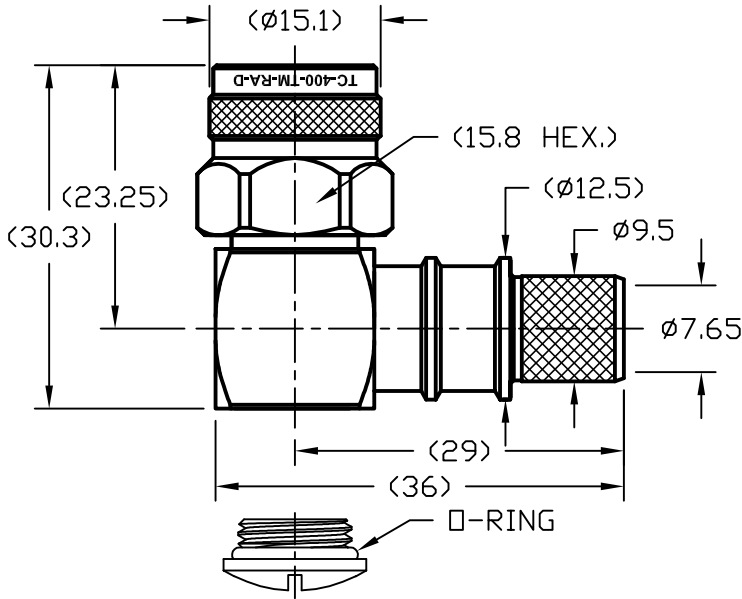

NOTES:

- CONTACT PIN IS SOLDERED.
- FERRULE IS CRIMPED TO .429" HEX.

ALL PARTS SATISFIED ROHS REQUIREMENTS

MATERIALS AND PLATING		UNIT: MICRO-INCHES
BODY/SHELL	BRASS C3604	ALBALOY 80 MIN/COPPER
CONTACT PIN	BRASS C3604	GOLD 50 MIN/NICKEL/COPPER
INSULATOR	TEFLON MIL-P-19468	N/A
GASKET	SILICONE	RED
FERRULE	BRASS	ALBALOY 80 MIN/COPPER
SHRINK TUBING	PO	BLACK

ELECTRICAL CHARACTERISTICS	
Impedance	50 Ω
Frequency range	0~11GHz
Voltage rating	500V(rms)
Dielectric withstanding voltage	1000V
Contact resistance	Center contact ≤ 3 m Ω
	Outer contact ≤ 2 m Ω
Insulation resistance	≥ 5000 M Ω
Insertion loss	According to the cable
RF-leakage	N/A
VSWR	≤ 1.35 MAX@0-6GHz

MECHANICAL CHARACTERISTICS	
Force to engage and disengage	N/A
Center contact retention force	6 lbs Min
Coupling torque	15 in-lbs Min
Coupling nut retention force	60 lbs Min
Durability	≥ 500 cycles

ENVIRONMENTAL CHARACTERISTICS	
Temperature range	-55°C - +125°C
Thermal Shock	MIL-STD-202, Method 107, Cond B
Vibration	MIL-STD-202, Method 204, Cond B
Shock	MIL-STD-202, Method 213, Cond I
Climatic Class	IEC 60068 55/155/56

MATERIAL: UNLESS OTHERWISE SPECIFIED	DFTM: K. A. M.	TIMES MICROWAVE SYSTEMS
	DATE: 6/3/11	
USED ON: 0-4	CHKD: J. D. B.	TC-400-TM-RA-D 90° TNC MALE FOR LMR400 CABLE
	DATE: 6/3/11	
SCALE: N/A	APPD: J. D. B.	1 of 1 SD3190-2671 REV B
	DATE: 6/3/11	
DWG. SIZE: A	DO NOT SCALE DRAWING	CODE IDENT: 68999