

NOTES: VALID UNLESS OTHERWISE SPECIFIED

1. GENERAL:
 - 1.1 PART IS DESIGNED FOR RECEPTACLE SEALED ASSEMBLY PER MOLEX DRAWING 349671000
 - 1.2 APPLICATION SPECIFICATION SEE: AS-34894-0001
 - 1.3 PRODUCT SPECIFICATION SEE: 349670001
 - 1.4 PACKAGING SPECIFICATION PER MOLEX DRAWING: PK-31301-898
 - 1.5 PARTS MUST BE IN COMPLIANCE TO MOLEX CHEMICAL SUBSTANCES FOR PRODUCTS AND PACKAGING SPECIFICATION: QEHS-699000-300 (FOR SUPPLIERS) OR QEHS-699000-304 (INTERNAL)
 - 1.6 DATA MUST BE SUBMITTED UNDER THE MOLEX PART NUMBER TO IMDS (COMPANY ID#13255)
 - 1.7 FLAMMABILITY REQUIREMENT: PER ISO3795 OR GM3191
 - 1.6.1 BURN RATE 100 mm/MIN MAXIMUM
 - 1.6.2 MATERIAL MUST BE SELF EXTINGUISHING
2. DESIGN - MATERIALS:
 - 2.1 MATERIAL: PA66 VYDYNE 22HSP 25% REGRIND MAX BY WEIGHT
COLOR: BLACK PER 899921246
 - 2.2 VOLUME: 2596 ± 5% (ESTIMATED)
3. DESIGN - GEOMETRY:
 - 3.1 THE 3-D CAD DATA IS BASIC (WITHOUT TOLERANCE) AND MUST BE TAKEN FROM THE DATA FILE AT ITS LATEST REVISION.
 - 3.2 THE 3-D CAD DATA IS MASTER FOR THIS PART AND IS TO BE USED TO ESTABLISH DIMENSIONAL INFORMATION NOT SHOWN ON THIS DRAWING. ANY DIMENSIONS UNDERLINED INDICATE A CONFLICT WITH THE MODEL.
 - 3.3 PRODUCT DESIGN MODEL NUMBER: 349671020
 - 3.4 GEOMETRIC DIMENSIONS AND TOLERANCES PER ASME Y14.5-2009
 - 3.5 GENERAL TOLERANCES:
LINEAR: PER TITLE BLOCK
ANGULAR: X.X°±3°
 - 3.6 EDGES AND UNDIMENSIONED DETAILS PER ISO13715
 - 3.7 CORNERS SHOWN AS SHARP TO BE R 0.2 MAX.
 - 3.8 LETTERING SHALL BE 0.15 MAX RAISED IN 0.25 MAX RECESS PAD. THIS INCLUDES RECYCLING CODE, CAVITY ID, VENDOR IDENTIFICATION, AND CUSTOMER MATERIAL NUMBER.
4. DESIGN - MANUFACTURING:
 - 4.1 ALLOWABLE FLASH MAX 0.25 HIGH BY MAX 0.13 THICK.
 - 4.2 ALLOWABLE SPLIT/PARTING LINE MISMATCH 0.2 MAX.
 - 4.3 EJECTOR PIN MARKS TO BE FLUSH TO 0.25 MAX DEPRESSED. LOCATION MUST BE APPROVED BY PRODUCT ENGINEERING. EJECTOR PIN MARKS NOT PERMISSIBLE ON OR NEAR DATUM TARGET AREA.
 - 4.4 ALLOWABLE GATE VESTIGE FLUSH TO 0.25 MAX PROTRUSION. LOCATION MUST BE APPROVED BY PRODUCT ENGINEERING.
 - 4.5 VISUAL DEFECTS SHALL MEET COSMETIC STANDARD PS-45499-002 (Class B)
 - 4.6 NO EXTERNAL MOLD RELEASE AGENT ALLOWED DURING MANUFACTURING

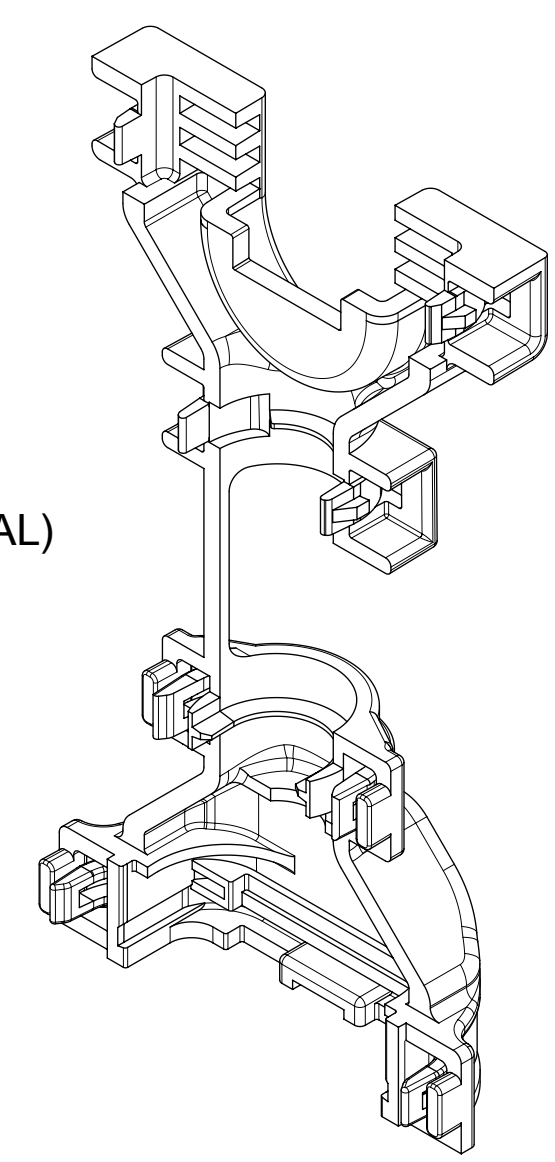

SYMBOLS	THIS DRAWING CONTAINS INFORMATION THAT IS PROPRIETARY TO MOLEX ELECTRONIC TECHNOLOGIES, LLC AND SHOULD NOT BE USED WITHOUT WRITTEN PERMISSION		
	DIMENSION UNITS	SCALE	CURRENT REV DESC: NEW PN FOR 349671010
▽ = 0	mm	4:1	
▽ = 0	GENERAL TOLERANCES (UNLESS SPECIFIED)		
▽ = 0	ANGULAR TOL ± °		
▽ = 0	4 PLACES	±	
▽ = 0	3 PLACES	±	
▽ = 0	2 PLACES	± 0.1	
▽ = 0	1 PLACE	± 0.2	
▽ = 0	0 PLACES	±	
■ = 0	DRAFT WHERE APPLICABLE MUST REMAIN WITHIN DIMENSIONS		
▽ = 0	THIRD ANGLE PROJECTION	DRAWING	SERIES
		D-SIZE	34967
		MATERIAL NUMBER	CUSTOMER
		349671020	
		DOCUMENT NUMBER	DOC TYPE DOC PART REVISION
		349671020-SD	PSD 000 A1
DOCUMENT STATUS P1		RELEASE DATE	SHEET NUMBER
2018/09/19 14:30:05			1 OF 1