

PART NO.	ENGINEERING NO.	FINISHED LENGTH
1300061579	106000A01F030	3FT [0.9M]
1300061590	106000A01F120	12FT [3.7M]
1300061600	106000A01F200	20FT [6.1M]

PART NUMBER LEGEND

106000A01F030

CABLE LENGTH
 F010 = 1 FEET
 F100 = 10 FEET
 F500 = 50 FEET

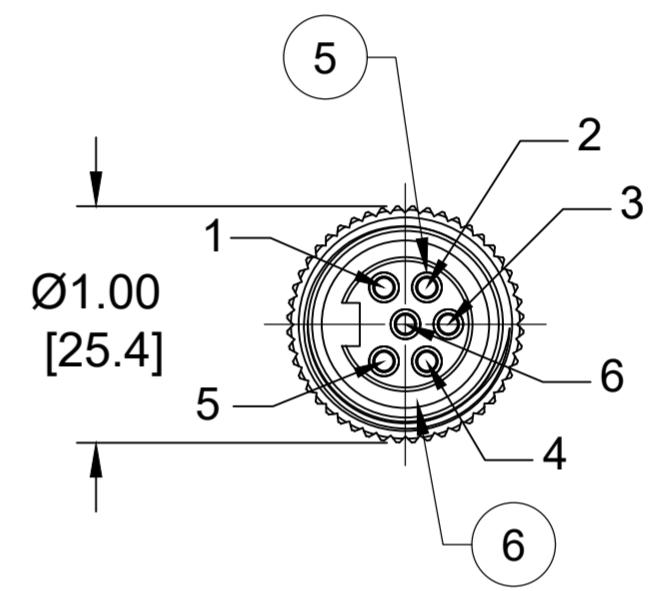
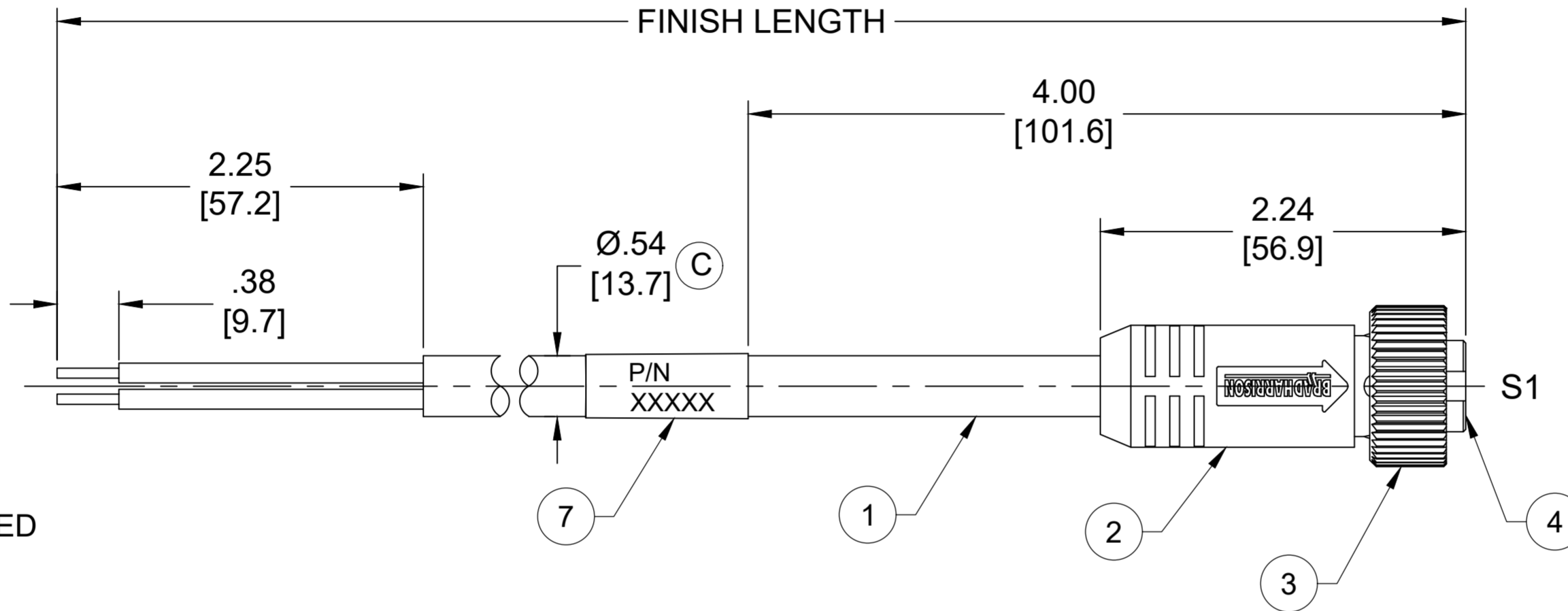
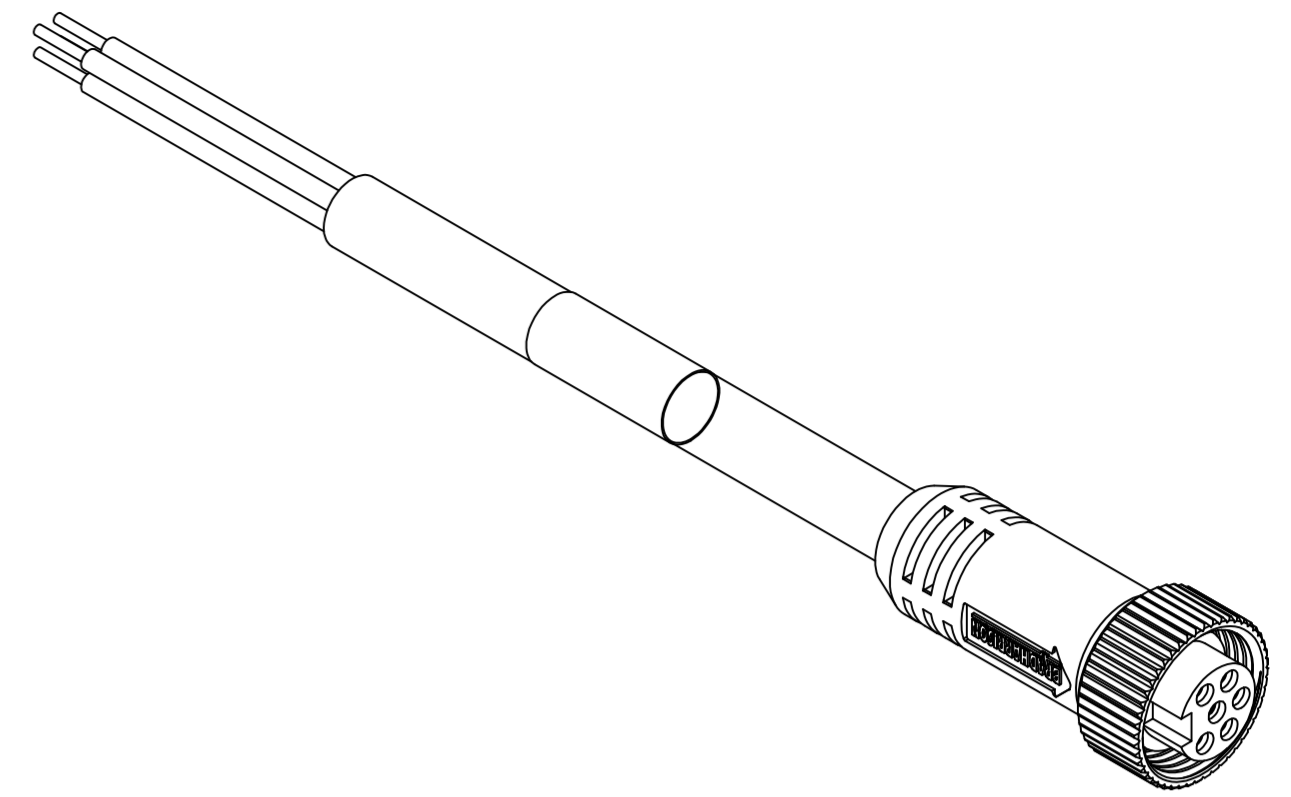

FEMALE FACE VIEW

NOTES:

- MATERIAL: AS NOTED
- FINISH: AS NOTED
- ELECTRICAL:
 VOLTAGE : 400V PER IEC 60664
 600V PER UL 2238
 CURRENT: 8A
- TEMP RATING: -20° TO +105°C
- PROTECTION: IP67 (WHEN MATED)
- COUPLING THREAD: 7/8"-16UN
- UL RECOGNIZED FILE: E152210
 CSA CERTIFIED FILE: LR6837
- ALL DIMENSIONS ARE FOR REFERENCE UNLESS TOLERANCED OR NOTED OTHERWISE

	S1
WHITE	1
RED	2
GREEN-GRD	3
ORANGE	4
BLACK	5
BLUE	6

CABLE LENGTH TOLERANCES
<.3M [1FT]: +19mm-0 [+.75in-0]
.3 - .9M [1 - 3FT]: +44.5mm-0 [+1.75in-0]
.9 - 1.8M [3 - 6FT]: +55.6mm-0 [+2.19in-0]
1.8 - 3.7M [6 - 12FT]: +88.9mm-0 [+3.50in-0]
3.7 - 7.3M [12 - 24FT]: +165.1mm-0 [+6.50in-0]
7.3-14.6M [24 - 48FT]: +317.5mm-0 [+12.50in-0]
14.6 - 30.5M [48-100FT]: +622.3mm-0 [+24.50in-0]
OVER 30M [100FT] +2% OF FINISHED LENGTH

ITEM	COMPONENT	MATERIAL	FINISH
7	WRAP LABEL	VINYL	BLACK/YELLOW
6	FRICITION RING	NYLON	WHITE
5	CONTACT SOCKET	COPPER ALLOY	GOLD OVER NICKEL
4	INSERT	TPE	YELLOW
3	COUPLING NUT	ZINC DIE CAST	BLACK-E-COAT
2	OVERMOLD	TPE	YELLOW
1	CABLE, 16 AWG, STOOV/ST	PVC	YELLOW

WIRING DIAGRAM

FUNCTIONAL SYMBOLS	THIS DRAWING CONTAINS INFORMATION THAT IS PROPRIETARY TO MOLEX ELECTRONIC TECHNOLOGIES, LLC AND SHOULD NOT BE USED WITHOUT WRITTEN PERMISSION	CURRENT REV DESC: ITEM# 2 & 4 WERE PVC. ITEM #7 WAS PLASTIC FILM. ADDED FRICTION RING, IEC VOLTAGE, PN LEGEND, CABLE DIA & TOL CHART. MODIFIED PN CHART	
	DIMENSION UNITS	SCALE	EC NO: 698916
FA=0	INCH/MM	NTS	DRWN: ABENJAMINLW 2021/05/13
FC=0	GENERAL TOLERANCES (UNLESS SPECIFIED)		CHK'D: RSTONE 2022/03/09
FD=0	mm INCH		APPR: BWOODMAN 2022/03/11
DIVISIONAL SYMBOLS	4 PLACES ±----	±----	INITIAL REVISION:
	3 PLACES ±----	±----	DRWN: TWOLDEGE 2009/07/17
	2 PLACES ±----	±----	APPR: JFMURPHY 2009/08/10
	1 PLACE ±----	±----	
	0 PLACES ±----	±----	
	ANGULAR TOL ± ---- °		
	DRAFT WHERE APPLICABLE MUST REMAIN WITHIN DIMENSIONS	THIRD ANGLE PROJECTION	DRAWING C-SIZE
			SERIES 130006
			MATERIAL NUMBER SEE CHART
			CUSTOMER GENERAL MARKET
			SHEET NUMBER 1 OF 1

molex

MINI-CHANGE CORDSET, A-SIZE
 6-POLE, FEMALE, STRAIGHT, SINGLE KEY,
 #16 AWG

PRODUCT CUSTOMER DRAWING

DOCUMENT NUMBER SD-130006-011 DOC TYPE/DOC PART REVISION PSD 001 C