

MATERIALS AND FINISHES:
 BODY, CAP, AND C'NUT ST. STEEL
 PER ASTM-582, PASSIVATED.

CRIMP TUBE, BRASS PER ASTM-B16,
 NICKEL PLATED PER QQ-N-290.

SHRINK TUBE PER MIL-DTL-23053/5
 (CLASS I & III)

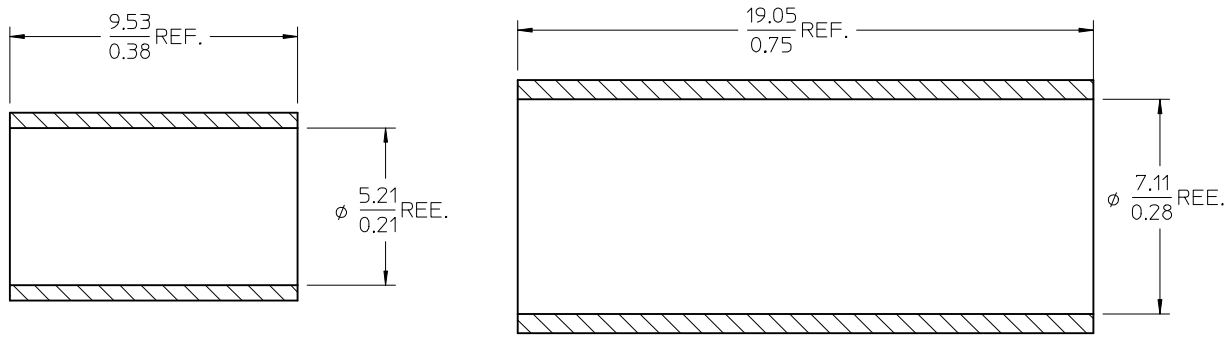
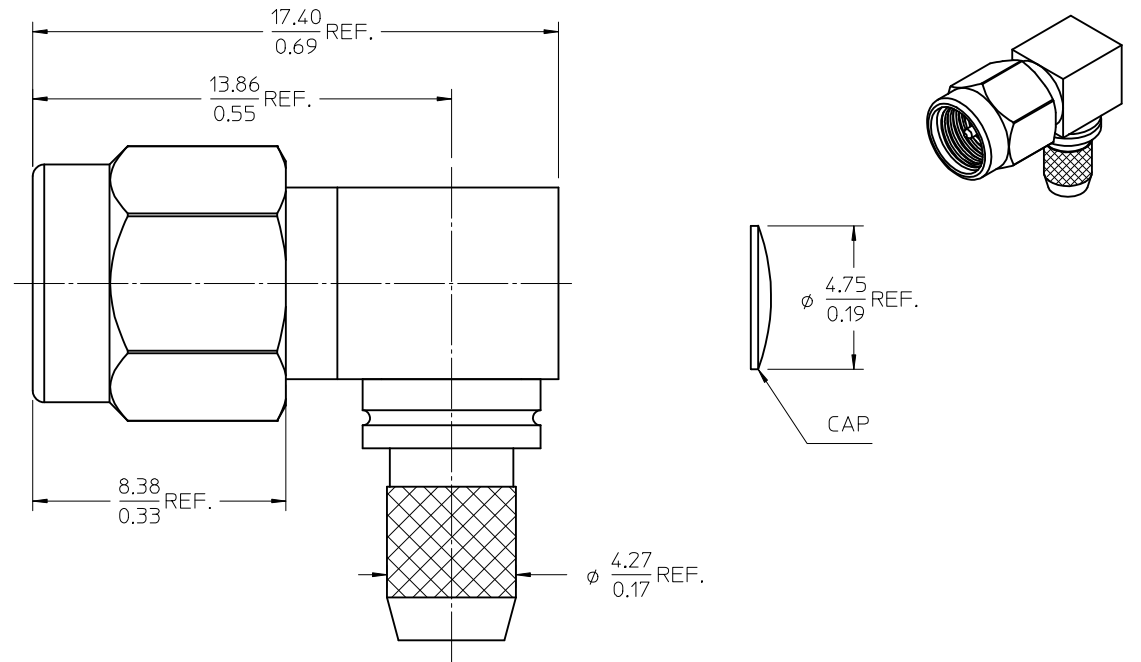

PART # 73251-0191

ES-89675-1590	CABLE ASSY INSTRUCTIONS
PS-89675-1190	ELECTRO/MECH PERFORMANCE
MIL-STD-348A, FIG. 310-1	INTERFACE
SPECIFICATION	DESCRIPTION

73251-0192	73251-0191 BY TRAY (20 CAV.)
PART NO.	PACKAGING

ADDED P/N: 73251-0192
 EC NO: URF2007-0497
 2007/06/15
 DRW: NELIN
 2007/06/21
 CHKD:
 2007/06/21
 APPR: MIHANG
 2007/06/21

QUALITY SYMBOLS $\nabla=0$ $\nabla=0$	GENERAL TOLERANCES (UNLESS SPECIFIED)		DIMENSION STYLE	SCALE	DESIGN UNITS	THIRD ANGLE PROJECTION
	mm	INCH	MM/IN		METRIC	
	4 PLACES	± ---	± ---	DRAWN BY	DATE	TITLE
	3 PLACES	± ---	± ---	MDE	1999/12/03	SMA PLUG, RA, 50 OHMS RG58, 141, 303 SMA-PC/RA
	2 PLACES	± ---	± ---	CHECKED BY	DATE	
	1 PLACE	± ---	± ---	GMH	1999/12/06	MOLEX INCORPORATED
	ANGULAR ± 2 °			APPROVED BY	DATE	
	DRAFT WHERE APPLICABLE MUST REMAIN WITHIN DIMENSIONS			GMH	1999/12/15	SD-73251-019
			MATERIAL NO.	DOCUMENT NO.		SHEET NO.
			SEE TABLE	SD-73251-019		1 OF 1
	THIS DRAWING CONTAINS INFORMATION THAT IS PROPRIETARY TO MOLEX INCORPORATED AND SHOULD NOT BE USED WITHOUT WRITTEN PERMISSION					