

4 CIRCUIT SHOWN

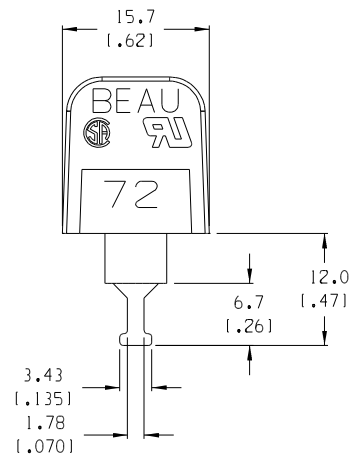
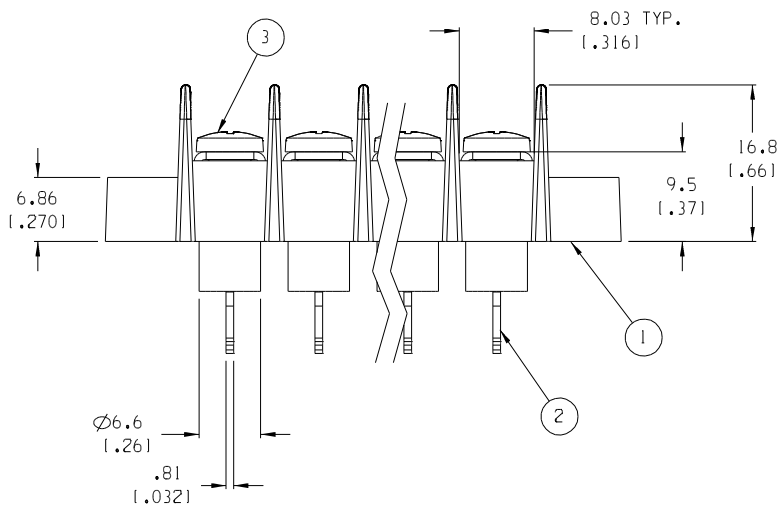

- NOTES:
1. MATERIAL: SEE TABLE
 2. FINISHES: SEE TABLE
 3. PRODUCT SPECIFICATION: NOT REQUIRED
 4. PACKAGING: NOT REQUIRED
 5. MATES WITH: NONE
 6. "XX" REFERS TO THE QUANTITY OF CIRCUITS.

ITEM	QTY.	DESCRIPTION	MATERIAL	FINISH
3	XX	SCREW, #6-32X.250, BHD, PHIL-SLOT	STEEL	ZN, CLEAR CHROMATE
2	XX	TERMINAL, TURRET	BRASS	TIN PLATE
1	1	INSULATOR, SR, MOLDED MTG.	THERMOPLASTIC	BLACK

EC NO. RELEASED DRWING: CLY CH'K: APPR: REV: A	DESCRIPTION MAJOR CRITICAL SPC S:	GENERAL TOLERANCES: (UNLESS SPECIFIED) mm INCH 4 PLACES ±.0015 3 PLACES ±.038 ±.005 2 PLACES ±.13 ±.01 1 PLACE ±.3		SCALE: 2:1 DRAWN BY & DATE: C. YORK 02-24-05	DESIGN UNITS: <input type="checkbox"/> mm <input checked="" type="checkbox"/> INCH THIRD ANGLE PROJECTION	PROJECT NO.: DIMENSIONS: <input checked="" type="checkbox"/> mm INCH <input type="checkbox"/> INCH mm <input type="checkbox"/> mm ONLY	SHEET NO. 1 OF 2	
		ANGULAR: ±2°		CHECKED BY & DATE: APPROVED BY & DATE:	TITLE: 9.53 (.375) SR BTS ASSY, INSUL. TURRET, MOLDED MTG.			
		DRAFT WHERE APPLICABLE MUST REMAIN WITHIN DIMENSIONS		CAD FILENAME: 722XX-E	MATERIAL NO.: SEE SHT. 2	DRAWING NO.: SD-38720-005	SHEET NO. 1 OF 2	
		THIS DRAWING CONTAINS INFORMATION THAT IS PROPRIETARY TO MOLEX INCORPORATED AND SHOULD NOT BE USED WITHOUT WRITTEN PERMISSION.						

NO. OF CIRC. "XX"	DIM. "A"		DIM. "B"		DIM. "C"		DIM. "D"		ASSEMBLY MATERIAL NO.
02	36.2	[1.43]	9.53	[.375]	28.58	[1.125]	21.1	[.83]	387203102
03	45.7	[1.80]	19.05	[.750]	38.10	[1.500]	30.7	[1.21]	387203103
04	55.2	[2.18]	28.58	[1.125]	47.63	[1.875]	40.2	[1.58]	387203104
05	64.8	[2.55]	38.10	[1.500]	57.15	[2.250]	49.7	[1.96]	387203105
06	74.3	[2.93]	47.63	[1.875]	66.68	[2.625]	59.2	[2.33]	387203106
07	83.8	[3.30]	57.15	[2.250]	76.20	[3.000]	68.8	[2.71]	387203107
08	93.3	[3.68]	66.68	[2.625]	85.73	[3.375]	78.3	[3.08]	387203108
09	102.9	[4.05]	76.20	[3.000]	95.25	[3.750]	87.8	[3.46]	387203109
10	112.4	[4.43]	85.73	[3.375]	104.78	[4.125]	97.3	[3.83]	387203110
11	121.9	[4.80]	95.25	[3.750]	114.30	[4.500]	106.9	[4.21]	387203111
12	131.4	[5.18]	104.78	[4.125]	123.83	[4.875]	116.4	[4.58]	387203112
13	141.0	[5.55]	114.30	[4.500]	133.35	[5.250]	125.9	[4.96]	387203113
14	150.5	[5.93]	123.83	[4.875]	142.88	[5.625]	135.4	[5.33]	387203114
15	160.0	[6.30]	133.35	[5.250]	152.40	[6.000]	145.0	[5.71]	387203115
16	169.5	[6.68]	142.88	[5.625]	161.93	[6.375]	154.5	[6.08]	387203116
17	179.1	[7.05]	152.40	[6.000]	171.45	[6.750]	164.0	[6.46]	387203117
18	188.6	[7.43]	161.93	[6.375]	180.98	[7.125]	173.5	[7.21]	387203118
19	198.1	[7.80]	171.45	[6.750]	190.50	[7.500]	192.6	[7.58]	387203119
20	207.6	[8.18]	180.98	[7.125]	200.03	[7.875]	202.1	[7.96]	387203120
21	217.2	[8.55]	190.50	[7.500]	209.55	[8.250]	211.6	[8.33]	387203121
22	226.7	[8.93]	200.03	[7.875]	219.08	[8.625]	221.2	[8.71]	387203122
23	236.2	[9.30]	209.55	[8.250]	228.60	[9.000]	230.6	[9.08]	387203123
24	245.7	[9.68]	219.08	[8.625]	238.13	[9.375]	230.7	[9.08]	387203124
25	255.3	[10.05]	228.60	[9.000]	247.65	[9.750]	240.2	[9.46]	387203125
26	264.8	[10.43]	238.13	[9.375]	257.18	[10.125]	249.7	[9.83]	387203126

PROJECT NO. -	-	-
DIMENSIONS:	SHT	REV
<input checked="" type="checkbox"/> mm <input type="checkbox"/> INCH <input type="checkbox"/> mm ONLY	REVISE ON CAD ONLY	

EC NO. SEE SHEET 1 DRWN: CH'K: APPR: - - -	DESCRIPTION MAJOR CRITICAL SPC	QUALITY SYMBOLS	GENERAL TOLERANCES: (UNLESS SPECIFIED)	SCALE: -- DESIGN UNITS: <input type="checkbox"/> mm <input checked="" type="checkbox"/> INCH	THIRD ANGLE PROJECTION	DRAWN BY & DATE C. YORK 02-24-05	TITLE: 9.53 [.375] SR BTS ASSY, INSUL. TURRET, MOLDED MTG.		
		4 PLACES: mm INCH ±.0015 ±.005	CHECKED BY & DATE	APPROVED BY & DATE	MOLEX INCORPORATED				
		3 PLACES: ±.038 ±.005 2 PLACES: ±.13 ±.01 1 PLACE: ±.3	ANGULAR: ±2°	CAD FILENAME 722XX-E	MATERIAL NO. SEE CHART	DRAWING NO. SD-38720-005	SHEET NO. 2 OF 2		
		DRAFT WHERE APPLICABLE MUST REMAIN WITHIN DIMENSIONS	THIS DRAWING CONTAINS INFORMATION THAT IS PROPRIETARY TO MOLEX INCORPORATED AND SHOULD NOT BE USED WITHOUT WRITTEN PERMISSION.				SIZE B		

