

## U7100 Pressure Transducer



- Performance standard for on and off highway engine & vehicle OEMs
- Rugged for heavy equipment and outdoor use such as HVAC refrigeration systems
- Designed specifically for high volume applications
- Stainless Steel wetted surfaces
- Low pressure ranges
- Gage, absolute, sealed gage

### DESCRIPTION

The U7100 pressure transducer from the UltraStable™ line of MEAS sets a new price performance standard for demanding engine and vehicle, and industrial applications. This transducer is suitable for measurement of liquid or gas pressure, even for difficult media such as contaminated water, steam and corrosive fluids. The transducer pressure cavity is constructed of 316L stainless steel and there are no internal O-rings or organics exposed to the pressure media. Having excellent durability, it is available with a variety of leak-proof, all metal pressure connections. The U7100 is an automotive grade pressure transducer with hermetic pressure ports and an integral electrical connector with standard pressure ranges from 0 to 15, up to 150 psi (10 Bar).

This pressure sensor exceeds the latest industrial CE requirements and includes automotive electronics requirements such as surge protection, and is overvoltage protected to 16 Vdc in both positive and reverse polarity.

### FEATURES

- Hermetic Pressure Ports
- Integral Electrical Connector
- Survives High Vibration
- ±0.25% Accuracy
- Water Resistant 1M Immersion

### APPLICATIONS

- On and Off Highway Engines and Vehicles
- HVAC Refrigeration Controls
- Compressors
- Hydraulics
- Energy and Water Management

### STANDARD RANGES

Range	psiG, psiA, psiS	Range	BarG, BarA, BarS
0 to 015	•	0 to 001	•
0 to 030	•	0 to 002	•
0 to 050	•	0 to 3.5	•
0 to 100	•	0 to 007	•
0 to 150	•	0 to 010	•

# U7100 Pressure Transducer

## PERFORMANCE SPECIFICATIONS

**Supply Voltage: 5V**

**Ambient Temperature: 25°C (unless otherwise specified)**

PARAMETERS	MIN	TYP	MAX	UNITS	NOTES
Supply Voltage	4.75	5.00	5.25	V	
Supply Current		4	10	mA	
Ratiometric Output	0.5		4.5	V	1, 5
Accuracy (combined linearity, hysteresis & repeatability)	-0.25		0.25	%Span	2
Total Error Band	-1.0		1.0	%Span	3
Compensated Temperature	-20		+85	°C	
Operating Temperature	-40		+125	°C	
Storage Temperature	-50		+125	°C	
Insulation Resistance (500Vdc)	100			MΩ	4
Reverse Voltage			16	V	
Overvoltage Protection			16	V	
Short Circuit Protected		Continuous			
Output Noise @ 1kHz		10		mV	
Response Time (10% to 90%)		1.0		ms	
Long Term Stability	-0.25		0.25	%Span/Year	

### Notes

1. Ratiometric to supply voltage.
2. Best fit straight line.
3. TEB includes all accuracy errors, thermal errors, span and zero tolerances over the compensated temperature range. See Chart A.
4. Between sensor body to any pins of connector.
5. This product can be configured for custom OEM requirements. Contact factory for different transfer functions and output clippings. See chart B.

## ENVIRONMENTAL SPECIFICATIONS

**Supply Voltage: 5V**

**Ambient Temperature: 25°C (unless otherwise specified)**

PARAMETERS	MIN	TYP	MAX	UNITS	NOTES
Humidity (@40°C)			93	%RH	
Pressure Overload			2X	Rated	6
Pressure Burst			3X	Rated	7
Pressure Cycle	10M			Cycles	
Mechanical Vibration		20g, 10 ~ 2000Hz MIL-STD-810C, Method 514.2, Curve L			
Mechanical Shock		Half-Sine, Peak: 50g, 11ms MIL-STD-202, Method 213B, Condition A			
Package Protection		IP67 (IEC60529)			

### Notes

6. The maximum pressure that can be applied without changing the transducer's performance or accuracy.
7. The maximum pressure that can be applied to a transducer without rupture of either the sensing element or transducer. See Chart B.

# U7100 Pressure Transducer

## Agency Approvals

Performance Criteria Class A: Output Change < ±1.5% FSO

IEC61000-4-2 Electrostatic Discharge Immunity: 8kV Contact / 15kV Air; Discharge Rate > 10s

IEC61000-4-3 EM Field Immunity: 100V/m, 1kHz 80% Modulation, 80 ~ 1000MHz

IEC61000-4-4 Electrical Fast Transient Immunity: Level 2, 1KV each line, Capacitance coupling

IEC61000-4-5 Surge: Level 2, 42Ω Impedance, Figure 11 (L-L 500V, L-E 1KV)

IEC61000-4-6 Conducted Immunity: Level 2, 3V/130dB, 150KHz ~ 80MHz, 2s Dwell, Clamp Injection

IEC61000-4-9 Pulsed Magnetic Field Immunity: Level 3, 100A/m, 10 Second pulse interval

IEC55022 Emission: Class B, 30dB @ 30-220MHz, 37dB @ 230-1000MHz

Pressure Port Options	Dim A (inches) [mm]	Recommended Tightening Torque (Nm)
2 = 1/4-19 BSP Male	.43 [11.0]	30
4 = 7-16-20 UNF Male SAE J514 w/ O-Ring	.36 [9.1]	19
5 = 1/4-18 NPT Male	.56 [14.2]	34
6 = 1/8-27 NPT Male	.38 [9.7]	16
P = 7/16-20UNF Female w/ Integral Valve Depressor	.54 [13.7]	19
Q = M10 x 1.0mm Male	.38 [9.6]	10

Others available upon request

Connector	Vendor	Pin Plating
Packard	<a href="http://powerandsignal.com">powerandsignal.com</a>	0.003 – 0.005 mm Sn
Sumitomo	<a href="http://sumitomokenki.com">sumitomokenki.com</a>	0.003 mm Sn over 0.0005 – 0.001 mm Cu
AMP	<a href="http://te.com">te.com</a>	0.0004 mm Au over 0.0013 mm Ni

# U7100 Pressure Transducer

## DIMENSIONS

DIMENSION ARE IN INCHES [mm]

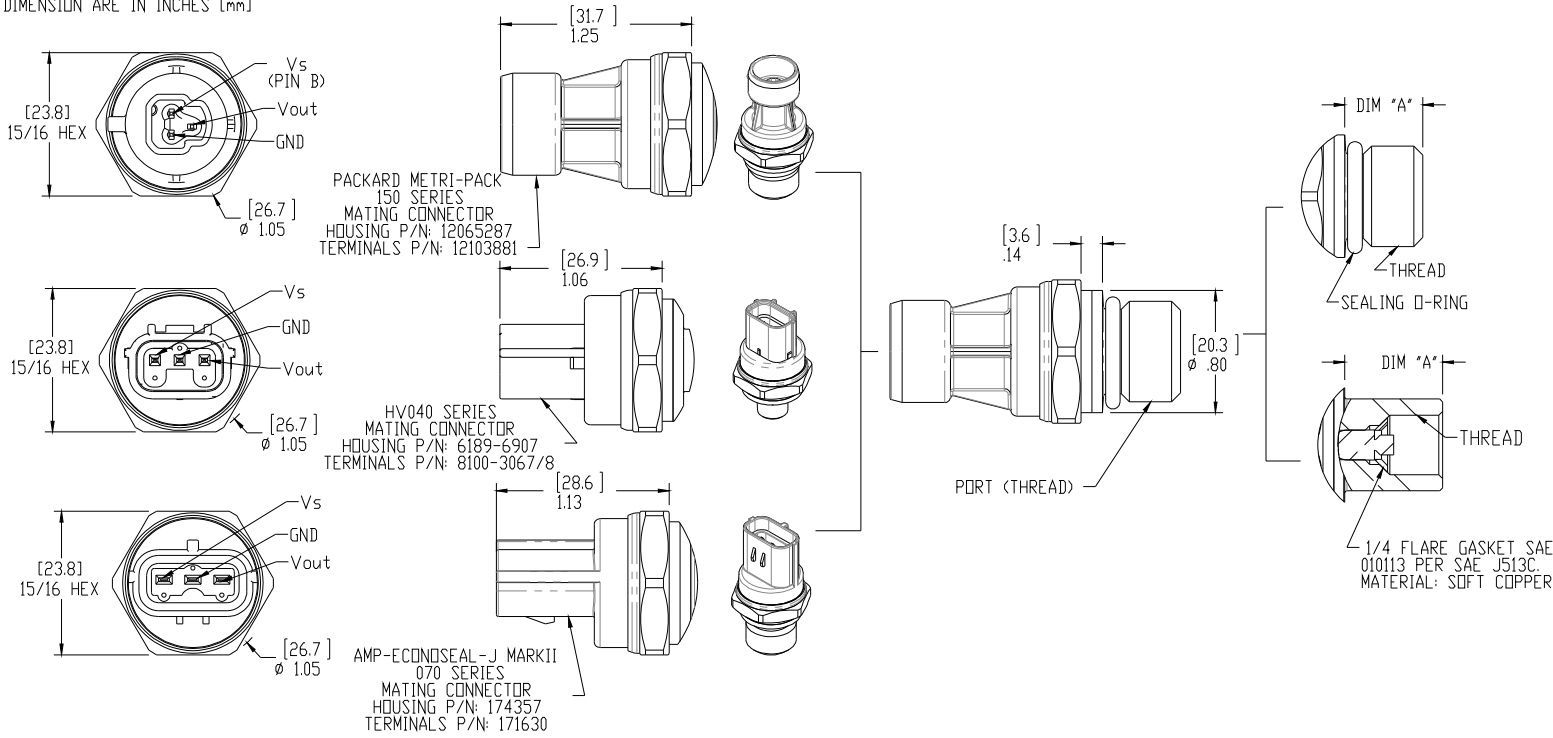

# U7100 Pressure Transducer

## CHARTS

Chart A. Pressure Transfer Function  
Supply = 5V

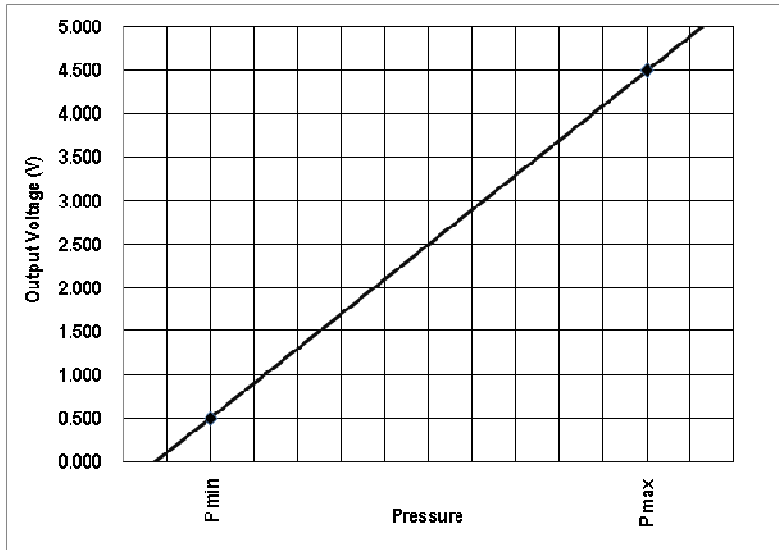
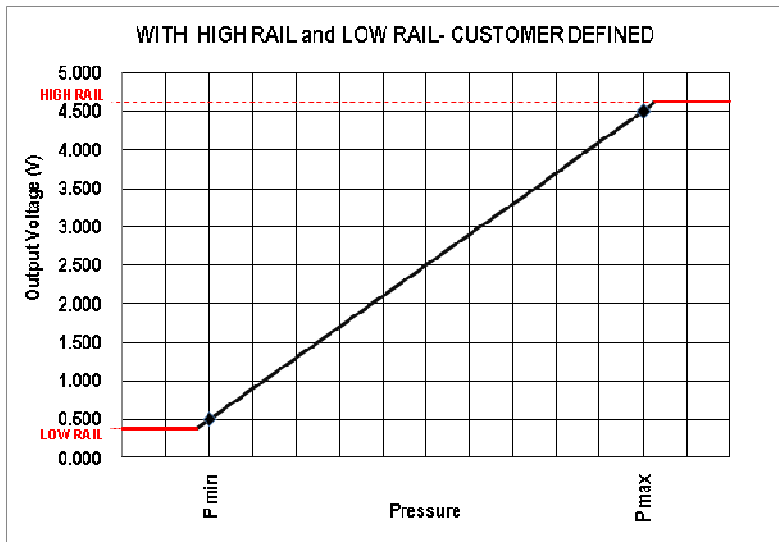

Chart B. OEM Custom Calibration  
High/Low Rail values can be adjusted by circuit



# U7100 Pressure Transducer

## ORDERING INFORMATION

U7138-100PG-2W0000

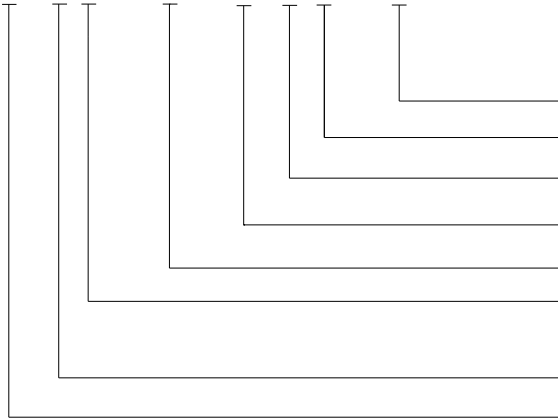

- Specials (nnnn = Custom Drawing)
- Port Material (W = 316L ST STL)
- Pressure Port (See Pressure Port Options Table)
- Type (G = Gage, A = Absolute, S = Sealed Gage)
- Pressure Range (See Pressure Range Table)
- Connection (7 = AMP Connector, 8 = Sumitomo Connector HV040, 9 = Packard Connector [Supply; PIN B])
- Output (3 = 0.5 - 4.5V)
- Model

### NORTH AMERICA

Measurement Specialties  
45738 Northport Loop West  
Fremont, CA 94538  
Tel: 1-800-767-1888  
Fax: 1-510-498-1578  
Sales: [pfg.cs.amer@meas-spec.com](mailto:pfg.cs.amer@meas-spec.com)

### EUROPE

Measurement Specialties  
(Europe), Ltd.  
26 Rue des Dames  
78340 Les Clayes-sous-Bois, France  
Tel: +33 (0) 130 79 33 00  
Fax: +33 (0) 134 81 03 59  
Sales: [pfg.cs.emea@meas-spec.com](mailto:pfg.cs.emea@meas-spec.com)

### ASIA

Measurement Specialties  
(China), Ltd.  
No. 26 Langshan Road  
Shenzhen High-Tech Park (North)  
Nanshan District, Shenzhen 518057  
China  
Tel: +86 755 3330 5088  
Fax: +86 755 3330 5099  
Sales: [pfg.cs.asia@meas-spec.com](mailto:pfg.cs.asia@meas-spec.com)

The information in this sheet has been carefully reviewed and is believed to be accurate; however, no responsibility is assumed for inaccuracies. Furthermore, this information does not convey to the purchaser of such devices any license under the patent rights to the manufacturer. Measurement Specialties, Inc. reserves the right to make changes without further notice to any product herein. Measurement Specialties, Inc. makes no warranty, representation or guarantee regarding the suitability of its product for any particular purpose, nor does Measurement Specialties, Inc. assume any liability arising out of the application or use of any product or circuit and specifically disclaims any and all liability, including without limitation consequential or incidental damages. Typical parameters can and do vary in different applications. All operating parameters must be validated for each customer application by customer's technical experts. Measurement Specialties, Inc. does not convey any license under its patent rights nor the rights of others.