

Microstick for 3V PIC24 K Series Devices

Overview

The Microstick for 3V PIC24 K Series Devices is designed to provide an easy-to-use, economical development environment for 16-bit microcontrollers. The board includes an integrated debugger/programmer, a socket for the target microcontroller chip and pins that facilitate insertion into a prototyping board for extremely flexible development.

Installing MPLAB® IDE and C Compilers

The MPLAB® Integrated Development Environment (IDE) should be installed prior to using the Microstick for 3V PIC24 K Series Devices. This board is designed to run with MPLAB X IDE Version 1.60 or later. While the MPLAB IDE provides assembler tools for development, most code examples provided for Microchip devices are written in C language and require a C compiler to be installed. Microchip's MPLAB XC16 Compiler seamlessly integrates into the MPLAB IDE. Both the MPLAB IDE and C Compiler are free and available for download at: www.microchip.com/mplabx and www.microchip.com/xc16, respectively.⁽¹⁾

Note 1: MPLAB XC16 Evaluation Version (free) – All optimization levels are enabled for 60 days, then limits to optimization, Level O1. The compiler will continue to function, but code size may increase. There are no restrictions on the use of this C compiler (see license text for details).

Running Applications

After downloading and installing the development tools, please use the following procedure to build, run and debug your software:

1. Open the MPLAB X IDE application and close any open projects.
2. Open the Microstick application project by navigating to the installation directory and selecting the "pic24f16k1402_microstick_demo.X" folder.
3. Connect the Microstick board to the development computer via a USB cable.
4. Open the project properties by selecting *File->Project Properties*.
5. Ensure the correct device is the selected device in the *Device* dropdown menu.
6. Select the Microstick from the *Hardware Tool*. It will be listed under *Microchip Starter Kits>Starter Kits (PKOB)*.
7. Build, program and run the Microstick demo application by selecting *Debug>Debug Project*.
8. Install Jumper, JP1, to enable the on-board LED for RA0 to ensure the program is running.

For more information on building, running and debugging your application, refer to the MPLAB IDE Help.

Americas

Atlanta - 678-957-9614
Boston - 774-760-0087
Chicago - 630-285-0071
Cleveland - 216-447-0464
Dallas - 972-818-7423
Detroit - 248-538-2250
Indianapolis - 317-773-8323
Los Angeles - 949-462-9523
Phoenix - 480-792-7200
Santa Clara - 408-961-6444
Toronto - 905-673-0699

Europe

Austria - Wels - 43-7242-2244-39
Denmark - Copenhagen - 45-4450-2828
France - Paris - 33-1-69-53-63-20
Germany - Munich - 49-89-627-144-0
Italy - Milan - 39-0331-742611
Netherlands - Drunen - 31-416-690399
Spain - Madrid - 34-91-708-08-90
UK - Wokingham - 44-118-921-5869

Asia/Pacific

Australia - Sydney - 61-2-9868-6733
China - Beijing - 86-10-8569-7000
China - Chengdu - 86-28-8665-5511
China - Chongqing - 86-23-8980-9588

Asia/Pacific (Continued)

China - Hangzhou - 86-571-2819-3187
China - Hong Kong SAR - 852-2943-5100
China - Nanjing - 86-25-8473-2460
China - Qingdao - 86-532-8502-7355
China - Shanghai - 86-21-5407-5533
China - Shenyang - 86-24-2334-2829
China - Shenzhen - 86-755-8864-2200
China - Wuhan - 86-27-5980-5300
China - Xiamen - 86-592-2388138
China - Xian - 86-29-8833-7252
China - Zhuhai - 86-756-3210040
India - Bangalore - 91-80-3090-4444
India - New Delhi - 91-11-4160-8631
India - Pune - 91-20-2566-1512
Japan - Osaka - 81-6-6152-7160
Japan - Tokyo - 81-3-6880-3770
Korea - Daegu - 82-53-744-4301
Korea - Seoul - 82-2-554-7200
Malaysia - Kuala Lumpur - 60-3-6201-9857
Malaysia - Penang - 60-4-227-8870
Philippines - Manila - 63-2-634-9065
Singapore - 65-6334-8870
Taiwan - Hsin Chu - 886-3-5778-366
Taiwan - Kaohsiung - 886-7-213-7828
Taiwan - Taipei - 886-2-2508-8600
Thailand - Bangkok - 66-2-694-1351

2/21/13



Microchip Technology Inc. • 2355 West Chandler Blvd. • Chandler, AZ 85224-6199

www.microchip.com

The Microchip name and logo, the Microchip logo, and MPLAB are registered trademarks of Microchip Technology Incorporated in the U.S.A. and other countries. REAL ICE and PICkit are trademarks of Microchip Technology Incorporated in the U.S.A. and other countries. All other trademarks mentioned herein are property of their respective companies. © 2013, Microchip Technology Incorporated, Printed in the U.S.A. All Rights Reserved. 3/13

Developing Applications

Microstick for 3V PIC24 K Series Devices only implements circuitry for low-voltage ICSP™ programming. To enable low-voltage ICSP programming, it is important to always configure the microcontroller to enable $\overline{\text{MCLR}}$ pin function, rather than RA5 general purpose, input pin function.

The following assembly language directive enables the $\overline{\text{MCLR}}$ pin function in the device Configuration bits:

```
; MCLR Pin Enable bit (RA5 input disabled; MCLR enabled)
config __FPOR, MCLRE_ON
```

In XC16, the same thing is accomplished with this code:

```
// MCLR Pin Enable bit (RA5 input disabled; MCLR enabled)
FPOR(MCLRE_ON)
```

Warning: Always program the microcontroller with $\overline{\text{MCLR}}$ pin functionality enabled so that the Microstick for 3V PIC24 K Series Devices can be used to program/debug the chip in the future.

If the microcontroller is programmed with $\overline{\text{MCLR}}$ pin function disabled (RA5 input is enabled), the Microstick will no longer program or debug firmware on the microcontroller, because Microstick does not have circuitry to use high-voltage ICSP entry. REAL ICE™, MPLAB ICD 3 and PICKit™ 3 are examples of high-voltage ICSP tools that can be used to recover the part.

The slide switch, labeled S3 on the PCB, is used to select which pair of PGECx/PGEDx pins to use for In-Circuit Serial Programming™ (ICSP™). When moved towards the PDIP socket, the Microstick is set for using PGEC3/PGED3. When moved towards the USB connector, the Microstick is configured for PGEC1/PGED1.

To allow for debugging to work in MPLAB, the device's Configuration bits must be set up to indicate which PGECx/PGEDx pins are actually being used in the circuit. For example, in assembly language, you may need directives such as this:

```
.include "p24Fxxxx.inc"
; ICD Pin Placement Select (EMUC/EMUD share PGC3/PGD3)
config __FICD, ICS_PGx3
```

In XC16, the same thing can be accomplished with this code:

```
#include <p24Fxxxx.h>
// ICD Pin Placement Select (EMUC/EMUD share PGC3/PGD3)
_FICD(ICS_PGx3)
```

An XC16 firmware source code example for blinking the Microstick's LED is provided on the Microchip web site (see <http://www.microchip.com/microstick>).

Hardware Design

The Microstick for 3V PIC24 K Series Devices is USB bus powered. An on-board MCP1727 LDO regulator provides +3.3 VDC output from the USB bus power. Turning power on/off to the target application is controlled by the MPLAB IDE via the FPF2102 load switch. The FPF2102 load switch automatically shuts down power to the target if the current exceeds a trip point of 200 mA to 400 mA. This may help protect the host PC USB port from accidental shorting of power supply pins in the target application circuit.

The Microstick may be plugged into a prototyping board to develop external application circuitry with the PIC® MCU. On the bottom side of the board, three rows of pins are provided, labeled P1, P2 and P3. Normally, the Skinny PDIP (SPDIP) layout (300 mils) should be used by populating rows, P1 and P2. Optionally, rows, P1 and P3, may be populated instead to provide a wide PDIP layout (600 mils).

Introducing the Microstick for 3V PIC24 K Series Devices

Application Hardware

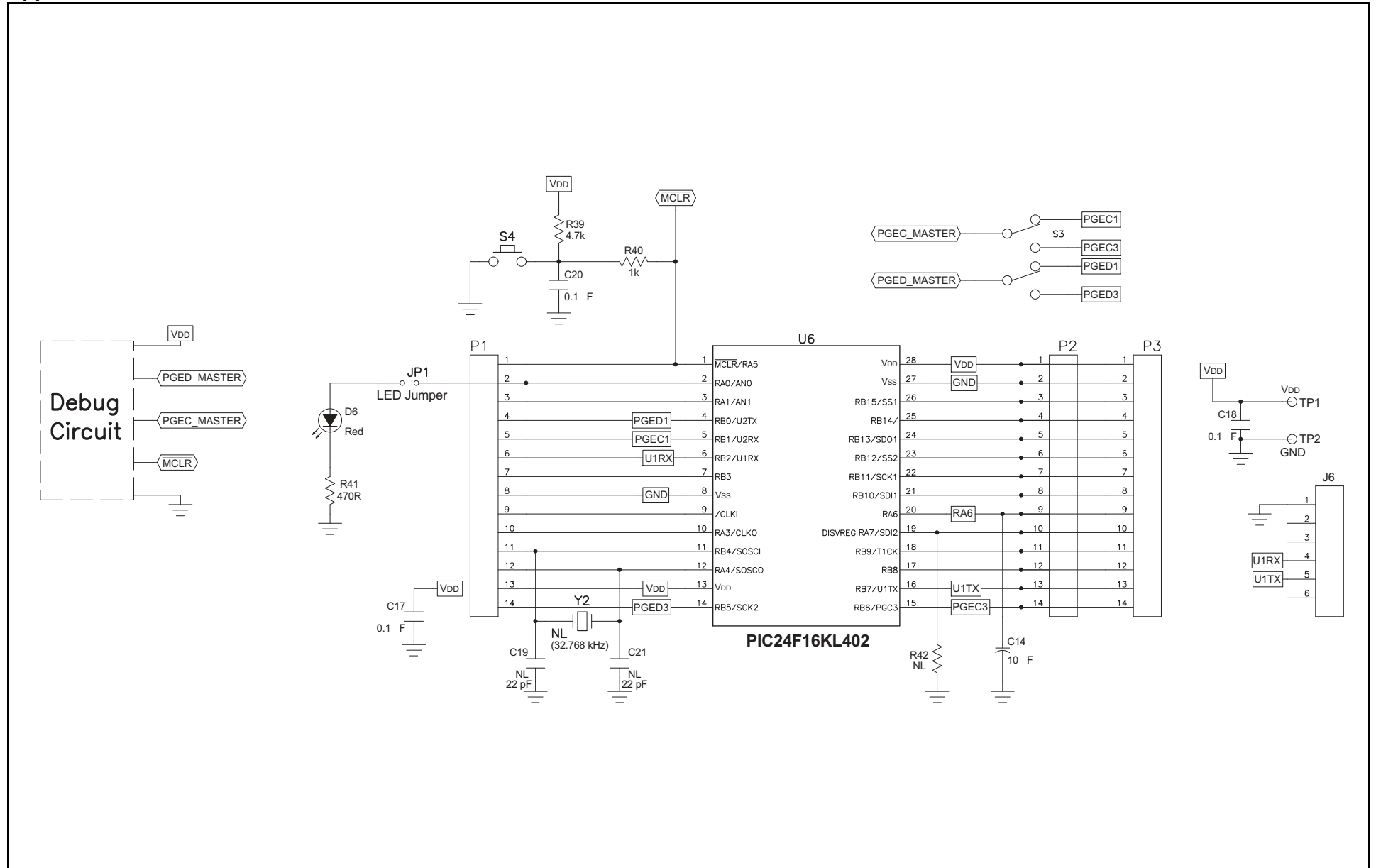

Introducing the Microstick for 3V PIC24 K Series Devices

Debugger Hardware

