

PART NO.	ENG. NO.	PACKAGING
02-06-1131	1855-(P901)	18550000-PK
02-06-1132	1855-(P901)L	PK-1190-003
02-06-5130	1855-(P550)	18550000-PK
02-06-5135	1855-(P550)L	PK-1190-003
02-06-1141	1855-1(P901)	18550000-PK
NOT TOOLED	1855-1(P901)L	PK-1190-003

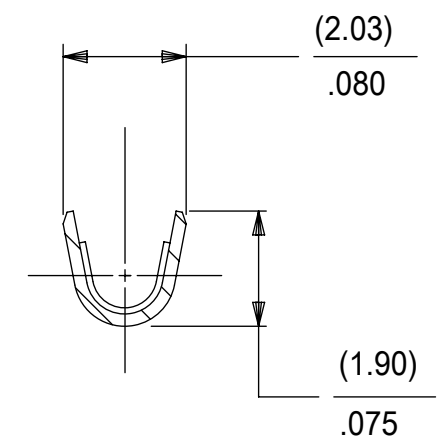
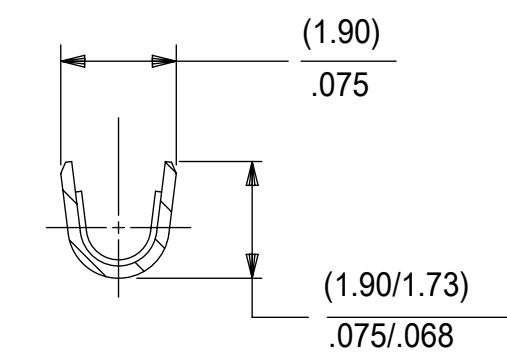
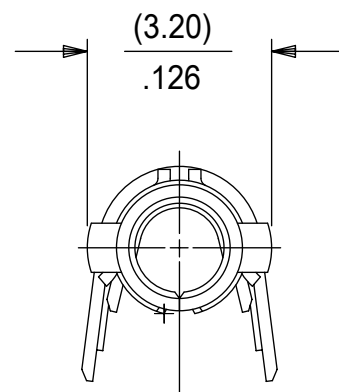
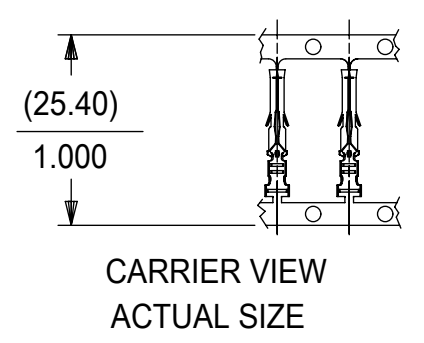

LEGEND

1855-*(****)*

BLANK=WITH LOCKING TABS
1=WITHOUT LOCKING TABS

P=PREPLATE
BLANK=POSTPLATE

FORM
BLANK=CHAIN
1=CHAIN WITH INTERLEAF
PAPER ON REEL.
L=LOOSE
FINISH CODE

NOTES:

- MATERIAL: BRASS
- FINISHES:
 - 901 HOT TIN DIP (.00051)/.000020 MIN.
 - 228 SELECT GOLD PLATE (.00075/.000030 MIN. IN CONTACT AREA, SELECT TIN (.00250)/.000100 MIN. IN CRIMP AREA OVER (.00125)/.000050 MIN. NICKEL OVERALL
 - 561 SELECT GOLD PLATE (.00076)/.000030 MIN. IN CONTACT AREA, (.00127)/.000050 MIN. NICKEL OVERALL.
 - 550 SELECT GOLD PLATE (.00038)/.000015 MIN. IN CONTACT AREA, OVER (.00076)/.000030 MIN. NICKEL OVERALL WITH (.00025)/.000010 MAX. GOLD FLASH OVERALL.
- PRODUCT SPECIFICATION: PS-02-06
- PACKAGE INFORMATION: SEE CHART
- TERMINAL FOR USE WITH (1.57)/.062 DIA. SERIES HOUSINGS AND WILL ACCEPT 24 THRU 30 AWG WIRE WITH (1.02/2.29)/.040/.090 INSULATION DIAMETER.
- PARTS CONFORM TO CLASS B REQUIREMENTS OF COSMETIC SPECIFICATION PS-45499-002.
- MARKING MAY VARY ON PARTS, CONSULT FACTORY.
- TIP GEOMETRY IS TOOL DEPENDENT. EITHER GEOMETRY IS ACCEPTABLE.

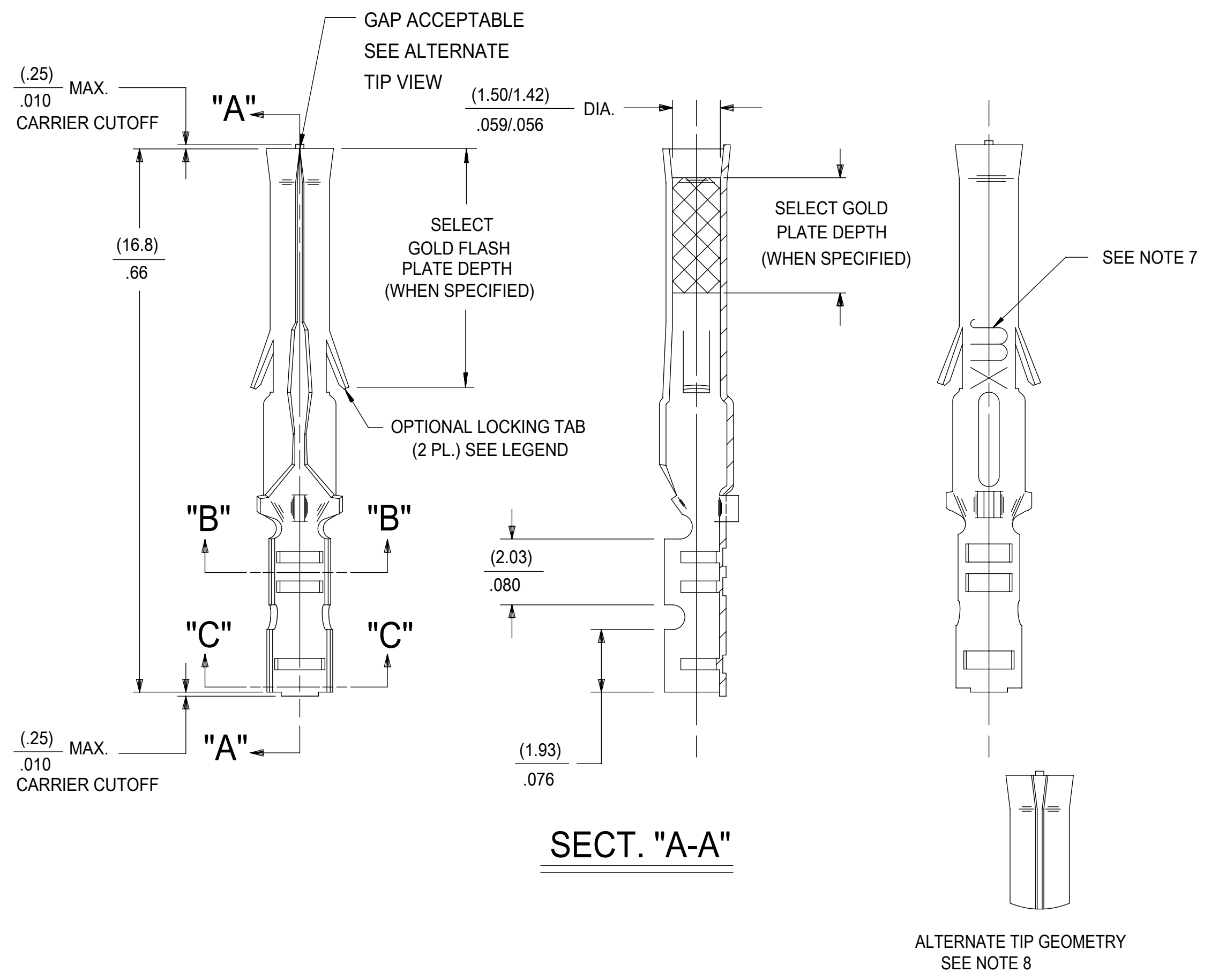

THIS DRAWING CONTAINS INFORMATION THAT IS PROPRIETARY TO MOLEX ELECTRONIC TECHNOLOGIES, LLC AND SHOULD NOT BE USED WITHOUT WRITTEN PERMISSION									
DIMENSION UNITS		SCALE		CURRENT REV DESC: REMOVE 46999-0998					
MM/IN		NTS							
GENERAL TOLERANCES (UNLESS SPECIFIED)				EC NO: 742179		2023/03/01		CRIMP TERMINAL, FEMALE (1.57)/.062 DIA., BRASS FOR 24 THRU 30 GA. WIRE	
				DRWN: MKIPPER		2023/03/13			
4 PLACES ±				CHK'D: MKIPPER		2023/03/13		PRODUCT CUSTOMER DRAWING DOCUMENT NUMBER: SD-1855-X DOC TYPE: PSD DOC PART: 001 REVISION: AP6	
3 PLACES ±				APPR: FSMITH					
2 PLACES ± 0.25				INITIAL REVISION:				MATERIAL NUMBER: SEE TABLE CUSTOMER: GENERAL MARKET SHEET NUMBER: 1 OF 1	
1 PLACE ± 0.35				DRWN: GEP		1987/09/17			
0 PLACES ±				APPR: RAS		1987/09/17			
ANGULAR TOL ± 0.5 °				THIRD ANGLE PROJECTION		DRAWING: C-SIZE		SERIES: 1855	
DRAFT WHERE APPLICABLE MUST REMAIN WITHIN DIMENSIONS									

DOCUMENT STATUS	P1	RELEASE DATE	2023/03/13	23:35:27
-----------------	----	--------------	------------	----------