

**RIGHT ANGLE PLUG SOLDER TYPE**

**R125.153.000**

**CABLE .085**

Series : SMA

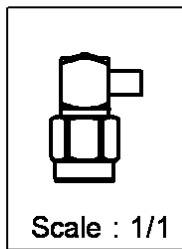
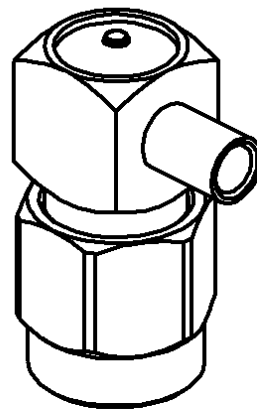
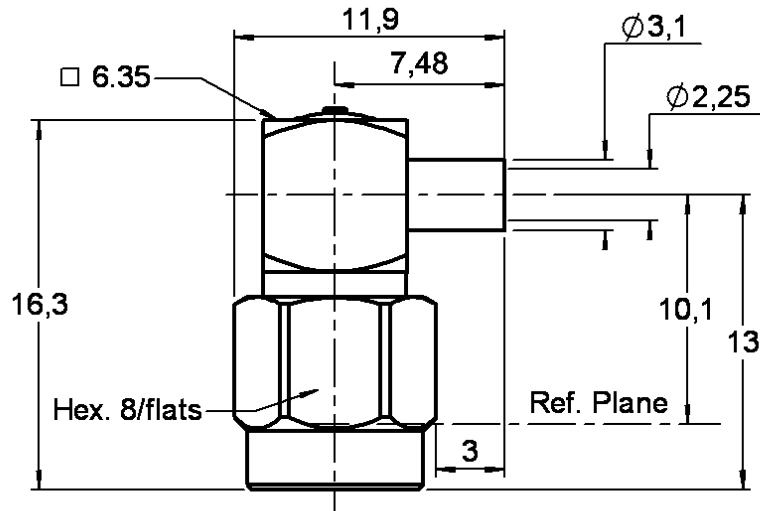

CECC 22111-803-03

All dimensions are in mm.



COMPONENTS	MATERIALS	PLATINGS (µm)
BODY	STAINLESS STEEL	GOLD 0.5 OVER NICKEL 2
CENTER CONTACT	BRASS	GOLD 1.3 OVER NICKEL 2
OUTER CONTACT	-	-
INSULATOR	PTFE	-
GASKET	SILICONE RUBBER	-
OTHERS PARTS	STAINLESS STEEL	GOLD 0.5 OVER NICKEL 2
-	-	-
-	-	-

Issue : 0044 U

In the effort to improve our products, we reserve the right to make changes judged to be necessary.



**RIGHT ANGLE PLUG SOLDER TYPE**

**R125.153.000**

**CABLE .085**

Series : SMA

**PACKAGING**

Standard	Unit	Other
<b>100</b>	<b>'W' option</b>	<b>Contact us</b>

**SPECIFICATION**

**ELECTRICAL CHARACTERISTICS**

Impedance		<b>50</b> Ω
Frequency		<b>0-12.4</b> GHz
VSWR	<b>1.10 +</b>	<b>0.010</b> x F(GHz) Maxi
Insertion loss		<b>0.05</b> √F(GHz) dB Maxi
RF leakage	- (	<b>90</b> - F(GHz)) dB Maxi
Voltage rating		<b>335</b> Veff Maxi
Dielectric withstanding voltage		<b>750</b> Veff mini
Insulation resistance		<b>5000</b> MΩ mini

**CABLE ASSEMBLY**

Stripping	a	b	c	d	e	f
mm	3.17	0.00	0.00	0.00	0.00	0.00

Assembly instruction : **Solder 02**

Recommended cable(s)  
KS 1  
RG 405

Cable retention  
- pull off **130** N mini  
- torque **NA** N.cm

**MECHANICAL CHARACTERISTICS**

Center contact retention		
Axial force – Mating end	<b>27</b>	N mini
Axial force – Opposite end	<b>27</b>	N mini
Torque	<b>2.8</b>	N.cm mini

Recommended torque		
Mating	<b>100</b>	N.cm
Panel nut	<b>NA</b>	N.cm
Clamp nut	<b>NA</b>	N.cm
A/F clamp nut	<b>0.000</b>	mm

Mating life	<b>500</b>	Cycles mini
Weight	<b>3.700</b>	g

**TOOLING**

Part Number	Description	Hexagon
.	.	.
R282.120.010	SMA TOOLBOX	
R282.051.000	STRIPPING TOOL	
R282.063.000	POINTER GAUGE	
R282.740.000	SOLDERING MOUNTING	
R282.744.200	SOLDERING POSITIONER FOR RIGHT ANGLE SMA	

**OTHERS CHARACTERISTICS**

-

**ENVIRONMENTAL**

Operating temperature	<b>-65/+105</b>	° C
Hermetic seal	<b>NA</b>	Atm.cm3/s
Panel leakage	<b>NA</b>	

Issue : 0044 U

In the effort to improve our products, we reserve the right to make changes judged to be necessary.

