

mat'l. code		surface ASME Y14.5		tolerance ASME Y14.5		projection		product family	
ltr		ecn no	dr	date	tolerances unless otherwise specified		MM		SCA-2
B	V00523	EPK	3/28/00		angles	.X ± .3	title		SCA-2 & FIBER CHANNEL
C	V02706	LSS	10/23/00		0°±2'	.XX ± .13	40 POS. RECEPT. ASS'Y EXT. HT.		
D	V10902	LSS	02/21/01			.XXX ± .051	scale 2:1		sheet 1 of 4
E	V11185	JWS	04/12/01	dr	D. INGRAM	9/28/96	FCI		
F	S04-0090	GLL	04/30/04	engr	JULIA WANG	5/25/07	72443		A4
G	S04-0250	GLL	11/22/04	chr	GARY HSIEH	5/25/07	type		Product Customer Drawing
H	pg07-0224	JW	05/25/07	appd	JOSEPH HSIA	5/25/07			
sheet index	revision sheet	H	H	H	H				
		1	2	3	4				

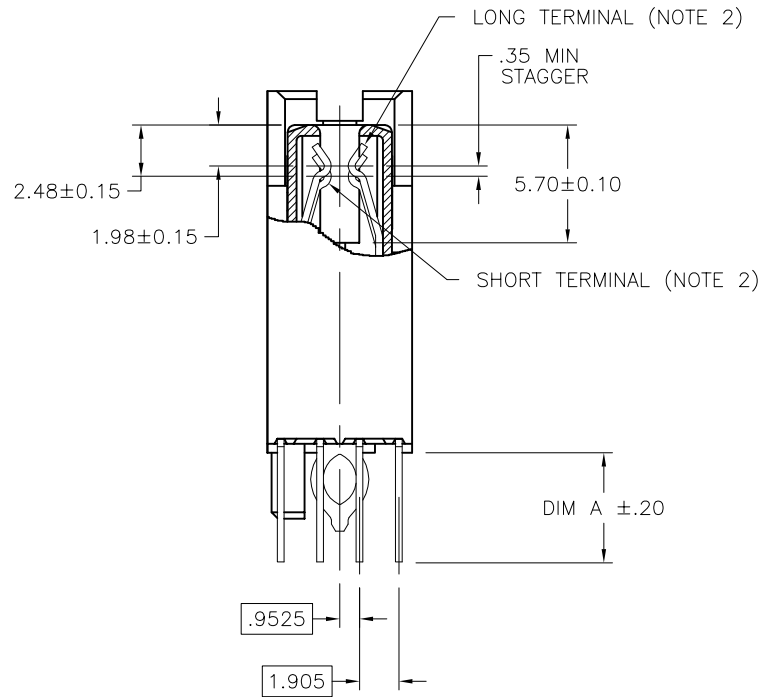

SECTION A-A

mat'l. code		surface ASME Y14.5		tolerance ASME Y14.5		projection		product family SCA-2	
ltr	ecn no	dr	date	tolerances unless otherwise specified		MM		title	
H				angles	.X±.3	scale 3:1		SCA-2 & FIBER CHANNEL	
				linear	.XX±.13			40 POS. RECEPT. ASS'Y EXT. HT.	
				0°±2'	.XXX±.051			dwg no sheet 2 of size	
				dr	D. INGRAM 9/28/96			72443 A4	
				engr	JULIA WANG 5/25/07			type Product Customer Drawing	
				chr	GARY HSIEH 5/25/07				
				appd	JOSEPH HSIA 5/25/07				
sheet index	revision sheet								

PRODUCT NO. SEE NOTE 7	DIM A	POLARIZATION PEG	PLATING	RECOMMENDED P.C. BOARD THICKNESS	PRODUCT NO. SEE NOTE 7	PLATING	PRODUCT NO. SEE NOTE 12	PLATING	PRODUCT NO. SEE NOTE 12	PLATING
72443-001	3.79	YES	NOTE 4	2.36mm (0.093") AND 3.18mm (0.125")	72443-101	NOTE 6	72443-001LF	NOTE 9	72443-201LF	NOTE 8
-001S					-101S		-202LF			
-002	-102	-203LF								
-002S	-102S	-204LF								
-003	-103									
-003S	-103S									
-004	-104									
72443-004S	4.60	NO			72443-104S					

NOTES :

- ① TRUE POSITION NOTES APPLY AT TERMINAL TIP.
- ② CONTACTS IN POSITIONS 1 THRU 20, 24, 25, 27, 28, 30, 31, 33, AND 34 ARE SHORT TERMINALS. CONTACTS IN POSITIONS 21, 22, 23, 26, 29, 32, AND 35 THRU 40 ARE LONG TERMINALS.
- ③ RAW MATERIALS:
HOUSING: HTN, UL94V-0, COLOR: BLACK
CONTACTS: PHOSPHOR-BRONZE
- ④ CONTACT PLATING: 30u" (0.76um) MIN. GXT PLATING OVER 50u" (1.27um) NICKLE MIN. UNDERPLATE IN CONTACT AREA. 20u" (0.5um) MIN-60u" (1.5um) MAX TIN-LEAD PLATING OVER 50u" (1.27um) MIN NICKEL UNDERPLATE IN P.C. BOARD LEG AREA. 50u" (1.27um) MIN. NICKEL UNDERPLATE OVER REMAINING AREA.
- ⑤ DIMENSIONS DO NOT APPLY TO CONNECTOR STYLES WITHOUT POLARIZATION PEG. (SEE CHART)
- ⑥ CONTACT PLATING: 30u" (0.76um) MIN. GOLD PLATING OVER 50u" (1.27um) NICKLE MIN. UNDERPLATE IN CONTACT AREA. 20u" (0.5um) MIN-60u" (1.5um) MAX TIN-LEAD PLATING OVER 50u" (1.27um) MIN. NICKEL UNDERPLATE IN P.C. BOARD LEG AREA. 50u" (1.27um) MIN. NICKEL UNDERPLATE OVER REMAINING AREA.
- ⑦ PART NUMBERS WITH AN "S" SUFFIX ARE MANUFACTURED WITH A BRIGHT TIN-LEAD FINISH ON THE TERMINAL TAIL SECTION. PART NUMBERS WITHOUT AN END SUFFIX ARE MANUFACTURED WITH MATTE TIN-LEAD FINISH OR MATTE TIN FINISH.
- ⑧ CONTACT PLATING: 30u" (0.76um) GOLD PLATING OVER 50u" (1.27um) NICKLE UNDERPLATE IN CONTACT AREA. 20u" (0.5um) - 60u" (1.5um) TIN PLATING OVER 50u" (1.27um) - 100u" (2.54um) NICKEL UNDERPLATE IN P.C. BOARD LEG AREA. 50u" (1.27um) NICKEL UNDERPLATE OVER REMAINING AREA.
- ⑨ CONTACT PLATING: 30u" (0.76um) GXT PLATING OVER 50u" (1.27um) NICKLE UNDERPLATE IN CONTACT AREA. 20u" (0.5um) - 60u" (1.5um) TIN PLATING OVER 50u" (1.27um) - 100u" (2.54um) NICKEL UNDERPLATE IN P.C. BOARD LEG AREA. 50u" (1.27um) NICKEL UNDERPLATE OVER REMAINING AREA.
- ⑩ THE HOUSING WILL WITHSTAND EXPOSURE TO 260° C PEAK TEMPERATURE FOR 10 SECONDS IN A CONVECTION, INFRA RED VAPOR PHASE REFLOW OVEN.

SEE NOTE 6 SEE NOTE 9 SEE NOTE 8

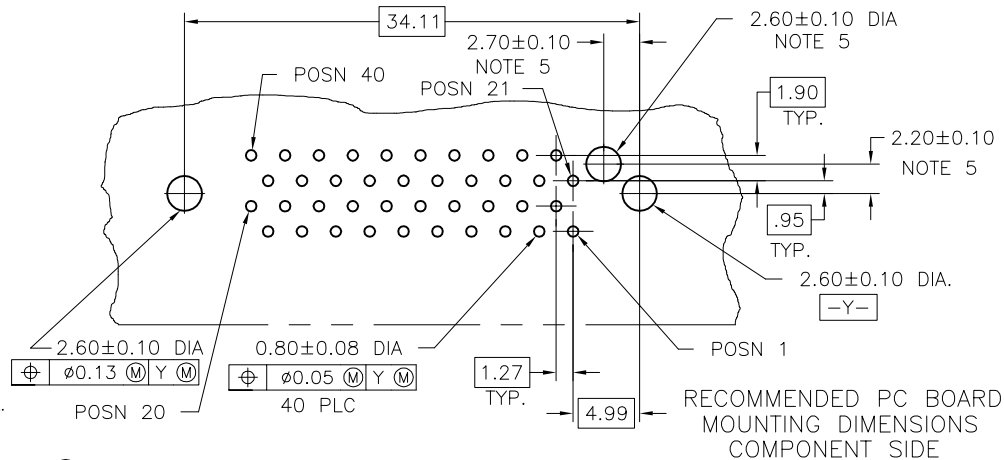

- ⑪ THIS PRODUCT MEETS EUROPEAN UNION DIRECTIVES AND OTHER COUNTRY REGULATIONS AS DESCRIBED IN GS-22-008.
- ⑫ PART NUMBERS ENDING IN "LF" MEANS FOR NOTE 11 LEAD FREE IDENTIFICATION. P/N XXXXX-2XXLF IS EQUIVALENT TO PREVIOUS P/N XXXXX-2XX

mat'l. code		surface ASME Y14.5		tolerance ASME Y14.5		projection		product family SCA-2			
ltr	ecn	no	dr	date		tolerances unless otherwise specified		title			
H						angles .X±.3		SCA-2 & FIBER CHANNEL			
						.XX±.13		40 POS. RECEPT. ASS'Y EXT. HT.			
						0°±2' .XXX±.051		scale 2:1			
			dr	D. INGRAM	9/28/96	FCI		sheet 3 of 4			
			engr	JULIA WANG	5/25/07			72443		A4	
			chr	GARY HSIEH	5/25/07			Product Customer Drawing			
			appd	JOSEPH HSIA	5/25/07						
sheet index	revision sheet										

SEE NOTE 12	DIM A	PEG	PLATING	BOARD THICKNESS	REMARK
72443-205LF	3.79	YES	NOTE 8	2.36mm (0.093") AND 3.18mm (0.125")	NOTE 14
-206LF	3.79	NO			

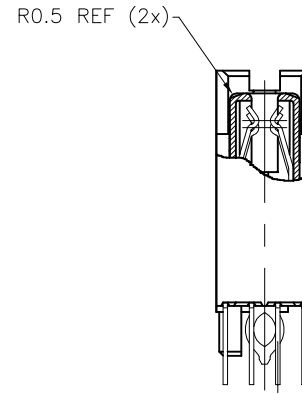
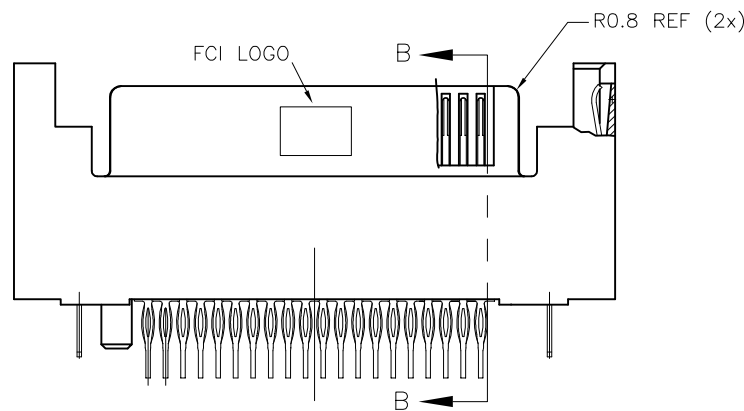
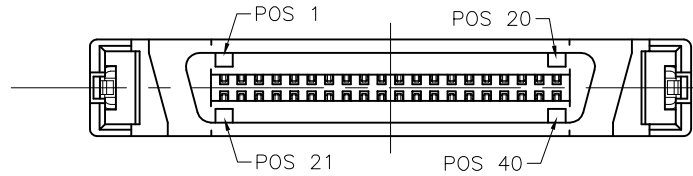

ALL OTHER DIMENSIONS, REFER TO 72443-201LF (SHEET 1 - 3)

SECTION B-B

NOTES :

14 WITH CUSTOMISED RADIUS ADDED

mat'l. code		surface ASME Y14.5		tolerance ASME Y14.5		projection		product family SCA-2	
ltr	ecn no	dr	date	tolerances unless otherwise specified		MM		title	
H				angles	.X±.3	← MM →		SCA-2 & FIBER CHANNEL	
				0°±2'	.XX±.13	scale 2:1		40 POS. RECEPT. ASS'Y EXT. HT.	
				dr	D. INGRAM	9/28/96		dwg no sheet 4 of 4 size	
				engr	JULIA WANG	5/25/07		72443 A4	
				chr	GARY HSIEH	5/25/07		type Product Customer Drawing	
				appd	JOSEPH HSIA	5/25/07			
sheet index	revision sheet								