

Tiny Package, High Performance, Diode Embedded White LED Driver

General Description

The RT9285 is a high frequency asynchronous boost converter with internal diode, which can support 2 to 5 White LEDs for backlighting and OLED power supply. The Internal soft start function can reduce the inrush current. The device operates with 1MHz fixed switching frequency to allow small external components and to simplify possible EMI problems. The device comes with 20V over voltage protection to allow inexpensive and small-output capacitors with lower voltage rating. The LED current is initially set with the external sense resistor R_{SET} , and the feedback voltage is 250mV. Tiny package type TSOT-23-6 and WDFN-8L 2x2 packages provide the best solution for PCB space saving and total BOM cost.

Ordering Information

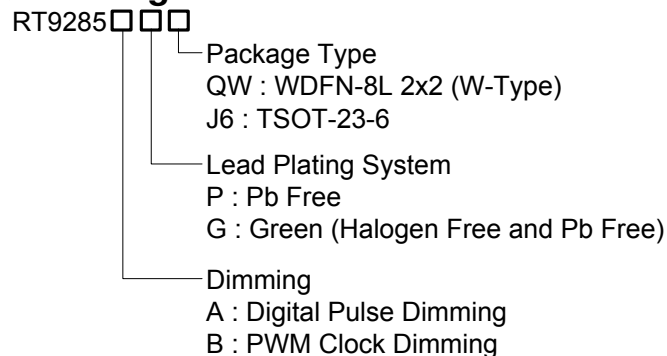

Note :

Richtek products are :

- ▶ RoHS compliant and compatible with the current requirements of IPC/JEDEC J-STD-020.
- ▶ Suitable for use in SnPb or Pb-free soldering processes.

Features

- V_{IN} Operating Range : 2.7V to 5.5V
- Up to 85% Efficiency
- 22V Internal Power N-MOSFET
- 1MHz Switching Frequency
- Built-in Diode
- Digital Dimming with Zero-Inrush
- Input UVLO Protection
- Output Over Voltage Protection
- Internal Soft Start and Compensation
- TSOT-23-6 and 8-Lead WDFN Package
- RoHS Compliant and 100% Lead (Pb)-Free

Applications

- Cellular Phones
- Digital Cameras
- PDAs and Smart Phones
- Portable Instruments
- MP3 Player
- OLED Power

Pin Configurations

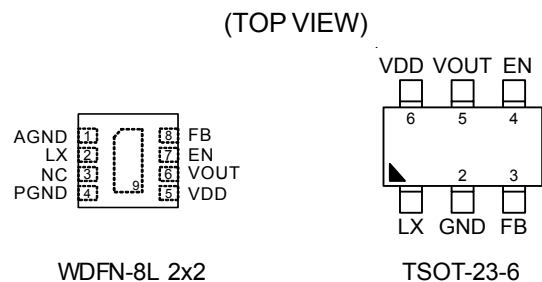

Simplified Application Circuit

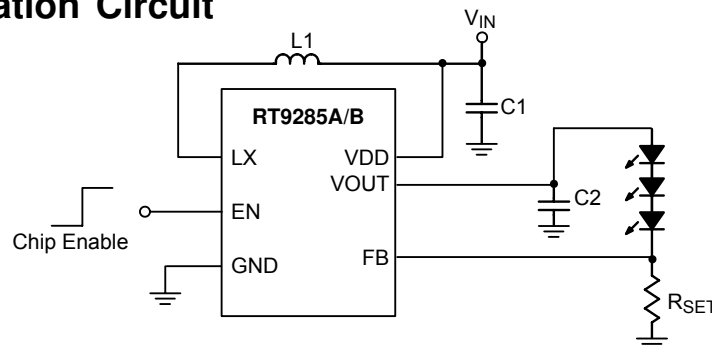

Marking Information

RT9285APQW

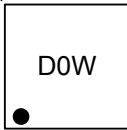

D0 : Product Code
W : Date Code

RT9285BPQW

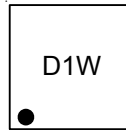

D1 : Product Code
W : Date Code

RT9285AGQW

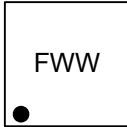

FW : Product Code
W : Date Code

RT9285BGQW

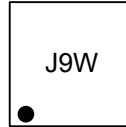

J9 : Product Code
W : Date Code

RT9285APJ6

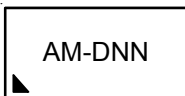

AM- : Product Code
DNN : Date Code

RT9285BPJ6

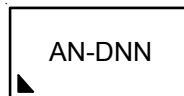

AN- : Product Code
DNN : Date Code

RT9285AGJ6

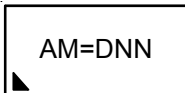

AM= : Product Code
DNN : Date Code

RT9285BGJ6

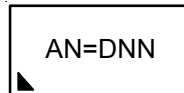

AN= : Product Code
DNN : Date Code

Functional Pin Description

Pin No.		Pin Name	Pin Function
WDFN-8L	TSOT-23-6		
1	--	AGND	Analog Ground.
2	1	LX	LX Pin. Connect this Pin to an inductor. Minimize the track area to reduce EMI.
--	2	GND	Ground.
3, 9 (Exposed Pad)	--	NC	No Internal Connection.
4	--	PGND	Power Ground.
5	6	VDD	Supply Input Voltage. Bypass 1 μ F capacitor to GND to reduce the input ripple.
6	5	VOUT	Output Voltage. The pin internally connects to OVP diode to limit output voltage while LEDs are disconnected.
7	4	EN	Chip Enable (Active High). Note that this pin has an internal pull-down resistance around 300k Ω .
8	3	FB	Feedback. Series connecting a resistor between WLED and ground as a current sense. Sense the current feedback voltage to set the current rating.
	--	GND	Exposed pad should be soldered to PCB board and connected to GND.

Function Block Diagram

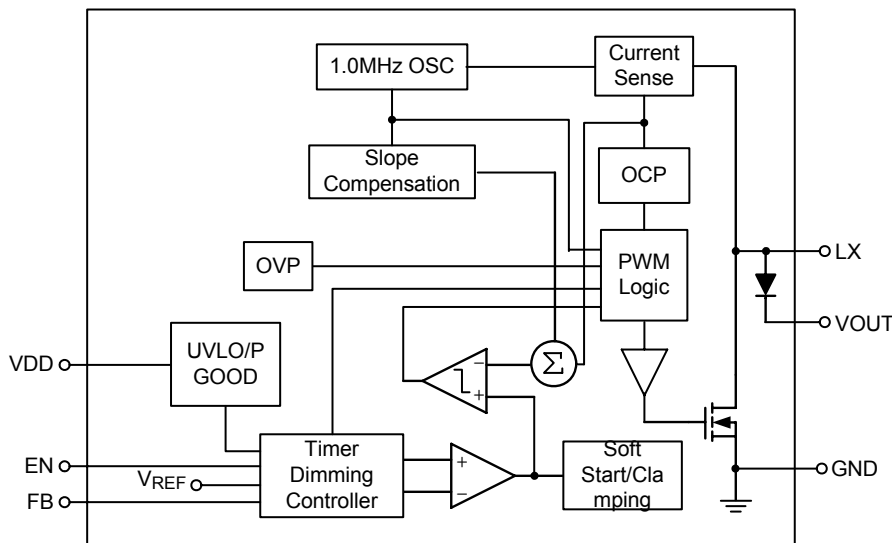

Operation

Soft-Start

The Soft-Start function is made by clamping the output voltage of error amplifier with another voltage source that is increased slowly from zero to near V_{IN} in the Soft-Start period. Therefore, the duty cycle of the PWM will be increased from zero to maximum in this period. The soft-start time is decided by a timer of 1.5ms. The charging time of the inductor will be limited as the smaller duty so that the inrush current can be reduced to an acceptable value.

Over Voltage Protection

The Over Voltage Protection is detected by a junction breakdown detecting circuit. Once V_{OUT} goes over the detecting voltage, LX pin stops switching and the power NMOS is turned off. Then, the V_{OUT} is clamped to be near V_{OVP} .

LED Current Setting

The RT9285 regulates the LED current by setting the current sense resistor (R_{SET}) connecting to feedback and ground. The internal feedback reference voltage is 0.25V. The LED current can be set from following equation easily.

$$I_{LED} \text{ (mA)} = 0.25/R_{SET}$$

In order to have an accurate LED current, precision resistors are preferred (1% is recommended). The table for R_{SET} selection is shown below.

Table 1. R_{SET} Value Selection

I_{LED} (mA)	R_{SET} (Ω)
5	49.9
10	24.9
12	21
15	16.5
20	12.4

Digital Pulse Dimming (RT9285A)

The digital pulse dimming is implemented by checking the low-level duration time of EN pin. As the duration time is in the range of T_{UP} , the LED current will increase 1/16. If the duration time is in the range of T_{DOWN} , the LED current will decrease 1/16. The high-level duration time of EN pin needs larger than T_{DELAY} to make sure the logic can be detected correctly. As the LED current is set to MAX (16/16), it will keep MAX until the decreasing signal is detected. On the other hand, as the LED current is set to MIN (1/16), it will keep MIN until the increasing signal is detected. When the chip turns on, the initial state of LED current is MAX.

Table 2

Feedback Voltage	Time	Symbol
Increase	0.5 μ s to 75 μ s	T_{UP}
Decrease	180 μ s to 300 μ s	T_{DOWN}
Delay between steps	> 0.5 μ s	T_{DELAY}
Shutdown	> 1ms	T_{SHDN}

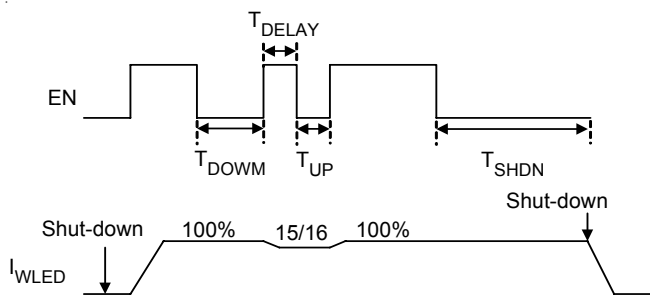

Figure 1

PWM Dimming (RT9285B)

For controlling the LED brightness, the RT9285B can perform the dimming control by applying a PWM signal to EN pin. A low pass filter is implemented inside chip to reduce the slew rate of I_{LED} to prevent the audio noise. The average LED current is proportional to the PWM signal duty cycle. The magnitude of the PWM signal should be higher than the logic high voltage of enable pin, in order to let the dimming control perform correctly.

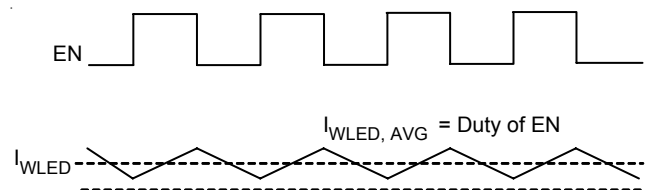

Figure 2

Current Limiting

The current flow through the inductor as charging period is detected by a current sensing circuit. As the value over the current limiting, the N-MOSFET will be turned-off so that the inductor will be forced to leave charging stage and enter discharging stage. Therefore, the inductor current will not increase over the current limiting.

Absolute Maximum Ratings (Note 1)

- Supply Voltage, V_{IN} ----- -0.3 to 6V
- LX Input Voltage ----- -0.3V to 22V
- Output Voltage ----- -0.3V to 21V
- The other pins ----- -0.3V to 6V
- Power Dissipation, P_D @ $T_A = 25^\circ C$
- TSOT23-6 ----- 0.455W
- WDFN-8L 2x2 ----- 0.606W
- Package Thermal Resistance (Note 2)
- TSOT23-6, θ_{JA} ----- 220°C/W
- WDFN-8L 2x2, θ_{JA} ----- 165°C/W
- Junction Temperature ----- 150°C
- Lead Temperature (Soldering, 10 sec.) ----- 260°C
- Storage Temperature Range ----- -65°C to 150°C

Recommended Operating Conditions (Note 3)

- Operation Junction Temperature Range ----- -40°C to 125°C
- Operation Ambient Temperature Range ----- -40°C to 85°C

Electrical Characteristics

($V_{IN} = 3.7V$, FREQ left floating, $T_A = 25^\circ C$, unless otherwise specification)

Parameter	Symbol	Test Conditions	Min	Typ	Max	Unit
System Supply Input						
Operation voltage Range	V_{IN}		2.7	--	5.5	V
Under Voltage Lock Out	V_{UVLO}		1.7	2	2.3	V
Quiescent Current	I_Q	FB = 1.5V, No switch	--	300	450	μA
Supply Current	I_{IN}	FB = 0V, Switch	--	--	2	mA
Shut Down Current	I_{SHDN}	$V_{EN} < 0.4V$	--	2	5	μA
Output						
Line Regulation		$V_{IN} = 3V$ to 4.3V	--	--	3	%
Oscillator						
Operation Frequency	f_{OSC}		--	1	--	MHz
Maximum Duty Cycle			85	90	--	%
Reference Voltage						
Feedback Reference Voltage	V_{REF}		0.237	0.25	0.263	V
Diode						
Forward Voltage	V_{FW}	$I_{FW} = 100mA$	--	0.9	--	V
MOSFET						
On Resistance of MOSFET	$R_{DS(ON)}$		0.5	0.75	1	Ω
Protection						
OVP Threshold	V_{OVP}		--	20	--	V
OCP			--	400	--	mA

Parameter	Symbol	Test Conditions	Min	Typ	Max	Unit
Control Interface						
EN Threshold Voltage	Logic-Low	V_{IL}	--	--	0.4	V
	Logic-High	V_{IH}	1.4	--	--	V
Digital Dimming (for RT9285A)						
Up Brightness Time	T_{UP}	Refer to Figure 1	0.5	--	75	μs
Down Brightness Time	T_{DOWN}	Refer to Figure 1	180	--	300	μs
Delay Between Steps Time	T_{DELAY}	Refer to Figure 1	0.5	--	--	μs
Shut Down Delay Time	T_{SHDN}	Refer to Figure 1	1	--	--	ms

Note 1. Stresses beyond those listed “Absolute Maximum Ratings” may cause permanent damage to the device. These are stress ratings only, and functional operation of the device at these or any other conditions beyond those indicated in the operational sections of the specifications is not implied. Exposure to absolute maximum rating conditions may affect device reliability.

Note 2. θ_{JA} is measured at $T_A = 25^\circ C$ on a low effective thermal conductivity single-layer test board per JEDEC 51-3.

Note 3. The device is not guaranteed to function outside its operating conditions.

Typical Application Circuit

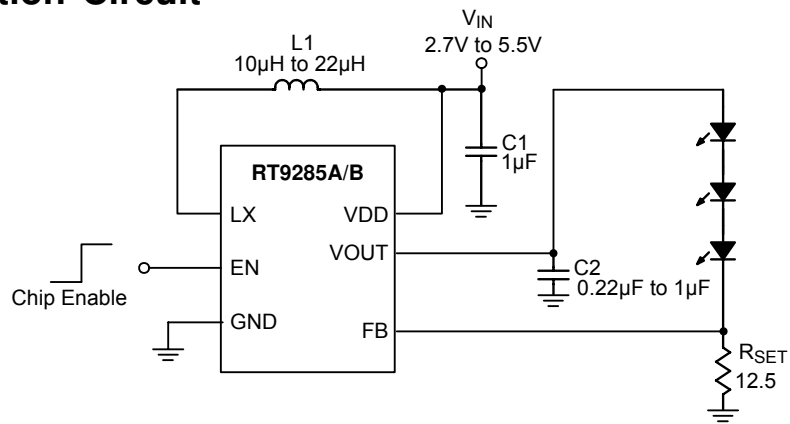

Typical Operating Characteristics

OVP vs. Input Voltage

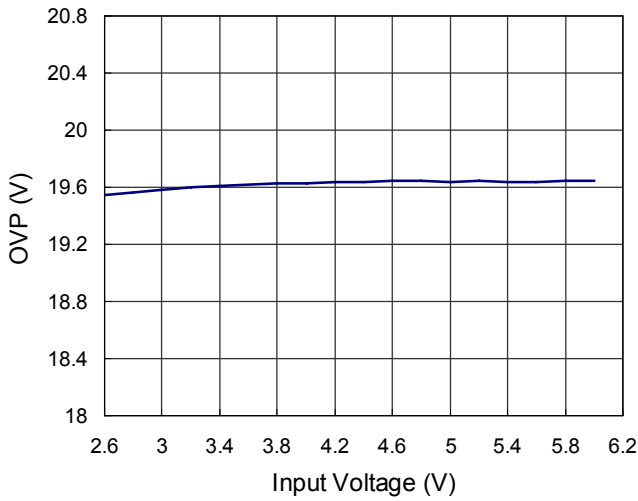

Efficiency vs. Input Voltage

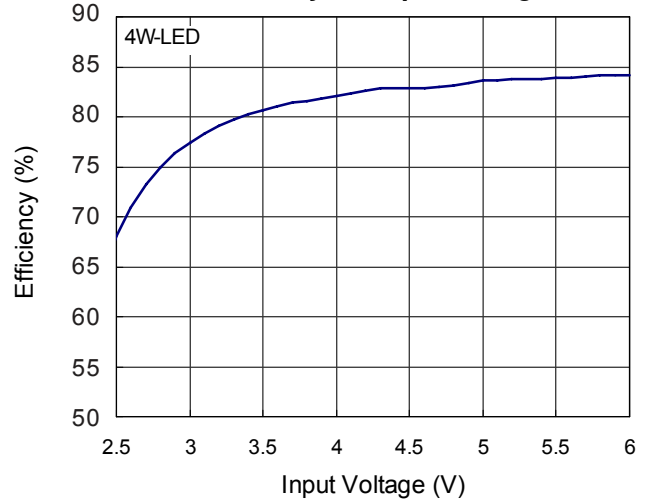

Quiescent Current vs. Input Voltage

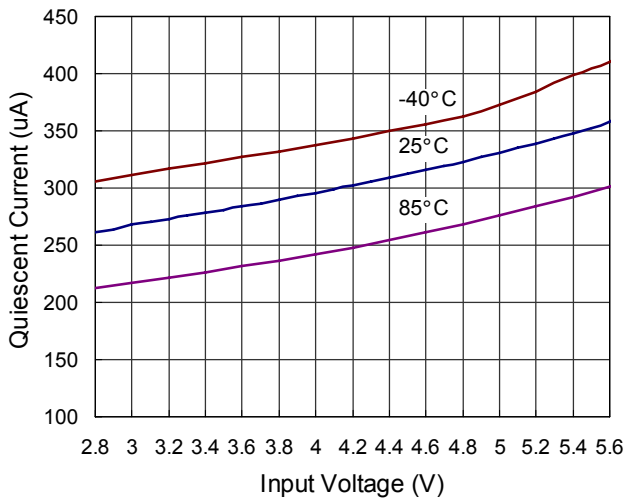

Frequency vs. Input Voltage

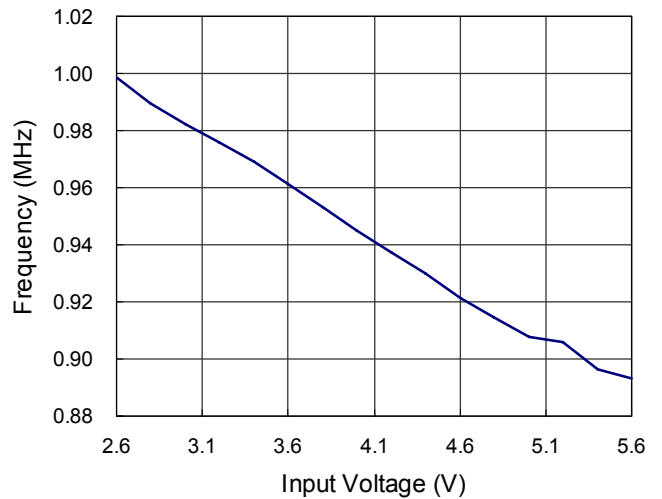

Enable Voltage vs. Input Voltage

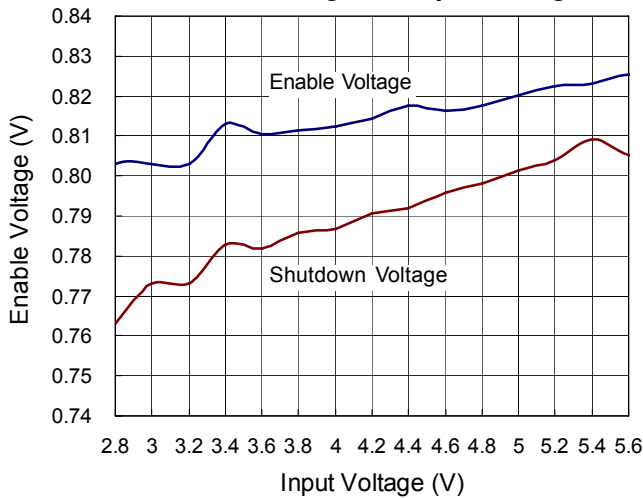

Output Voltage vs. Output Current

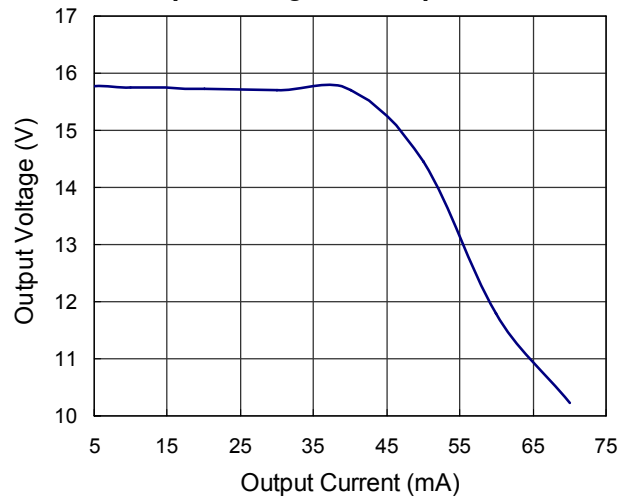

Feedback Reference Voltage vs. Input Voltage

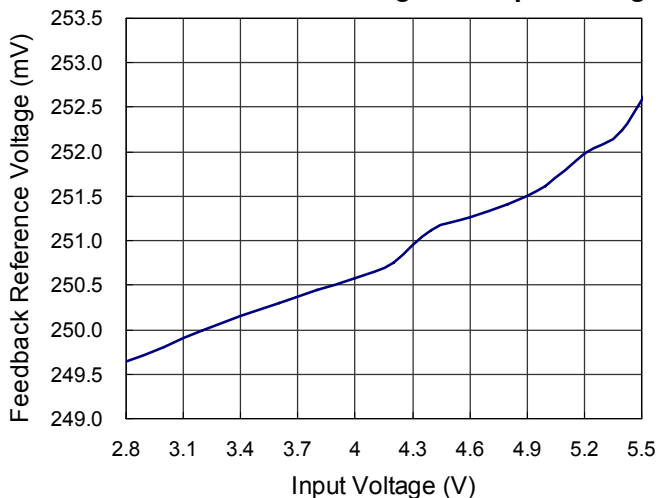

Dimming Operation @ Decrease

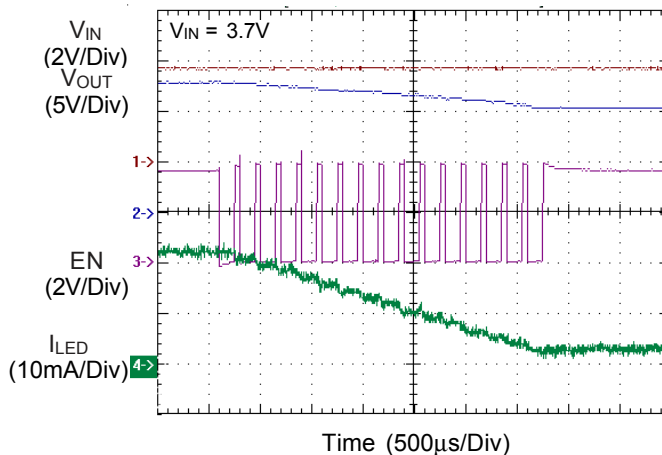

Dimming Operation @ Increase

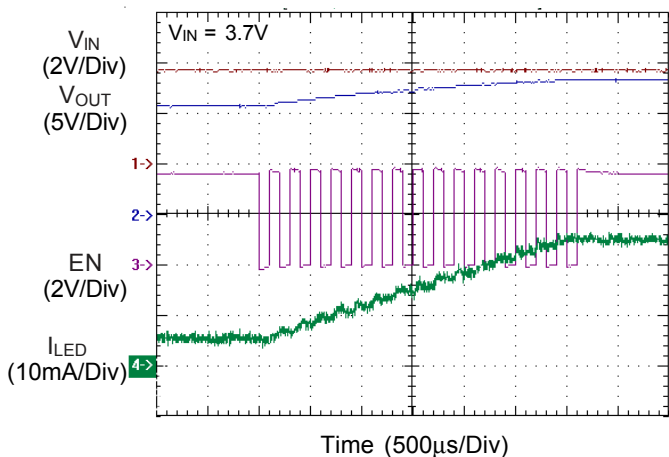

Inrush Current Response

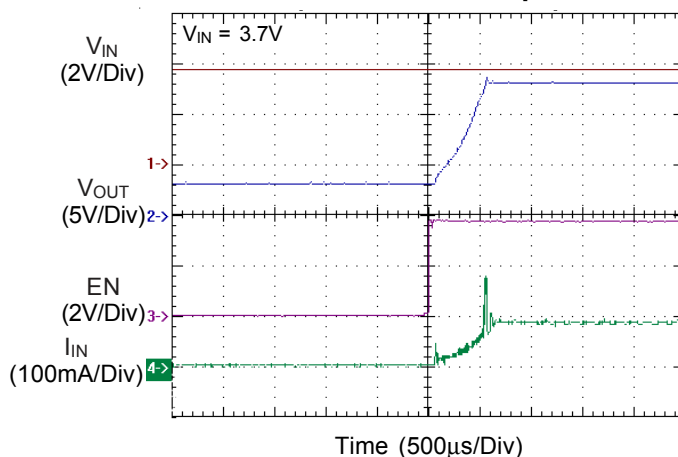

Application Information

LED Current Control

The RT9285A/B regulates the LED current by setting the current sense resistor (R_{SET}) connecting to feedback and ground. The RT9284A/B feedback voltage (V_{FB}) is 0.25V. The LED current (I_{LED}) can be set by a resistor R_{SET} .

$$I_{LED} = 0.25/R_{SET}$$

In order to have an accurate LED current, a precision resistor is preferred (1% is recommended).

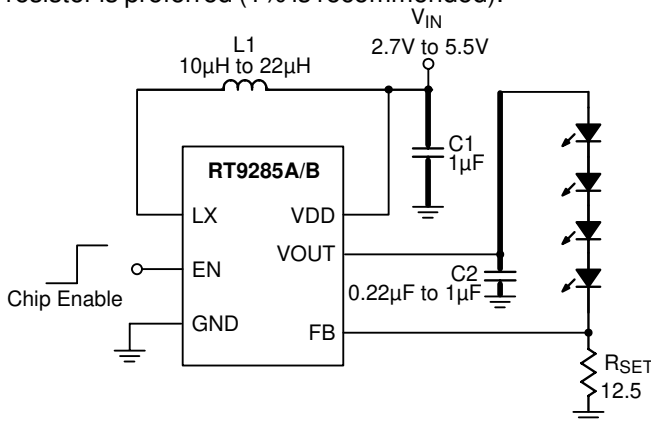

Figure 3. Application for Driving 4 Series WLEDs

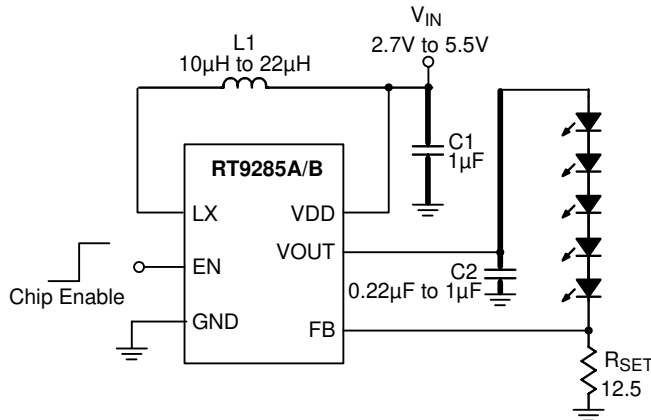

Figure 4. Application for Driving 5 Series WLEDs

Inductor Selection

The recommended value of inductor for 4 to 5WLEDs applications are 10µH to 22µH. For 3WLEDs, the recommended value of inductor is 4.7µH to 22µH. Small size and better efficiency are the major concerns for portable device, such as RT9285A/B used for mobile phone. The inductor should have low core loss at 1MHz and low DCR for better efficiency.

The inductor saturation current rating should be considered to cover the inductor peak current.

Capacitor Selection

Input and output ceramic capacitors of 1µF are recommended for RT9285A/B applications. For better voltage filtering, ceramic capacitors with low ESR are recommended. X5R and X7R types are suitable because of their wider voltage and temperature ranges.

Output Voltage Control

The output voltage of R9285 can be adjusted by the divider circuit on FB pin. Figure 6 shows a 2-level voltage control circuit for OLED application. The output voltage can be calculated by the following equations in Figure 6.

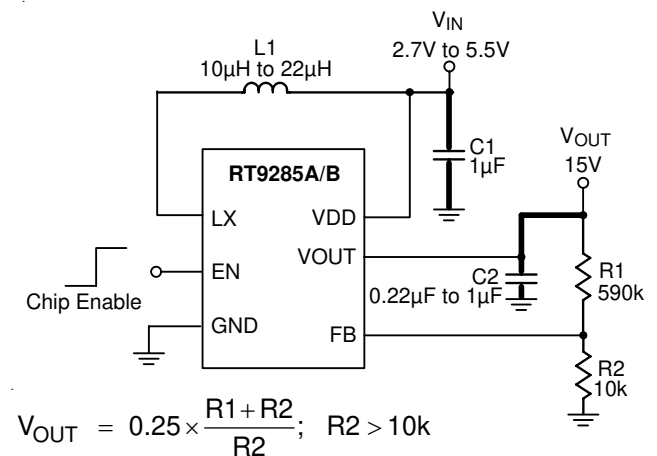

Figure 5. Application for Constant Output Voltage

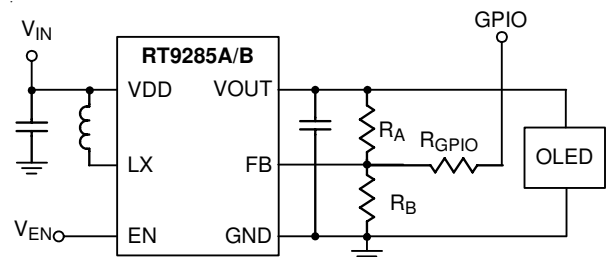

Figure 6. Application Circuit for Output Voltage Control and Related Equations

$$V_{OUT} = R_A \times \left\{ \left(\frac{FB}{R_B} \right) + \left(\frac{FB-GPIO}{R_{GPIO}} \right) \right\} + FB \quad (1)$$

As GPIO = 0V,

$$V_{OUT} = R_A \times \left\{ \left(\frac{0.25}{R_B} \right) + \left(\frac{0.25}{R_{GPIO}} \right) \right\} + 0.25 \quad (2)$$

As GPIO = 2.8V,

$$V_{OUT} = R_A \times \left\{ \left(\frac{0.25}{R_B} \right) + \left(\frac{0.25-2.8}{R_{GPIO}} \right) \right\} + 0.25 \quad (3)$$

$$\text{As GPIO} = 1.8V, V_{OUT} = R_A \times \left\{ \left(\frac{0.25}{R_B} \right) + \left(\frac{0.25-1.8}{R_{GPIO}} \right) \right\} + 0.25 \quad (4)$$

For Efficiency Consideration :

Set $R_A = 990k\Omega$,

If 2 levels are 16V (GPIO = 0V) and 14V (GPIO = 1.8V)

Get $R_B = 16k\Omega$, $R_{GPIO} = 890k\Omega$

Table 3. Suggested Resistance for Output Voltage Control

Conditions	R_A (k Ω)	R_B (k Ω)	R_{GPIO} (k Ω)
Case A : Normal Voltage = 16V (GPIO = 0V) Dimming Voltage = 12V (GPIO = 1.8V)	1100	18	495
Case B : Normal Voltage = 16V (GPIO = 0V) Dimming Voltage = 12V (GPIO = 2.8V)	1200	19.5	840

Considering the output voltage deviation from the GPIO voltage tolerance, as GPIO voltage vibrated by $0 \pm 50mV$ and $1.8(2.8) \pm 5\%$, the output voltage could be kept within $\pm 2.5\%$.

Layout guide

- ▶ A full GND plane without gap break.
- ▶ Traces in bold need to be routed first and should be kept as short as possible.
- ▶ VDD to GND noise bypass : Short and wide connection for the 1 μ F MLCC capacitor between Pin 6 and Pin 2.

- ▶ LX node copper area should be minimized for reducing EMI. (*1)
- ▶ The input capacitor C1 should be placed as closed as possible to Pin 6. (*2)
- ▶ The output capacitor C2 should be connected directly from the Pin 5 to ground rather than across the LEDs. (*3)
- ▶ FB node copper area should be minimized and keep far away from noise sources (Pin 1, Pin 5, Pin 6). (*4)
- ▶ The Inductor is far away receiver and microphone.
- ▶ The voice trace is far away RT9285.
- ▶ The embedded antenna is far away and different side RT9285.
- ▶ R1 should be placed as close as RT9285.
- ▶ The through hole of RT9285's GND pin is recommended as large and many as possible.

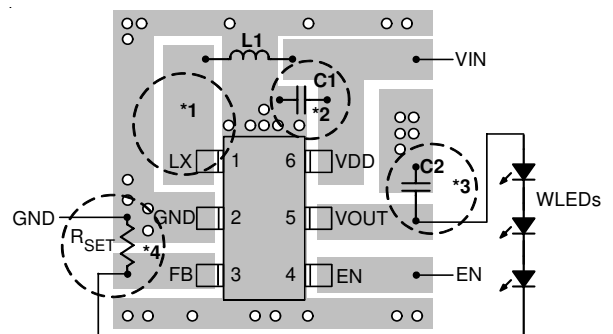

Figure 7. TOP

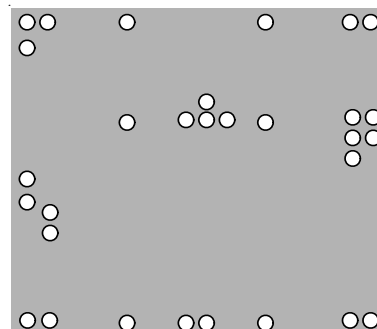
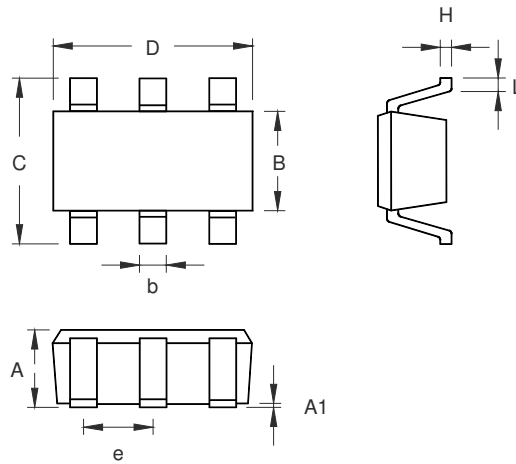

Figure 8. Bottom

Outline Dimension



Symbol	Dimensions In Millimeters		Dimensions In Inches	
	Min	Max	Min	Max
A	0.700	1.000	0.028	0.039
A1	0.000	0.100	0.000	0.004
B	1.397	1.803	0.055	0.071
b	0.300	0.559	0.012	0.022
C	2.591	3.000	0.102	0.118
D	2.692	3.099	0.106	0.122
e	0.838	1.041	0.033	0.041
H	0.080	0.254	0.003	0.010
L	0.300	0.610	0.012	0.024

TSOT-23-6 Surface Mount Package

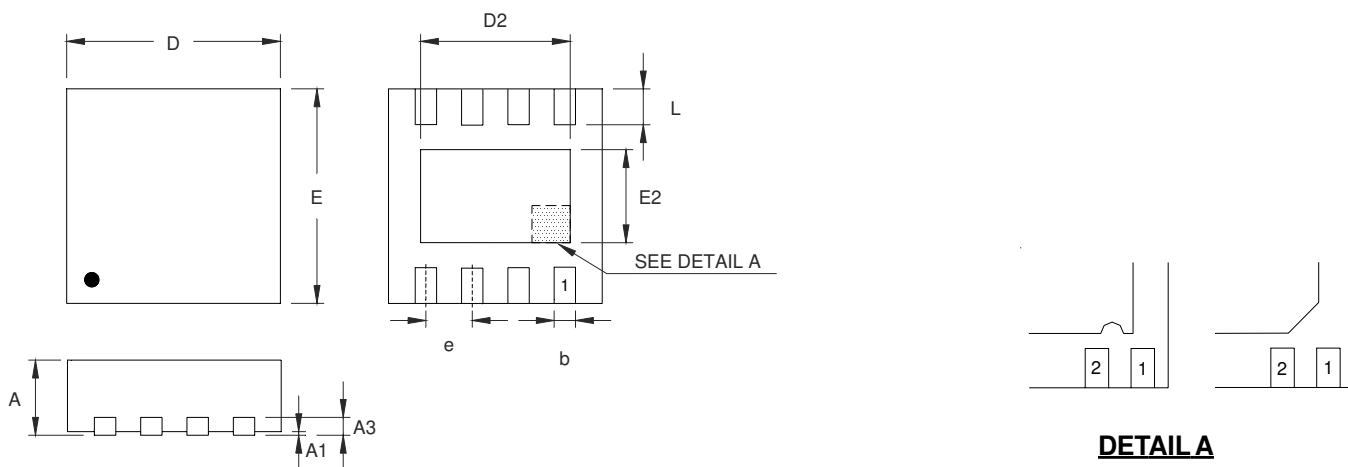

DETAIL A

Pin #1 ID and Tie Bar Mark Options

Note : The configuration of the Pin #1 identifier is optional, but must be located within the zone indicated.

Symbol	Dimensions In Millimeters		Dimensions In Inches	
	Min	Max	Min	Max
A	0.700	0.800	0.028	0.031
A1	0.000	0.050	0.000	0.002
A3	0.175	0.250	0.007	0.010
b	0.200	0.300	0.008	0.012
D	1.950	2.050	0.077	0.081
D2	1.000	1.250	0.039	0.049
E	1.950	2.050	0.077	0.081
E2	0.400	0.650	0.016	0.026
e	0.500		0.020	
L	0.300	0.400	0.012	0.016

W-Type 8L DFN 2x2 Package

Richtek Technology Corporation

5F, No. 20, Taiyuen Street, Chupei City

Hsinchu, Taiwan, R.O.C.

Tel: (8863)5526789

Richtek products are sold by description only. Richtek reserves the right to change the circuitry and/or specifications without notice at any time. Customers should obtain the latest relevant information and data sheets before placing orders and should verify that such information is current and complete. Richtek cannot assume responsibility for use of any circuitry other than circuitry entirely embodied in a Richtek product. Information furnished by Richtek is believed to be accurate and reliable. However, no responsibility is assumed by Richtek or its subsidiaries for its use; nor for any infringements of patents or other rights of third parties which may result from its use. No license is granted by implication or otherwise under any patent or patent rights of Richtek or its subsidiaries.