





REVISIONS				
P	LTR	DESCRIPTION	DATE	APVD
	F2	ECN-22-150900	27APR2022	RK CSD

<b>AMP</b> WIRE RANGE	 <b>E13288</b> Listed
4/0 AWG SOLID OR STRANDED	4/0 AWG STRANDED
 <b>LR7189</b> Certified	
4/0 AWG SOLID OR STRANDED	

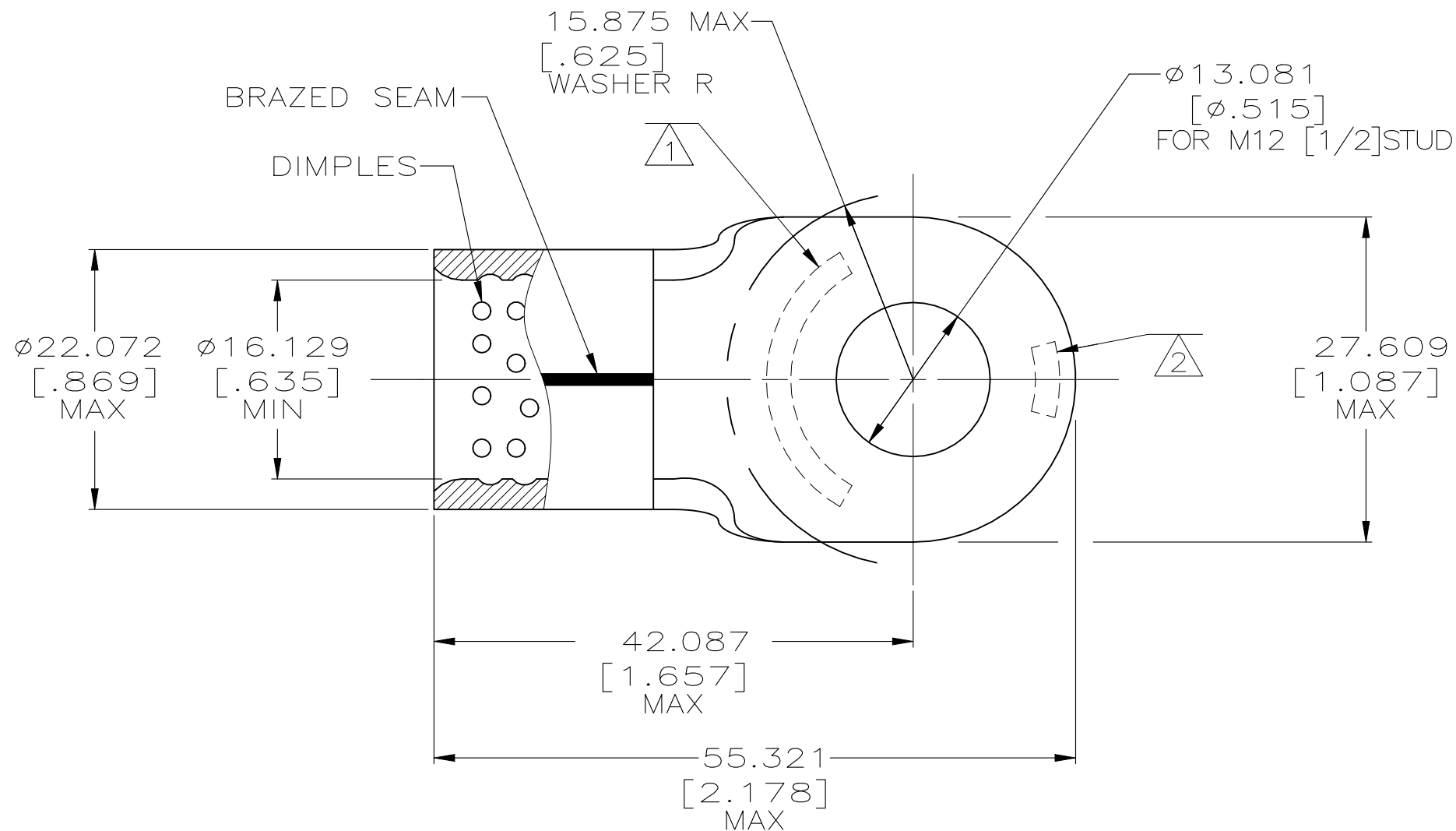

- 1 STAMP AMP 4/0W\* APPROX AS SHOWN
- 2 STAMP AMP 200 APPROX AS SHOWN
- 3 MATERIAL THK: 2.591±0.076[.102±.003]
- 4 TIN PLATE 0.00254[.000100]MIN. EXT.THK PER ASTM B545
- 5 NICKEL PLATE 0.00762[.000300] MIN. EXT. THK. PER SAE AMS QQ-N-290
- 6 NOT UL, CSA OR MILITARY APPROVED. FOR STRANDED WIRE ONLY
- 7 PRODUCT SPECIFICATION UL 486A-B
- 8 COPPER PER ASTM B152, ANNEALED

6/5	343°C [649°F]	50	LOOSE PIECE	321880-1
7/4	170°C [338°F]	50	LOOSE PIECE	321880
	MAX RECOMMENDED TEMPERATURE	QTY	PACKAGE TYPE	PART NO

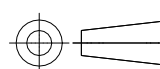
<b>AMP INCORPORATED</b> CUSTOMER SERVICE SYSTEMS		MAX RECOMMENDED OPERATING TEMPERATURE: SEE TABLE	THIS DRAWING IS A CONTROLLED DOCUMENT.		DWN DK SCHRUM 5/25/93	 TE Connectivity					
FOR ADDITIONAL PRODUCT INFORMATION OR COPIES OF DRAWINGS AND TECHNICAL DOCUMENTS	PRODUCT INFORMATION CENTER 1-800-522-6752	VOLTAGE RATING: NOT APPLICABLE	DIMENSIONS: INCHES	TOLERANCES UNLESS OTHERWISE SPECIFIED:	CHK RD HEIM 1/27/94					NAME TERMINAL, RING TONGUE, SOLISTRAND AND STRATO-THERM HR, WIRE SIZE: 4/0 AWG	
FOR APPLICATION TOOLING INFORMATION	TOOLING ASSISTANCE CENTER 1-800-722-1111	WIRE CROSS SECTIONAL AREA RANGE: 96.3-117.0mm <sup>2</sup> [190,000-231,100] CIR MILS SOLID OR STRANDED		0 PLC ± - 1 PLC ± - 2 PLC ± - 3 PLC ± 0.127[.005] 4 PLC ± - ANGLES ± -	APVD RE ROSE 1/27/94	PRODUCT SPEC CR RHOADS 1/27/94	APPLICATION SPEC	SIZE	CAGE CODE	DRAWING NO	RESTRICTED TO
FOR ORDER ENTRY	1-800-526-5142	THIS DRAWING IS A CONTROLLED DOCUMENT FOR AMP INCORPORATED. IT IS SUBJECT TO CHANGE AND THE CONTROLLING ENGINEERING ORGANIZATION SHOULD BE CONTACTED FOR THE LATEST REVISION.	MATERIAL	FINISH	7	7	7	A3	00779	C-321880	-
					CUSTOMER DRAWING		SCALE	SHEET	REV		
							2:1	1 OF 1	F2		