

FMS6418B

Triple Video Driver with Selectable HD/SD Video Filters for RGB, YUV or YPbPr Signals

Features

- Three video anti-aliasing or reconstruction filters
- YUV/RGB/YPbPr signal support
- 2:1 MUX inputs for multiple RGB/YUV/YPbPr inputs
- Selectable 8MHz or 32MHz 6th order filters for SD/HD applications
- DC coupled input, AC coupled output
- All outputs can drive AC coupled 150Ω loads and provide 6dB of gain
- 0.6% differential gain with 0.15° differential phase
- 36dB/octave roll-off on all channels
- Lead (Pb) Free packages - SOIC-16 or TSSOP-14

Applications

- Cable set-top boxes
- Satellite set-top boxes
- DVD players
- HDTV
- Personal Video Recorders (PVR)
- Video On Demand (VOD)

Description

The FMS6418B offers comprehensive filtering for set-top box or DVD applications. This part consists of a triple 6th order filter with selectable 32MHz or 8MHz frequencies.

A 2-to-1 multiplexer is provided on each filter channel. The triple filters can accommodate either YUV, RGB, or YPbPr signals. All channels accept DC coupled ground-referenced 1V signals. The filters provide 2V_{pp} signals into AC coupled terminated loads. The low-pass filters are powered by 3.3V and the outputs by 5.0V.

The FMS6418B is available in both 16-pin SOIC and 14-pin TSSOP packages.

Functional Block Diagram

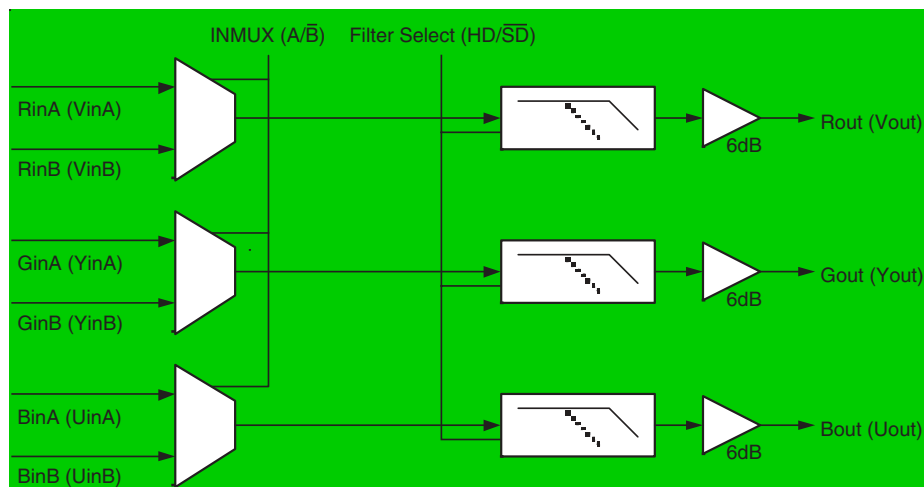

Pin Configurations

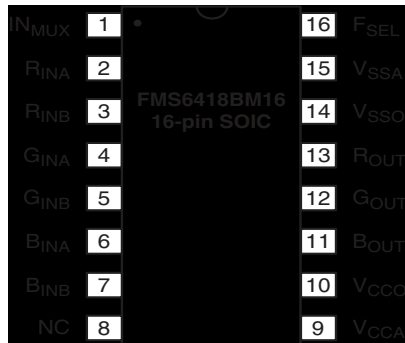
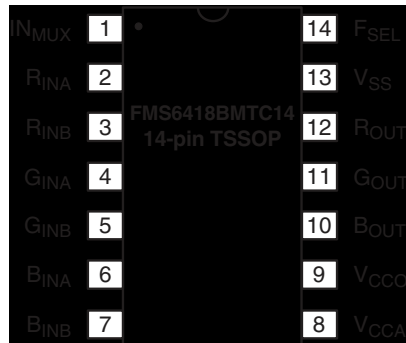

Pin Assignments

TSSOP-14	SOIC-16	Pin Name	Description	Equivalent Circuit
1	1	IN_MUX	Logic input selects between channel <A> or of the RGB inputs. (1): RGB A input, (0): RGB B input	
14	16	F_SEL	Logic Input selects between (0) SD (8MHz) and (1) HD (32MHz) filters	
2	2	R_INA	Analog RED video input - Channel A	
3	3	R_INB	Analog RED video input - Channel B	
4	4	G_INA	Analog GREEN video input - Channel A	
5	5	G_INB	Analog GREEN video input - Channel B	
6	6	B_INA	Analog BLUE video input - Channel A	
7	7	B_INB	Analog BLUE video input - Channel B	
N/A	8	NC	No Connect (float pin)	
8	9	V_CCA	+3.3V power supply for filters	
9	10	V_CCO	+5V power supply for output buffers	
10	11	B_OUT	Filtered Analog BLUE video output from either B_INA or B_INB	
11	12	G_OUT	Filtered Analog GREEN video output from either G_INA or G_INB	
12	13	R_OUT	Filtered Analog RED video output from either R_INA or R_INB	
N/A	14	V_SSO	Ground for output buffers	
N/A	15	V_SSA	Ground for filters	
13	N/A	V_SS	Ground	

11 = TSSOP-14 Pin Numbers
1 = SOIC-16 Pin Numbers

Reliability Information

Parameter	Min.	Typ.	Max.	Unit
Junction Temperature			+150	°C
Storage Temperature Range	-65		+150	°C
Lead Temperature (Soldering, 10s)			+300	°C
Thermal Resistance (θ_{JA}), JEDEC Standard Multi-layer Test Boards, Still Air		70		°C/W

Absolute Maximum Ratings

Parameter	Min.	Max.	Unit
DC Supply Voltage	-0.3	6	V
Analog and Digital I/O	-0.3	$V_{CCO} + 0.3$	V
Output Current Any One Channel (Do Not Exceed)		35	mA

Recommended Operating Conditions

Parameter	Min.	Typ.	Max.	Unit
Operating Temperature Range	0		70	°C
V_{CCO} Range	4.75	5.0	5.25	V
V_{CCA} Range	3.135	3.3	3.465	V

Electrical Characteristics

($T_C = 25^\circ\text{C}$, $V_i = 1V_{pp}$; $V_{CCA} = 3.3V$, $V_{CCO} = 5.0V$, all inputs DC coupled, all outputs AC coupled with $220\mu\text{F}$ into 150Ω , referenced to 400kHz ; unless otherwise noted)

Symbol	Parameter	Conditions	Min.	Typ.	Max	Units
I_{CCA}	Supply Current ¹	V_{CCA} no load	35	45	70	mA
I_{CCO}	Supply Current ¹	V_{CCO} no load	30	45	60	mA
V_i	Input Voltage Max	Reference to ground		1.3		V
V_{il}	Digital Input Low ¹	F_{SEL} , IN_{MUX}	0		0.8	V
V_{ih}	Digital Input High ¹	F_{SEL} , IN_{MUX}	2.4		V_{CCO}	V
PSSR	PSSR (all channels)	DC		-40		dB

Standard Definition Electrical Specifications

($T_C = 25^\circ\text{C}$, $V_i = 1V_{pp}$; $V_{CCA} = 3.3V$, $V_{CCO} = 5.0V$, $F_{SEL} = 0$, all inputs DC coupled, all outputs AC coupled with $220\mu\text{F}$ into 150Ω , referenced to 400kHz ; unless otherwise noted)

Symbol	Parameter	Conditions	Min.	Typ.	Max	Units
AV_{RGBSD}	RGB SD Gain ¹	R,G,B channels SD Mode	5.6	6.0	6.4	dB
f_{1dBSD}	-1dB Bandwidth for SD ¹	R,G,B channels	5.0	7.1		MHz
f_{CSD}	-3dB Bandwidth for SD ¹	R,G,B channels	6.0	8.2		MHz
f_{SBS}	Attenuation: SD (stopband reject) ¹	R,G,B channels at $f = 27\text{MHz}$	-50	-60		dB
dG	Differential Gain	R,G,B channels		0.6		%
$d\phi$	Differential Phase	R,G,B channels		0.15		°
THD	Output Distortion (all channels)	$V_{OUT} = 1.8V_{pp}$, RGB Out at 1MHz		0.4		%
X_{TALK}	Crosstalk (channel-to-channel)	at 1MHz		-70		dB
IN_{MUXISO}	IN_{MUX} Isolation	at 1MHz		-90		dB
SNR	Signal-to-Noise Ratio	R,G,B channels, NTC-7 weighting 4.2MHz lowpass, 100kHz highpass		73		dB
t_{pdSD}	Prop Delay for SD	Delay from input to output at 4.5MHz		70		ns

High Definition Electrical Specifications

($T_C = 25^\circ\text{C}$, $V_i = 1V_{pp}$; $V_{CCA} = 3.3V$, $V_{CCO} = 5.0V$, $F_{SEL} = 1$, all inputs DC coupled, all outputs AC coupled with $220\mu\text{F}$ into 150Ω , referenced to 400kHz ; unless otherwise noted)

Symbol	Parameter	Conditions	Min.	Typ.	Max	Units
AV_{RGBHD}	RGB HD Gain ¹	R,G,B channels HD Mode	5.6	6.0	6.4	dB
f_{1dBHD}	-1dB Bandwidth for HD ¹	R,G,B channels	25	27		MHz
f_{CHD}	-3dB Bandwidth for HD ¹	R,G,B channels	30	32		MHz
f_{SBHD}	Attenuation: HD (stopband reject) ¹	R,G,B channels at $f = 74.25\text{MHz}$	-35	-40		dB
X_{TALKB}	Crosstalk (channel-to-channel)	at 1MHz		-70		dB
IN_{MUXISO}	IN_{MUX} Isolation	at 1MHz		-90		dB
SNR	Signal-to-Noise Ratio	R,G,B channels, Unified Weighting		73		dB
t_{pdHD}	Prop Delay for HD	Delay from input to output at 20MHz		20		ns

Notes:

- 100% tested at 25°C

Standard Definition Typical Performance Characteristics

($T_C = 25^\circ\text{C}$, $V_i = 1V_{pp}$; $V_{CCA} = 3.3V$, $V_{CCO} = 5.0V$, $F_{SEL} = 0$, all inputs DC coupled, all outputs AC coupled with $220\mu\text{F}$ into 150Ω , referenced to 400kHz ; unless otherwise noted)

Figure 1. SD Frequency Response

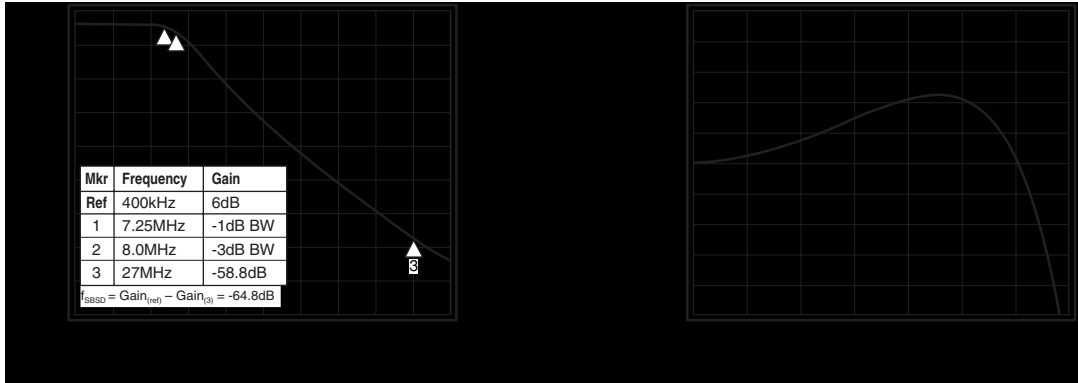

Figure 2. SD Gain Flatness

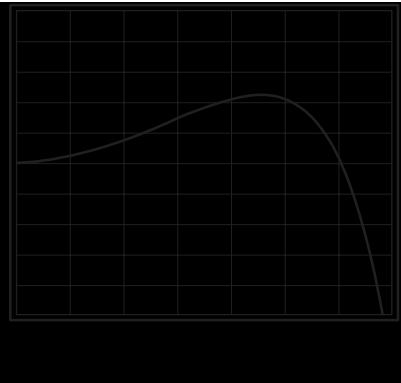

Figure 3. Noise vs. Frequency

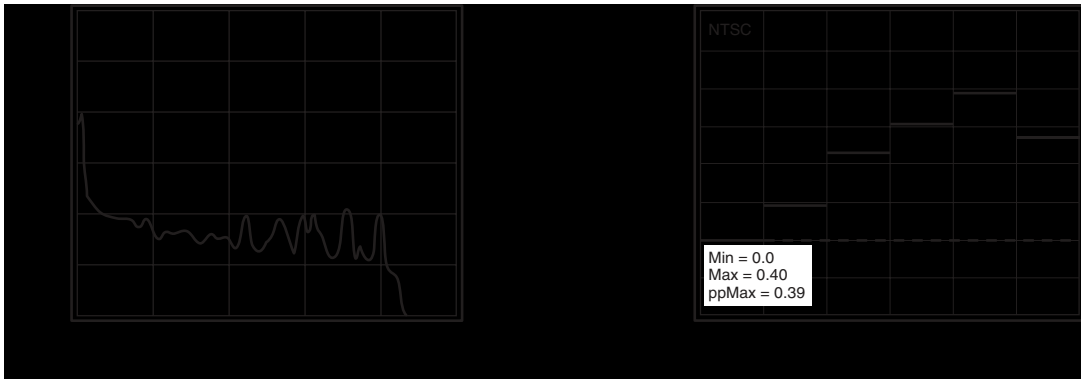

Figure 4. Differential Gain

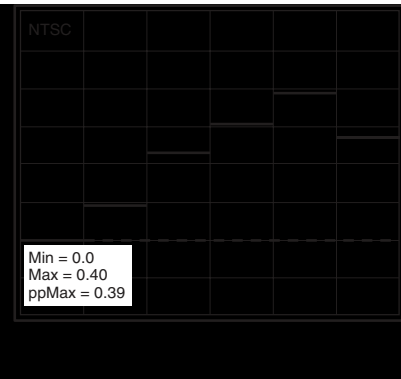

Figure 5. Group Delay vs. Frequency

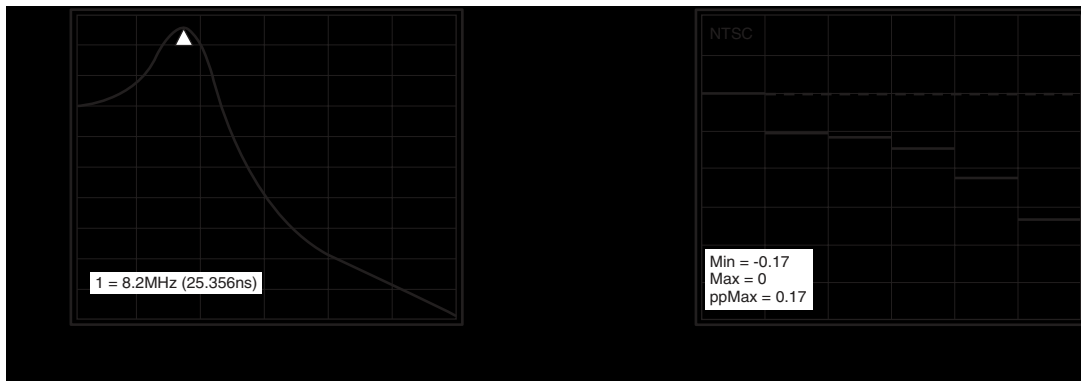
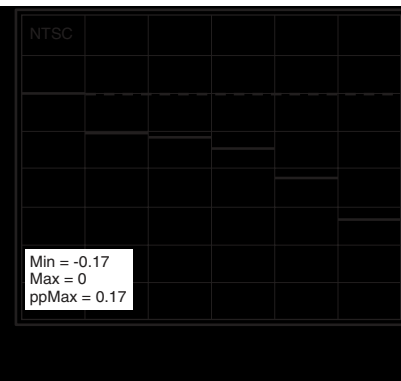

Figure 6. Differential Phase



High Definition Typical Performance Characteristics

($T_C = 25^\circ\text{C}$, $V_i = 1V_{pp}$; $V_{CCA} = 3.3V$, $V_{CCO} = 5.0V$, $F_{SEL} = 1$, all inputs DC coupled, all outputs AC coupled with $220\mu\text{F}$ into 150Ω , referenced to 400kHz ; unless otherwise noted)

Figure 7. HD Frequency Response

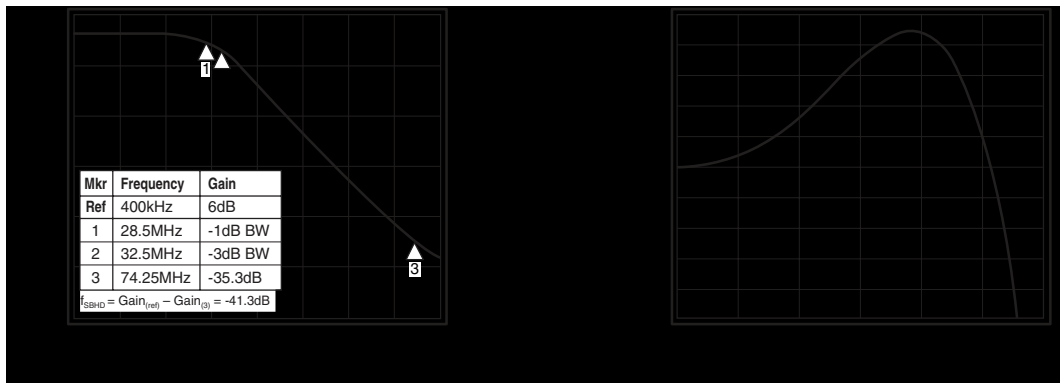

Figure 8. HD Gain Flatness

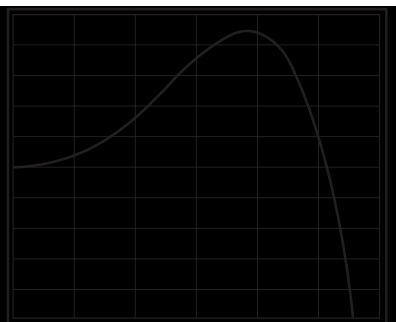
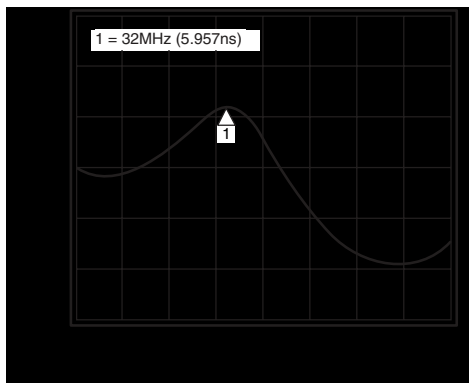

Figure 9. Group Delay vs. Frequency



General Description

The FMS6418B offers comprehensive filtering for set top box or DVD applications. This part consists of a triple 6th order filter with selectable 32MHz or 8MHz frequencies. A 2-to-1 multiplexer is provided on each filter. The filters are intended for either YUV, RGB, or YPbPr signals. All channels accept DC coupled ground-referenced 1V signals. The filters provide $2V_{pp}$ signals into AC coupled terminated loads. All channels provide 6dB gain, accept 1V ground referenced inputs, and drive AC coupled loads. The low-pass filters are powered by 3.3V and the output buffers are powered by 5.0V.

The FMS6418B is a next generation filter solution from Fairchild Semiconductor addressing the expanding filtering needs for set top boxes, and DVD players. The product provides selectable filtering with cutoff frequencies of 32MHz or 8MHz on the RGB/YUV/YPbPr channels. Thus, the FMS6418B addresses the requirement for a single set top box to be compatible with a variety of resolution standards. Multiplexers on the RGB channels provide further flexibility. For DVD, set-top box, and TV applications, the product provides filtering and output drive amplification for three channels of outputs (RGB/YUV/YPbPr).

Applications

DC Levels

At any given time, the input signal's DC levels must be between 0.0V and 1.3V to utilize the optimal headroom and to avoid clipping on the outputs.

Single Supply +5V Operation

For low power consumption, the FMS6418B was designed to operate off of 5V and 3.3V. V_{CCA} can be operated from 5V instead of 3.3V and still meet specifications, except power consumption. When the 3.3V supply is increased to 5V, the typical current consumption increases by 5mA. The net effect is the part dissipates an additional 22 percent of power.

Driving the Digital Pins with 3.3V or 5V Logic

Either is allowed as long as the V_{IH} and V_{IL} are adhered to.

Typical Application Diagrams

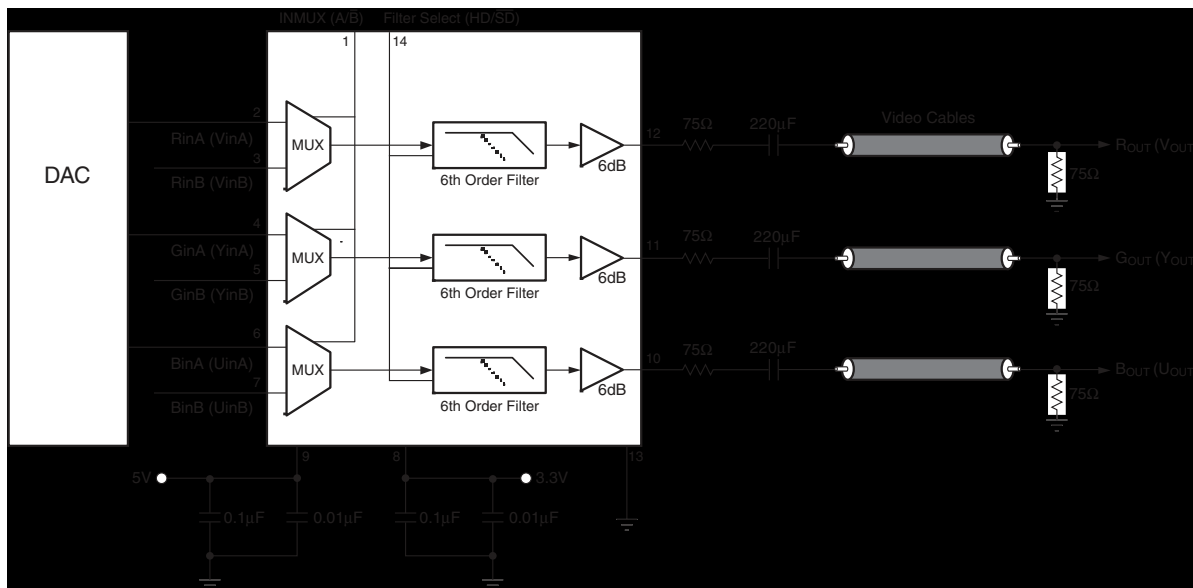

Figure 10. TSSOP typical application diagram

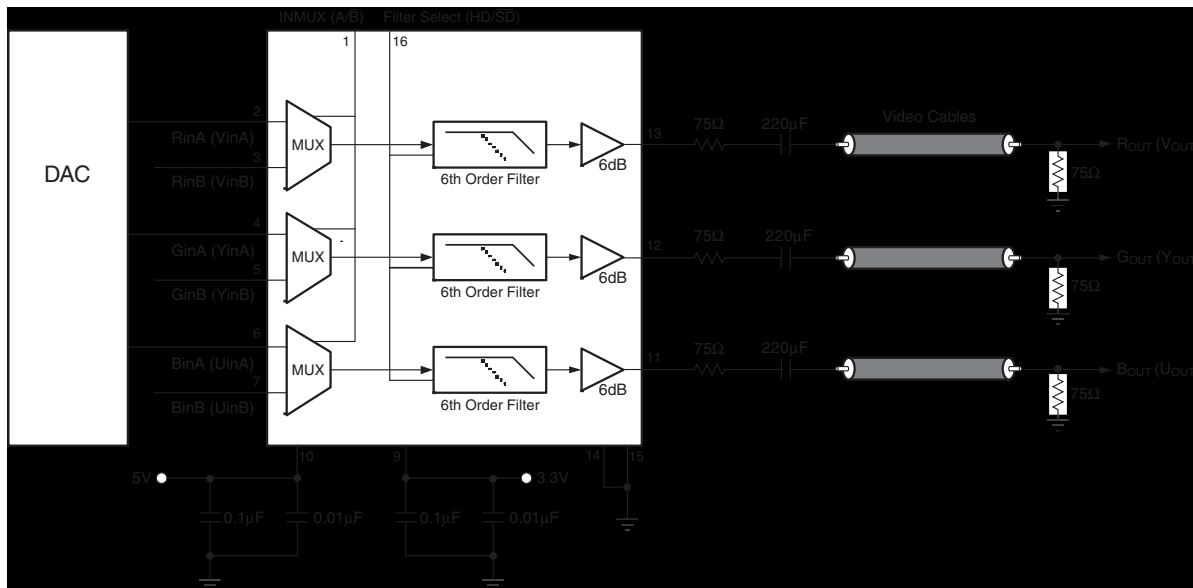
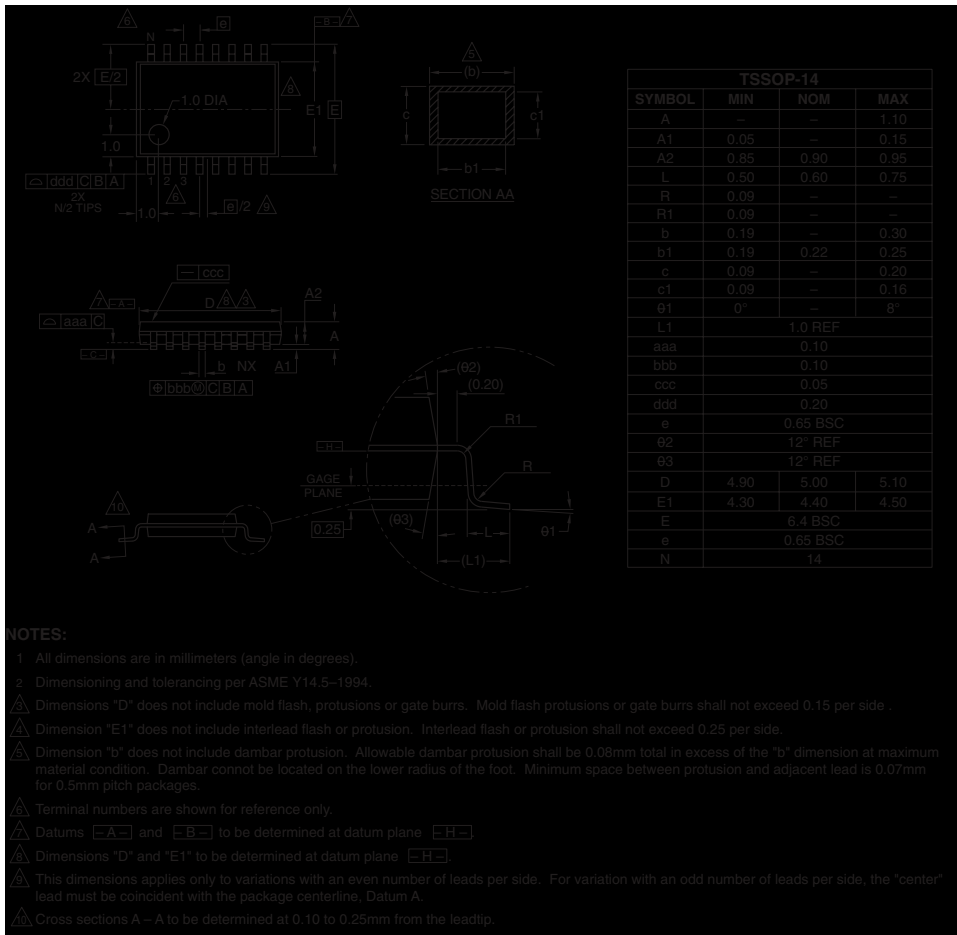

Figure 11. SOIC typical application diagram

Mechanical Dimensions

TSSOP-14



SOIC-16

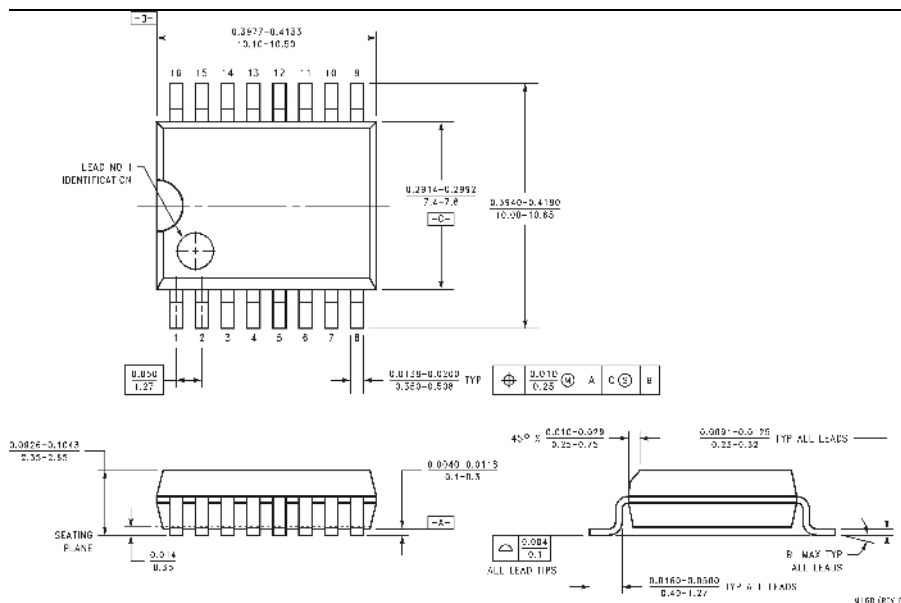

Ordering Information

Model	Part Number	Lead Free	Package	Container	Pack Qty.
FMS6418B	FMS6418BMTc14	Yes	14-pin TSSOP	Tube	94
FMS6418B	FMS6418BMTc14X	Yes	14-pin TSSOP	Tape & Reel	2,500
FMS6418B	FMS6418BM16	Yes	16-pin SOIC	Tube	45
FMS6418B	FMS6418BM16X	Yes	16-pin SOIC	Tape & Reel	1,000

Temperature range for all parts: 0°C to +70°C.

