

LTC4160EPDC / LTC4160EPDC-1

Switching Power Manager with USB On-the-Go and Overvoltage Protection

DESCRIPTION

Demonstration Circuit DC1463A is a Switching Power Manager with USB On-the-Go and Overvoltage Protection featuring the LTC[®]4160.

PERFORMANCE SUMMARY

Specifications are at $T_A = 25^\circ\text{C}$

SYMBOL	PARAMETER	CONDITIONS	MIN	TYP	MAX	UNITS
V _{BUS}	Bus Input Voltage Range		4.35		6	V
V(LDO3V3)	3.3V LDO Output	V _{OUT} > 3.5V	3.1		3.4	V
V(BAT)	Battery Float Voltage	LTC4160 Constant Voltage Mode LTC4160-1 Constant Voltage Mode	4.15 4.05		4.23 4.13	V
I(BAT)	Battery Charge Current	Constant Current Mode, R _{PROG} = 2.00k	485		515	mA
V _{OUT}	Output Voltage	I _{LIM} [1..0] = 01b, I(V _{OUT}) ≤ 1.25A, V(BAT) > 3.6V I(V _{OUT}) ≤ 1.25A, V(BAT) < 3.6V	V(BAT) 3.6V		V _{BAT} + 0.45V	V V
V _{OTG}	V _{BUS} voltage in OTG mode	I(V _{BUS}) ≤ -500mA	4.5	5	5.5	V

QUICK START PROCEDURE

Refer to Figure 1 for the proper measurement equipment setup and jumper settings and follow the procedure below.

NOTE. When measuring the input or output voltage ripple, care must be taken to avoid a long ground lead on the oscilloscope probe. Measure the input or output voltage ripple by touching the probe tip directly across the V_{BUS} or V_{OUT}(x) and GND terminals. See Figure 2 for proper scope probe technique.

1. Set all jumpers as shown in Figure 1 and LD1 = 0A, PS1 = 5V, LD2 = 0A, LD3 = 0A, PS2 = 3.6V. Observe V_{OUT} (VM4), LDO3V3 (VM3), and V(NTC) (VM2). The LTC4160 is operating as USB power manager. The current from PS1 will try to be the charging current * (3.6V/5V), or approximately 400mA, but will be limited by the input current limiter to ~ 100mA.
2. Increase LD3 to 80mA, and LD2 to 25mA. Observe V_{OUT}(VM4), I(V_{USB}) (AM1) and LDO3V3 (VM3). Set LD2 to 0A. The loads on V_{OUT} and LDO3V3 are now reducing the charge current further.
3. Increase LD3 to 250mA. Observe V_{OUT}(VM4), I(V_{USB}) (AM1). The load on V_{OUT} will engage the input current limit, and V_{OUT} will drop until the ideal diode engages to provide the difference current.

4. Change JP1 & JP2 to '1'. Observe VOUT(VM4) and I(VUSB) (AM1). The input current limit is now 500mA, and the load on VOUT is 250mA, so the battery charge current will be approximately 250mA.
5. Increase LD3 to 750mA. Observe VOUT(VM4) and I(VUSB)(AM1). The load on VOUT again exceeds the input current limit and the VOUT voltage will drop until the ideal diode turns on and supplies current from the battery.
6. Change JP1 to '0'. Observe VOUT(VM4) and I(VUSB) (AM1). The input current limit is now 1A, and the battery is charging at 250mA. VOUT is loaded at 750mA, so only the remaining current is available to charge the battery.
7. Increase LD3 to 1.25A. Observe VOUT(VM4) and I(VUSB) (AM1). Set LD3 to 0A. Observe I(BAT) (AM4).The input current limit is activated and VOUT will drop until the ideal diode turns on.
8. Increase PS2 until I(BAT) is less than 25mA. Observe V(BAT) (VM5). Set PS2 to 3.6V.
9. Disconnect PS1. Change JP3 (ENOTG) to 'ON'. Observe VUSB (VM1) and V(CLPROG)(VM6). Although PS1 is disconnected, the USB On-The-Go mode is enabled, and the LTC4160 is providing VUSB from the battery.
10. Increase LD1 to 500mA. Observe VUSB(VM1) and V(CLPROG)(VM6). In On-The-Go mode the LTC4160 can provide 500mA of output current on the USB.
11. Reset the Jumpers to their default position.

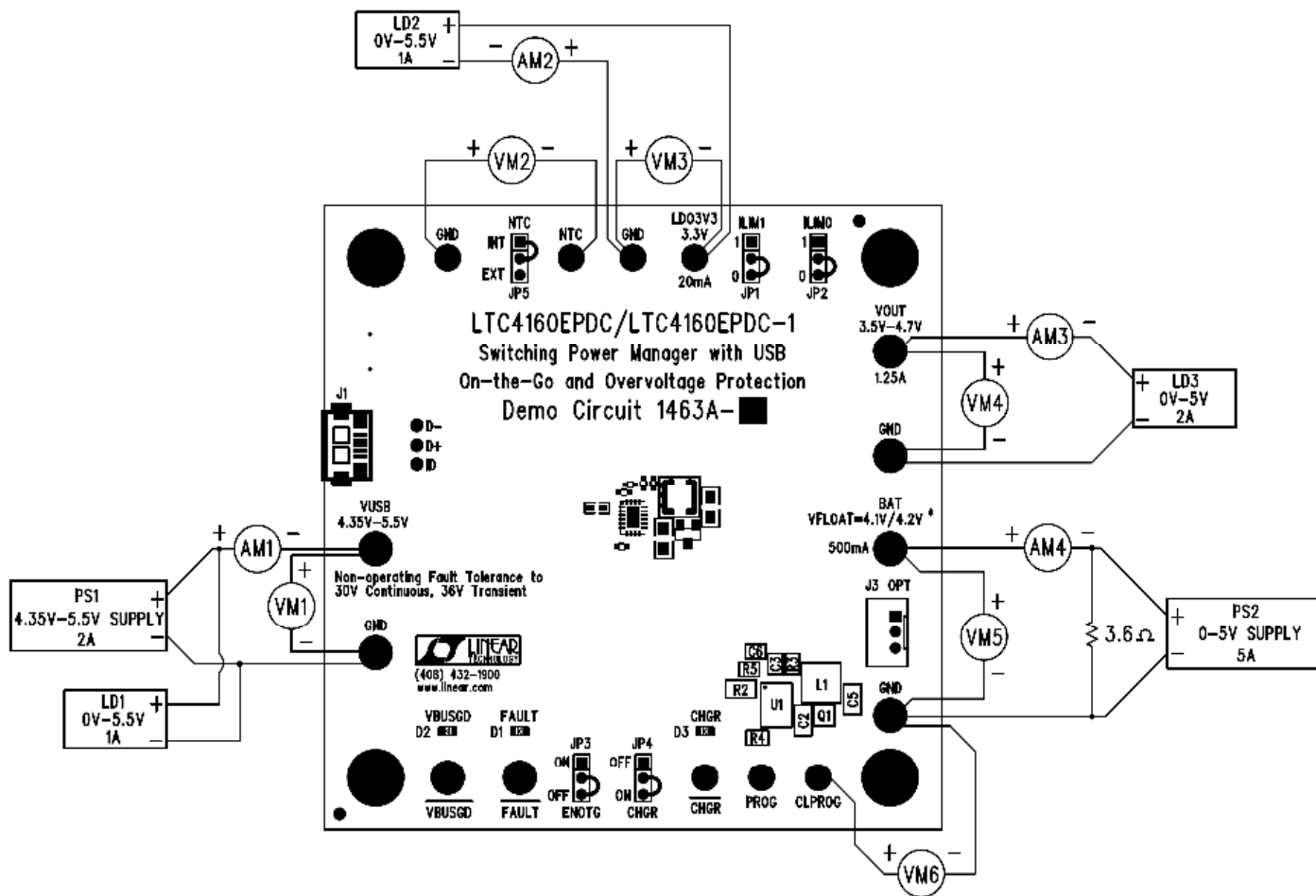

Figure 1. Proper Measurement Equipment Setup for DC1463A

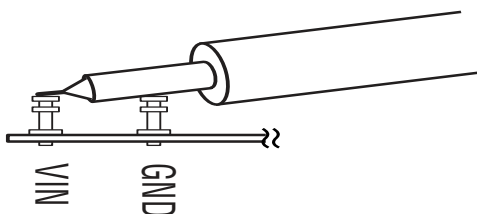

Figure 2. Measuring Input or Output Ripple

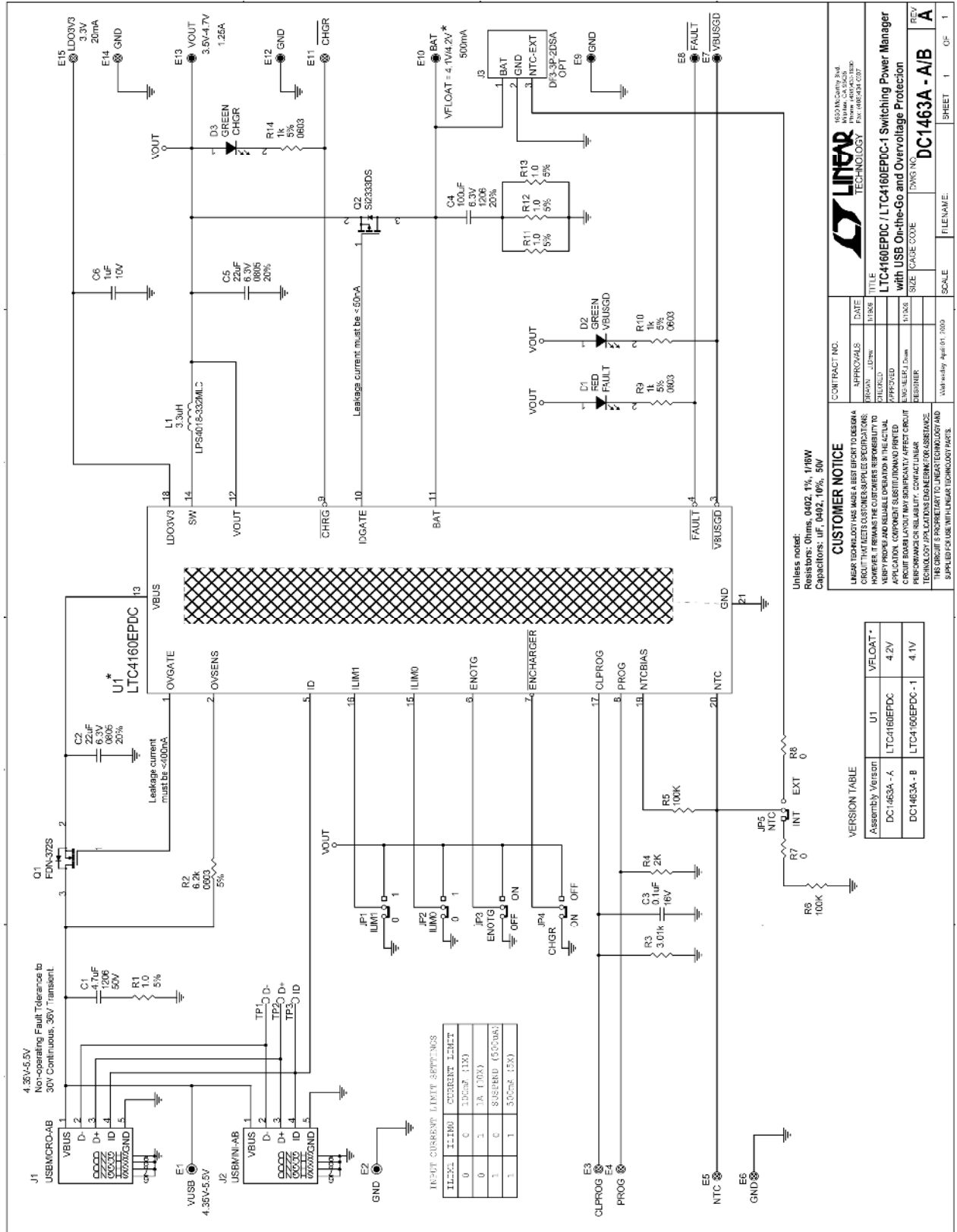

Figure 3. Circuit Schematic

Qty	Reference	Part Description	Manufacture / Part #	
REQUIRED CIRCUIT COMPONENTS:				
1	2	C2,C5	CAP, CHIP, X5R, 22 μ F, \pm 20%, 6.3V, 0805	TAIYO-YUDEN, JMK212BJ226MG
2	1	C3	CAP, CHIP, X7R, 0.1 μ F, \pm 10%, 16V, 0402	MURATA, GRM155R71C104KA88
3	1	C6	CAP, CHIP, X5R, 1.0 μ F, \pm 10%, 10V, 0402	MURATA, GRM155R61A105KE15D
4	1	Q1	MOSFET, 30V, 50m Ω , 2.6A, SuperSOT-3	FAIRCHILD, FDN-372S
5	1	R2	RES, CHIP, 6.2k Ω , 1/10W, 5%, 0603	VISHAY, CRCW06036K20JNED
6	1	R3	RES, CHIP, 3.01k Ω , 1/16W, 1%, 0402	VISHAY, CRCW04023K01FKED
7	1	R4	RES, CHIP, 2.00k Ω , 1/16W, 1%, 0402	VISHAY, CRCW04022K00FKED
8	1	L1	IND, SMT, 3.3uH, \pm 20%, 80m Ω , 2.2A, 4.4mmX4.4mm	COILCRAFT, LPS4018-332MLC
9	1	U1(Option A) U1(Option B)	Switching Power Manager with USB On-the-Go And Overvoltage Protection	LINEAR TECH., LTC4160EPDC LINEAR TECH., LTC4160EPDC-1
ADDITIONAL DEMO BOARD CIRCUIT COMPONENTS:				
1	1	C1	CAP, CHIP, X7R, 4.7 μ F, \pm 10%, 50V, 1206	MURATA, GRM31CR71H475KA12L
2	1	C4	CAP, CHIP, X5R, 100 μ F, \pm 20%, 6.3V, 1206	MURATA, GRM31CR60J107ME39L
3	1	D1	LED, RED, 0603	PANASONIC, LNJ208R8ARA
4	2	D2,D3	LED, GREEN, 0603	PANASONIC, LNJ336W83RA
5	1	Q2	MOSFET, -12V, 35m Ω , -5.3A, SOT-23	VISHAY, Si2333DS
6	4	R1,R11,R12,R13	RES, CHIP, 1.0 Ω , \pm 5%, 1/16W, 0402	VISHAY, CRCW04021R00JNED
7	2	R5,R6	RES, CHIP, 100k Ω , \pm 1%, 1/16W, 0402	VISHAY, CRCW0402100KFKED
8	2	R7,R8	RES, CHIP, 0 Ω jumper, 1/16W, 0402	VISHAY, CRCW04020000Z0ED
9	3	R9,R10,R14	RES, CHIP, 1.0k Ω , 5%, 1/10W, 0603	VISHAY, CRCW06031K00JNED
HARDWARE FOR DEMO BOARD ONLY:				
1	1	J1	CONN, USB MICRO-A/B	HIROSE, ZX62-AB-5PA
2	1	J2	CONN, USB MINI-A/B	MOLEX, 56579-0576
3	0	J3-OPT	CONN, DF3-3P-2DSA	HIROSE, DF3-3P-2DSA
4	5	JP1,JP2,JP3,JP4,JP5	HEADER, 3 PINS 2mm	SAMTEC, TMM-103-02-L-S
5	5	JP1,JP2,JP3,JP4,JP5	SHUNT, 2mm	SAMTEC, 2SN-BK-G
6	8	E1,E2,E7,E8,E9,E10,E12,E13	TURRET, 0.09 DIA	MILL-MAX, 2501-2
7	7	E3,E4,E5,E6,E11,E14,E15	TURRET, 0.061 DIA	MILL-MAX, 2308-2
8	4		STAND-OFF, NYLON 0.375" tall (SNAP ON)	KEYSTONE, 8832 (SNAP ON)

Figure 4. Bill of Materials