



# LINKLED LED LIGHT ENGINES



Patents pending

## FEATURES / BENEFITS

- ▲ Extremely long life of 50,000 hours at 55°C PCB temperature
- ▲ Modular “Plug & Play” system for flexible design in curved or unusually shaped areas.
- ▲ Available in 6 colors (cool white, warm white, red, blue, green, and amber)
- ▲ Aluminium based PCB for easier heat dissipation and more efficient operation
- ▲ Peel & stick mounting tape for easy installation

## OPERATING CONDITIONS

- ▲ Recommended PCB temp=55°C  
Maximum PCB temp = 105°C
- ▲ LED Life @ 65°C PCB temp = 50,000 hours
- ▲ For maximum performance, all “LinkLED” LED Light Engines should be adhered to an appropriate heat sink
- ▲ Thermal conductivity = 1.3W/m-k
- ▲ Breakdown voltage = 2kV

## APPLICATIONS

- ▲ Cove lighting
- ▲ Bars / Reception areas
- ▲ Channel Letters
- ▲ Advertising
- ▲ Any application requiring efficiency, long life and flexibility in size and shape of light source.

## MECHANICAL DIMENSIONS

Length = 42mm (1.65”)  
Width = 14mm (0.55”)  
Height = 7.5mm (0.29”)

## MATERIALS/FINISH

- ▲ LUXEON® I LEDs
- ▲ 1.6mm Aluminium clad PCB substrate
- ▲ White solder resist finish

## PART NUMBERS

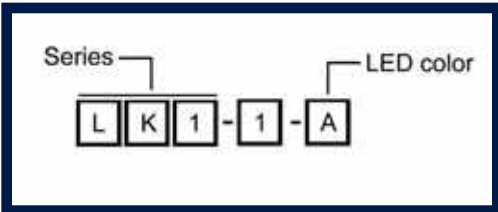

LED Color (A)
W = Cool White
WW = Warm White
R = Red
G = Green
B = Blue
A = Amber

Recommended Cables:
CT2-E300 = 2 way input lead
CT2-100 = 2 way link lead 100mm
CT2-200 = 2 way link lead 200mm
CT2-C = 2 way common connector

Dialight reserves the right to make changes at any time in order to supply the best product possible.

**Dialight Corporation**  
1501 Route 34 South • Farmingdale, NJ 07727 USA  
Tel: (1) 732-919-3119 • Fax: (1) 732-751-5778 • www.dialight.com



MDEXLKLD\_C

## WIRING INFORMATION

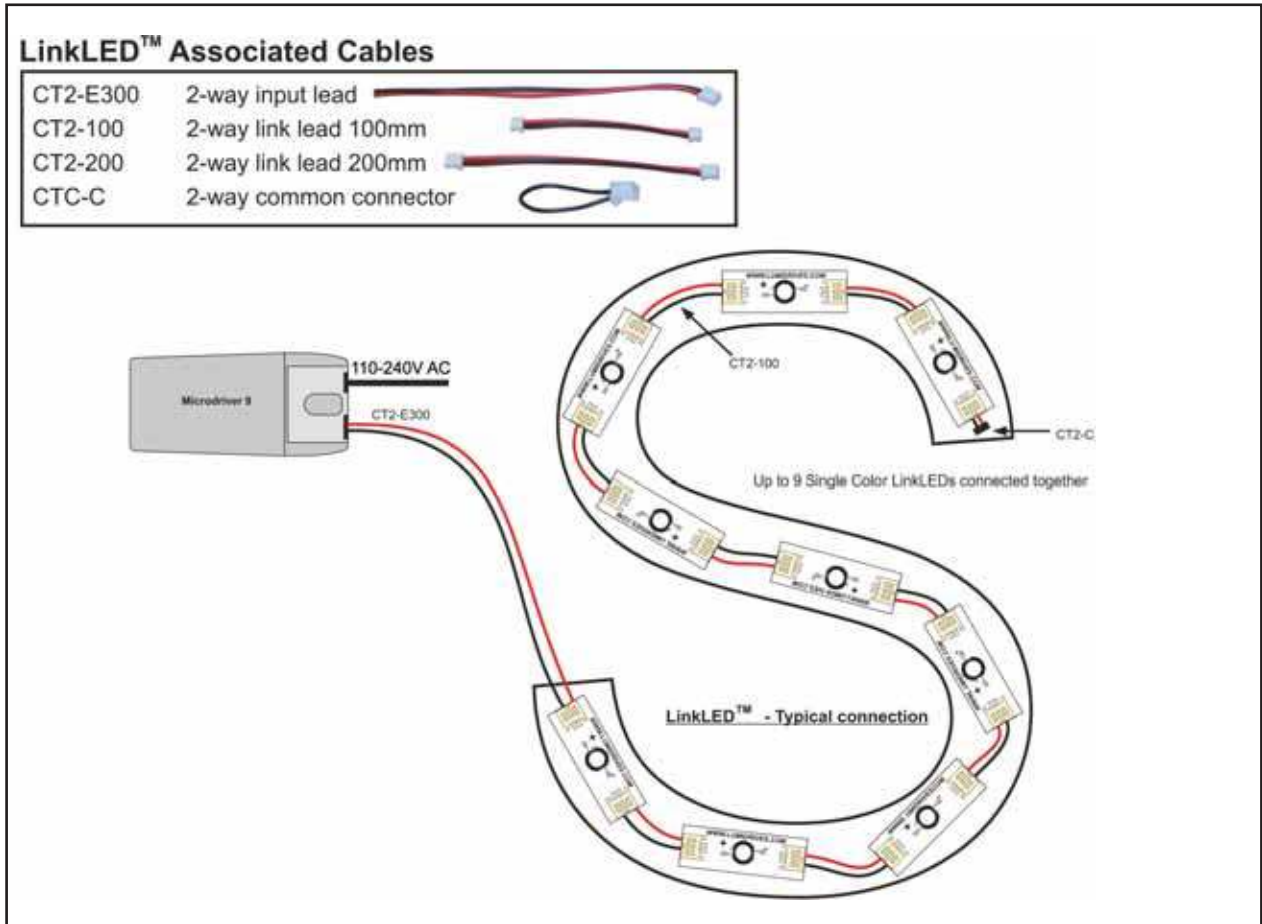

## TYPICAL LED PHOTOMETRIC DATA

LED	Color	Forward Voltage (Typ)	Max. Current (mA)	Max. Power (Watts)	Dom Wavelength / CCT			Min Luminous Flux (lm) / Radiometric Power (mW)	Typ Luminous Flux (lm) / Radiometric Power (mW)
					Min	Typ	Max		
	Red	2.95	350	1.03	620.5 nm	627 nm	645 nm	30.6 lm	44 lm
	Green	3.42	350	1.20	520 nm	530 nm	550 nm	30.6 lm	53 lm
	Royal Blue	3.42	350	1.20	440 nm	455 nm	460 nm	145 mW	220 mW
	Cool White	3.42	350	1.20	4500 K	5500 K	10000 K	30.6 lm	45 lm
	Amber	2.95	350	1.03	584.5 nm	590 nm	597 nm	23.5 lm	42 lm
	W White	3.42	350	1.20	2850 K	3300 K	3800 K	13.9 lm	20 lm

Maximum current input 350mA  
 Maximum power consumption 1.2W per LED for White / Blue / Green / Warm White, 1.0W per LED for Red / Amber.

Results are LED manufacturer's test data @ 25°C JTC. Light output at 55°C PCB temperature will be approximately 15-20% lower. Elevated temperatures will result in further degradation of light output. For maximum performance use appropriate heat sinking.

Dialight reserves the right to make changes at any time in order to supply the best product possible.

**Dialight Corporation**  
 1501 Route 34 South • Farmingdale, NJ 07727 USA  
 Tel: (1) 732-919-3119 • Fax: (1) 732-751-5778 • www.dialight.com

