

170 mA 13 V, high efficiency boost converter + LDO

Datasheet - production data

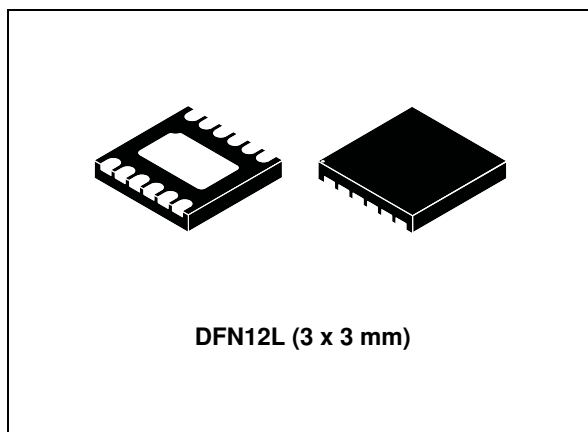

Description

The STOD1317B is a fixed frequency, high efficiency, boost DC-DC converter with cascaded LDO able to provide output voltages ranging from 6 V to 13 V starting with an input voltage from 2.6 V to 4.8 V. The device is designed to supply loads that are very sensitive to output ripple such as AMOLED display panels. A dedicated LDO is able to suppress any ripple and noise coming out from the DC-DC converter. The LDO works with a constant drop in order to maintain high efficiency in the whole operating range. The low R_{DSon} N-channel and P-channel MOSFET switches are integrated and contribute to achieving high efficiency. The true-shutdown feature allows physical disconnection of the battery from the load when the device is in shutdown mode. The control technique is able to maintain efficiency higher than 85% at light loads and higher than 80% at full load. The device includes soft-start control, inrush current limiter, thermal shutdown and inductor peak current limit. The STOD1317B is packaged in DFN12L (3 x 3 x 0.8 mm) height.

Features

- Operating input voltage range from 2.6 V to 4.8 V
- $\pm 1\%$ output voltage tolerance
- Low output ripple
- True-shutdown
- Short-circuit protection
- Digital low power function
- Very high efficiency at light load thanks to pulse skipping operation
- Very fast line and load transients
- 1.2 MHz switching frequency
- 1 μ A max. quiescent current
- DFN12L (3 x 3 x 0.8 mm)

Applications

- Single rail AMOLED display
- Cellular phones
- Battery powered equipment

Table 1. Device summary

Order code	Marking	Package	Packaging
STOD1317BTPUR	1317B	DFN12L (3 x 3 mm)	3000 parts per reel

Contents

1	Schematic	3
2	Pin configuration	5
3	Maximum ratings	6
4	Electrical characteristics	7
5	Typical performance characteristics	9
6	Detailed description	11
6.1	BOOST multiple mode of operation	11
6.1.1	Pulse skipping operation	11
6.1.2	Discontinuous conduction mode	11
6.1.3	Continuous conduction mode	12
6.2	Enable pin	12
6.3	Soft-start and inrush current limiting	12
6.4	Undervoltage lockout	12
6.5	Overtemperature protection	12
6.6	Digital low power function	12
7	Application information	14
7.1	External passive components	14
7.1.1	Inductor selection	14
7.1.2	Input and output capacitor selection	14
7.2	Recommended PCB layout	14
8	Package mechanical data	17
9	Revision history	21

1 Schematic

Figure 1. Application schematic

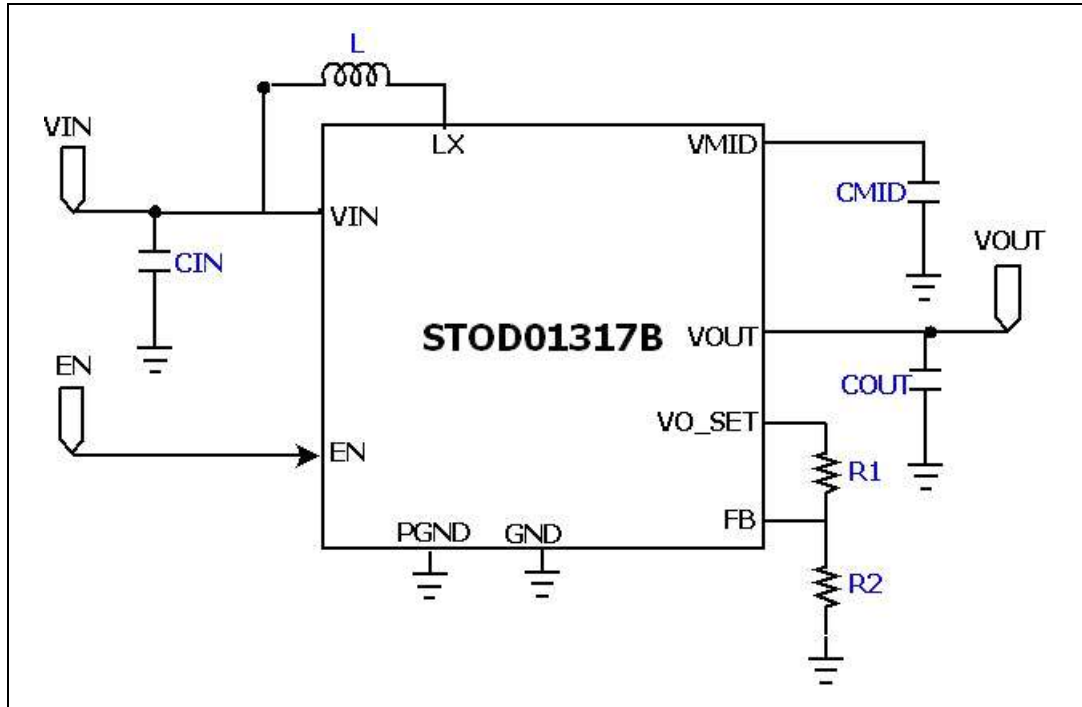

Table 2. Typical external components

Comp.	Manufacturer	Part number	Value	Ratings	Size
C _{IN}	MURATA	GRM219R61A106KE44	10µF	±10%, X5R, 10V	0805
	Taiyo Yuden	LMK212BJ106KD-T		±10%, X5R, 10V	0805
	TDK	C1608X5R0J106		±10%, X5R, 6.3V	0603
C _{MID}	MURATA	GRM219R61C475KE15	4.7µF	±10%, X5R, 16V	0805
	TDK	C2012X5R1C475		±10%, X5R, 16V	0805
C _{OUT}	MURATA	GRM219R61C475KE15	4.7µF	±10%, X5R, 16V	0805
	TDK	C2012X5R1C475		±10%, X5R, 16V	0805
L ⁽¹⁾	CoilCraft	LPS4012-472ML	4.7µH	±20%, curr. 1.7A, resist. 0.175Ω	4.0 x 4.0 x 1.2
	TDK	VLS252012T-4R7MR81		±20%, curr. 1.3A, resist. 0.338Ω	2.5 x 2.0 x 1.2
	DASTEK	PNL3008-4R7M		±20%, curr. 0.9A, resist. 0.280Ω	3.1 x 3.1 x 0.8
R1			kΩ		0402
R2			kΩ		0402

1. Inductor used for the typical application conditions. Inductance values ranging from 3.3 µH to 6.8 µH can be used together with the STOD1317B. A minimum saturation current of 1.2 A must be ensured to support 170 mA at 2.6 V in full range.

Note: All the above components refer to a typical application. Operation of the device is not limited to the choice of these external components.

Figure 2. Block schematic

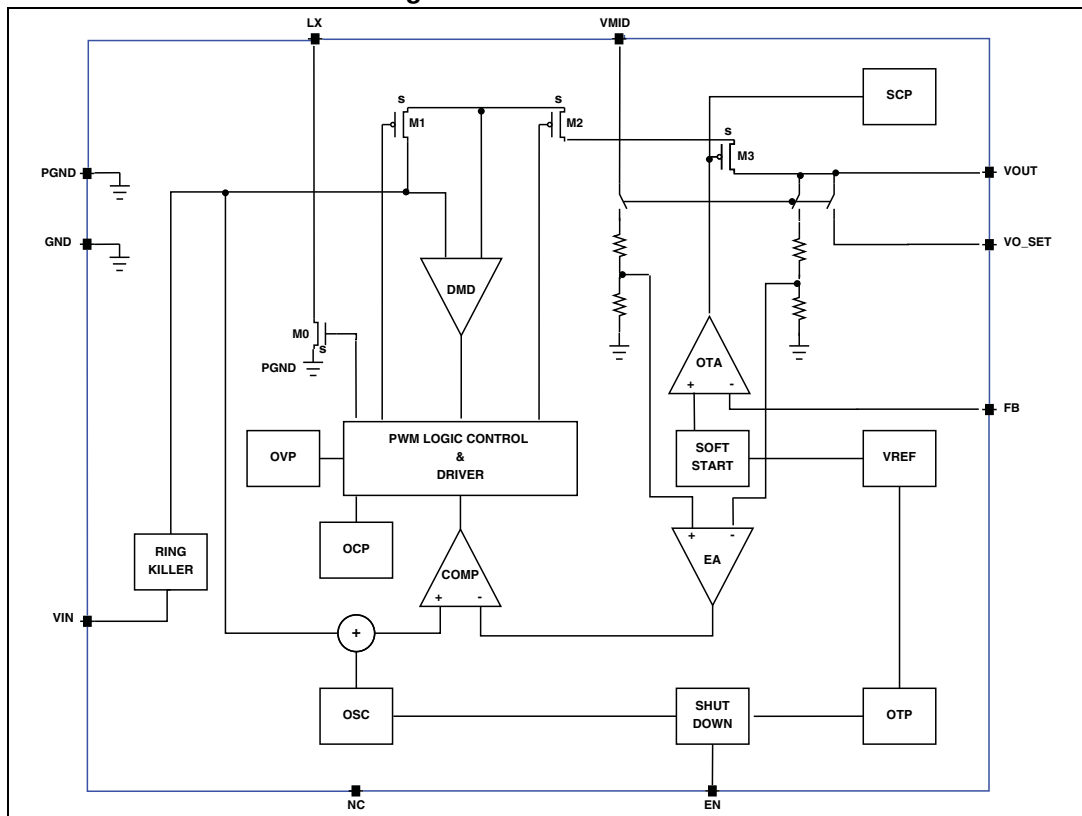

2 Pin configuration

Figure 3. Pin configuration (top view)

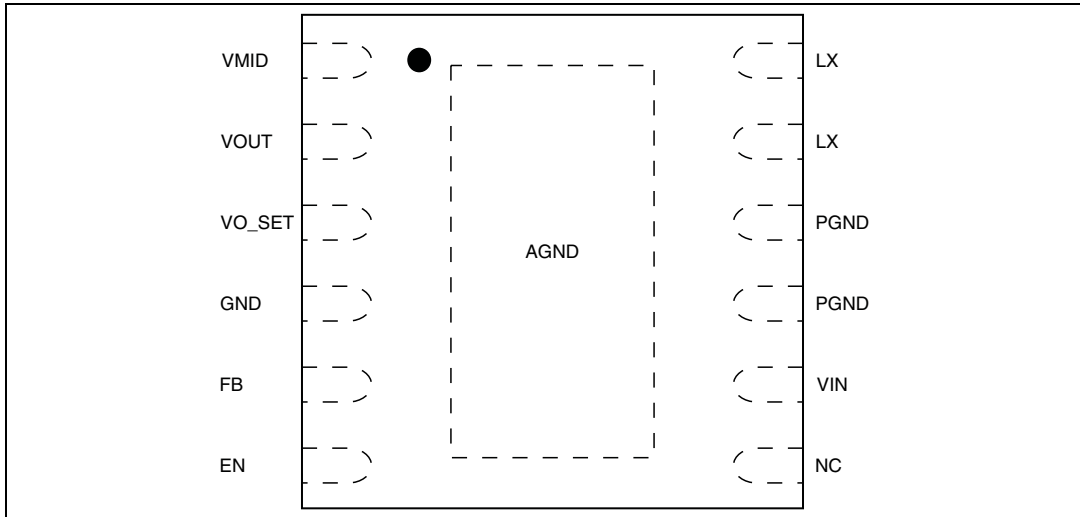

Table 3. Pin description

Pin name	Pin number	Description
VMID	1	Step-up output voltage
VOUT	2	LDO output voltage
VO_SET	3	LDO output voltage set
GND	4	Analog ground
FB	5	Feedback voltage
EN	6	Enable pin. Connect this pin to GND or a voltage lower than 0.4V to shut down the IC. A voltage higher than 1.2V is required to enable the IC
NC	7	Not connected
VIN	8	Supply voltage
PGND	9, 10	Power ground
LX	11, 12	Switch pin. Inductor connection to the internal switches
Exposed PAD		Internally connected to PGND

3 Maximum ratings

Table 4. Absolute maximum ratings

Symbol	Parameter	Value	Unit
V_{IN}	Supply voltage	-0.3 to +7.0	V
LX	Switching node	-0.3 to +16	V
V_{OUT_SET}	LDO output voltage set	16	V
V_{OUT}	Output voltage	-0.3 to +16	V
EN	Logic pin	-0.3 to 4.6	V
FB	Feedback pin	-0.3 to +2.5	V
ESD	Machine model	±200	V
	Human body model	±2000	V
T_{AMB}	Operating ambient temperature	-40 to 85	°C
T_J	Maximum operating junction temperature	+150	°C
T_{STG}	Storage temperature	-65 to 150	°C

Note: Absolute maximum ratings are those values beyond which damage to the device may occur. Functional operation under these conditions is not implied.

Table 5. Thermal data

Symbol	Parameter	Value	Unit
R_{thJA}	Thermal resistance junction-ambient	49.1	°C/W
R_{thJC}	Thermal resistance junction-case (FR-4 PCB)	4.216	°C/W

4 Electrical characteristics

$T_J = 25\text{ }^\circ\text{C}$, $V_{IN} = 3.7\text{ V}$, $V_{OUT} = 10\text{ V}$, $C_{IN} = 2 \times 10\text{ }\mu\text{F}$, $C_{MID} = 2 \times 4.7\text{ }\mu\text{F}$, $C_{OUT} = 2 \times 4.7\text{ }\mu\text{F}$, $L = 4.7\text{ }\mu\text{H}$, $V_{EN} = 2\text{ V}$, unless otherwise specified.

Table 6. Electrical characteristics

Symbol	Parameter	Test conditions	Min.	Typ.	Max.	Unit
General section						
V_{IN}	Operating power input voltage range		2.6	3.7	4.8	V
I_q	Shutdown mode	Shutdown mode, $V_{EN}=\text{GND}$		0.5	1	μA
	No switching	$V_{EN}=V_{IN}=3.7\text{V}$, $V_{FB}=1.3\text{V}$		1	1.5	mA
V_{UVLO}	Undervoltage lockout threshold	V_{IN} rising		2.4	2.5	V
		V_{IN} falling	2.1	2.2		
f_{SW}	Switching frequency		1	1.2	1.35	MHz
I_{PK}	Switch current limitation		1.6	2	2.4	A
Output voltage (V_{OUT})						
V_{FB}	Feedback voltage	$T_A=25^\circ\text{C}$	1.08	1.2	1.32	V
ΔV_{FB}	Accuracy	$-40^\circ\text{C} < T_A < 85^\circ\text{C}$	1.02		1.38	V
V_{OUT}	Output voltage range		6	10	13	V
$\Delta V_{LINE/LOAD}$	Total line/load static variation ⁽¹⁾	$T_A=25^\circ\text{C}$; $V_{IN}=2.6\text{V}$ to 4.8V ; $I_{OUT}=5\text{mA}$ to 170mA		30	40	mV
V_{OUT} RIPPLE	Output voltage ripple	$V_{IN}=3.7\text{V}$, $V_{OUT}=10\text{V}$, $I_{OUT}=10\text{mA}$			30	mV
V_{OVP}	Overvoltage protection	$V_{FB}=0$	14	15	16	V
I_{LKFB}	FB pin leakage current	$V_{FB}=5\text{V}$ to 13V			1	μA
V_{MID}	Step-up output voltage regulation		$V_{OUT} + 0.38$	$V_{OUT} + 0.56$	$V_{OUT} + 0.7$	V
Logic inputs						
V_{IL}	EN low-level input voltage				0.4	V
V_{IH}	EN high-level input voltage		1.2			V
I_{LK-I}	EN input leakage current	$V_{EN}=V_{IN}=4.8\text{V}$			1	μA
Power switches						
$R_{DS(ON)}$	P-Channel ON resistance	$I_{SW_P}=100\text{mA}$		550	900	$\text{m}\Omega$
	N-Channel ON resistance	$I_{SW_N}=100\text{mA}$		250	400	
I_{LKG-LX}	LX leakage current	$V_{IN}=V_{LX}=4.8\text{V}$; $V_{EN}=0$			1	μA

Table 6. Electrical characteristics (continued)

Symbol	Parameter	Test conditions	Min.	Typ.	Max.	Unit
DLP function						
I_{O_LEAK}	Leakage current from load	$V_{IN}=3.7V$, $V_{EN}=0$, $V_{OUT}=6V$ (supplied by external power)		0.5	2	μA

1. Not tested in production. This value is guaranteed by correlation with $R_{DS(ON)}$, peak current limit and operating input voltage.
2. Not tested in production.

5 Typical performance characteristics

$T_J = 25\text{ }^\circ\text{C}$, $V_{IN} = 3.7\text{ V}$, $V_{OUT} = 10\text{ V}$, $C_{IN} = 2 \times 10\text{ }\mu\text{F}$, $C_{MID} = 2 \times 4.7\text{ }\mu\text{F}$, $C_{OUT} = 2 \times 4.7\text{ }\mu\text{F}$, $L = 4.7\text{ }\mu\text{H}$, $V_{EN} = 2\text{ V}$, unless otherwise specified.

Figure 4. Quiescent current vs. temperature

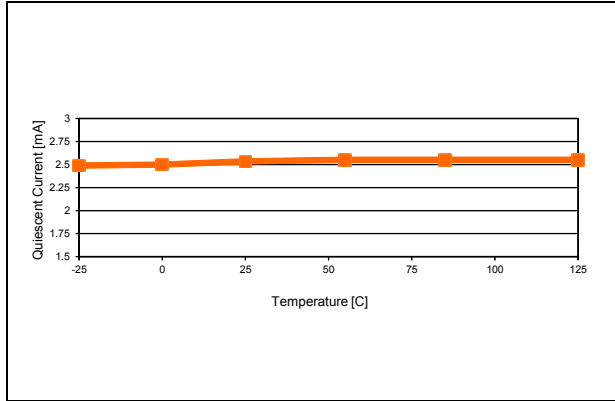

Figure 5. Switching frequency vs. temperature

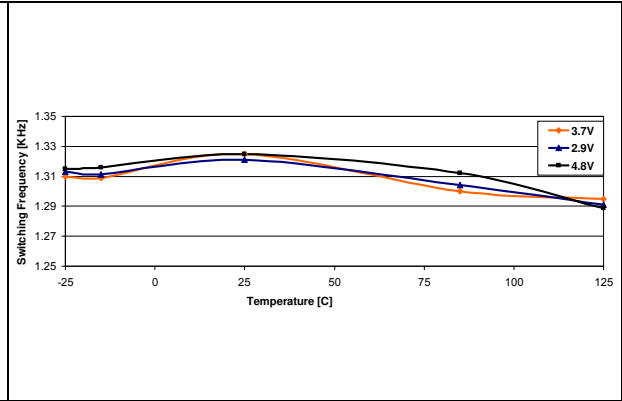

Figure 6. Efficiency vs. output current

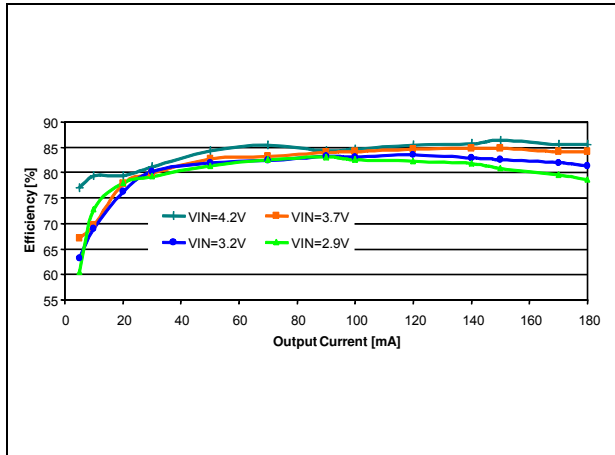

Figure 7. Switching frequency

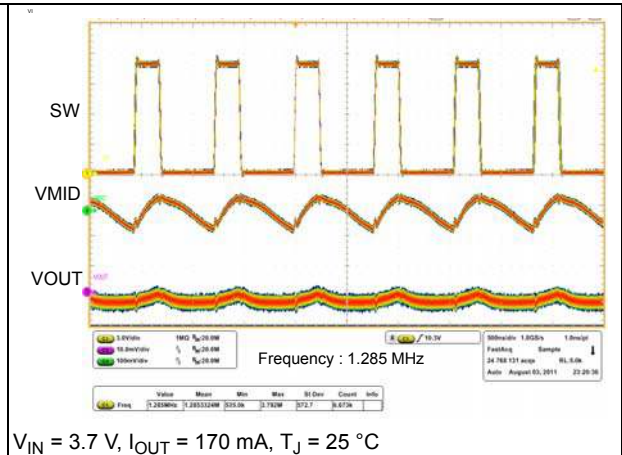

Figure 8. Soft-start inrush current

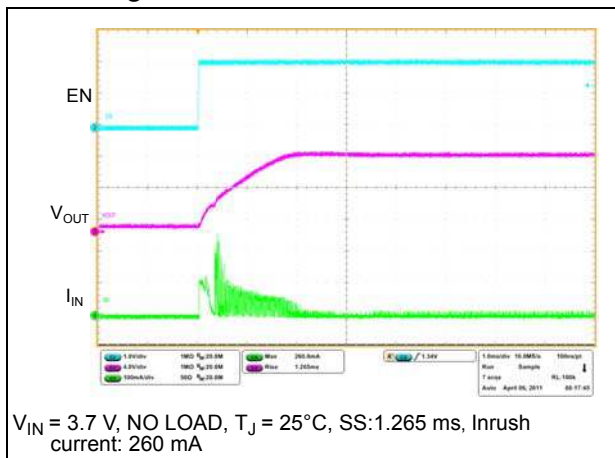

Figure 9. Feedback voltage vs. temperature

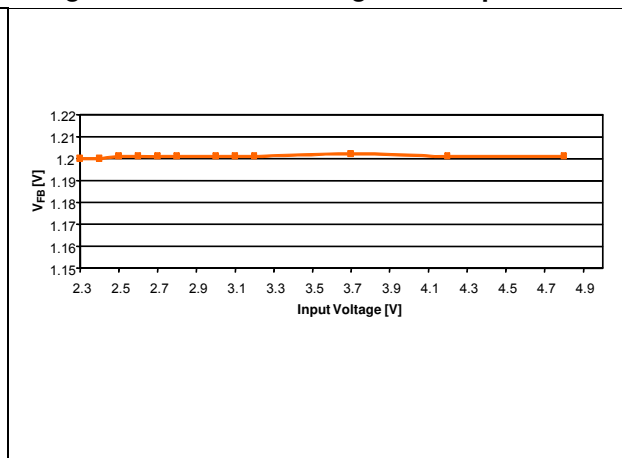
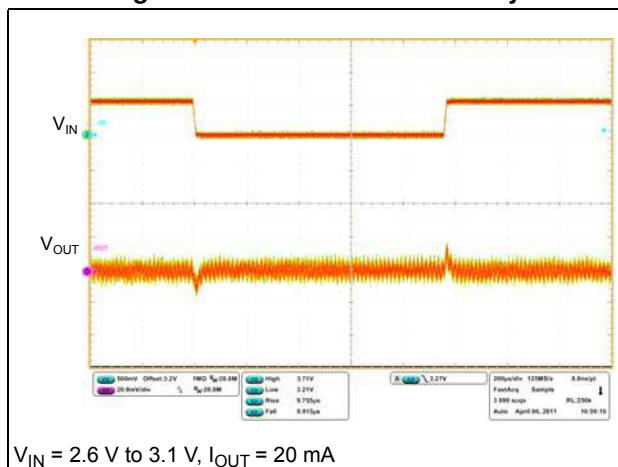

Figure 10. TDMA noise immunity



$V_{IN} = 2.6\text{ V to }3.1\text{ V}$, $I_{OUT} = 20\text{ mA}$

6 Detailed description

The STOD1317B is a high efficiency DC-DC converter which integrates a step-up and LDO power stage suitable for supplying AMOLED panels. Thanks to the high level of integration it needs only 6 external components to operate and it achieves very high efficiency using a synchronous rectification technique.

The controller uses an average current mode technique in order to obtain good stability and precise voltage regulation in all possible conditions of input voltage, output voltage and output current. In addition, the peak inductor current is monitored in order to avoid saturation of the coils.

The STOD1317B implements a power saving technique in order to maintain high efficiency at very light load and it switches to PWM operation as the load increases in order to guarantee the best dynamic performances and low noise operation.

In order to guarantee very low ripple on the output voltage, the step-up output is filtered by the LDO. There are two control loops; the LDO control loop regulates V_{OUT} in order to provide the right voltage to the output, while the boost control loop is internally set to provide and output voltage 380 mV higher than V_{OUT} in order to maintain the LDO in regulation at the minimum possible drop.

The STOD1317B avoids battery leakage thanks to the true-shutdown feature and it is self protected from overtemperature and short-circuit on the V_{OUT} pin. Undervoltage lockout and soft-start guarantee proper operation during startup.

6.1 BOOST multiple mode of operation

The boost DC-DC operates in three different modes: pulse skipping (PS), discontinuous conduction mode (DCM) and continuous conduction mode (CCM). It switches automatically between the three modes according to input voltage, output current and output voltage conditions.

6.1.1 Pulse skipping operation

The STOD1317B works in pulse skipping mode when the load current is below some tens of mA. The load current level at which this way of operation occurs depends on the input and output voltage.

6.1.2 Discontinuous conduction mode

When the load increases above some tens of mA, the STOD1317B enters DCM operation.

In order to obtain this type of operation the controller must avoid the inductor current going negative. The discontinuous mode detector (DMD) block senses the voltage across the synchronous rectifier and turns off the switch when the voltage crosses a defined threshold which, in turn, represents a certain current in the inductor. This current can vary according to the slope of the inductor current which depends on input voltage, inductance value, and output voltage.

6.1.3 Continuous conduction mode

At medium/high output loads the STOD1317B enters full CCM at constant switching frequency mode.

6.2 Enable pin

The device operates when the EN pin is set high. If the EN pin is set low, the device stops switching, all the internal blocks are turned off. In this condition the current drawn from V_{IN} is below 1 μA in the whole temperature range. In addition, the internal switches are in OFF state so the load is electrically disconnected from the input, this avoids unwanted current leakage from the input to the load.

6.3 Soft-start and inrush current limiting

After the EN pin is pulled high, or after a suitable voltage is applied to V_{IN} and EN, the device initiates the startup phase.

As a first step, the C_{MID} capacitor is charged, the P1 switch implements a current limiting technique in order to keep the charge current below 400 mA. This avoids battery overloading during startup.

After V_{MID} reaches the V_{IN} voltage level, the P1 switch is fully turned on and the soft-start procedure for the step-up is started. V_{OUT} starts to softly increase until it reaches the regulation value.

6.4 Undervoltage lockout

The undervoltage lockout function avoids improper operation of the STOD1317B when the input voltage is not high enough. When the input voltage is below the UVLO threshold the device is in shutdown mode. The hysteresis of 100 mV avoids unstable operation when the input voltage is close to the UVLO threshold.

6.5 Overtemperature protection

An internal temperature sensor continuously monitors the IC junction temperature. If the IC temperature exceeds 150 $^{\circ}\text{C}$, typical, the device stops operating. As soon as the temperature falls below 135 $^{\circ}\text{C}$, typical, normal operation is restored.

6.6 Digital low power function

The digital low power (DLP) function allows physical disconnection of the load from the device.

Figure 11. Digital low power function

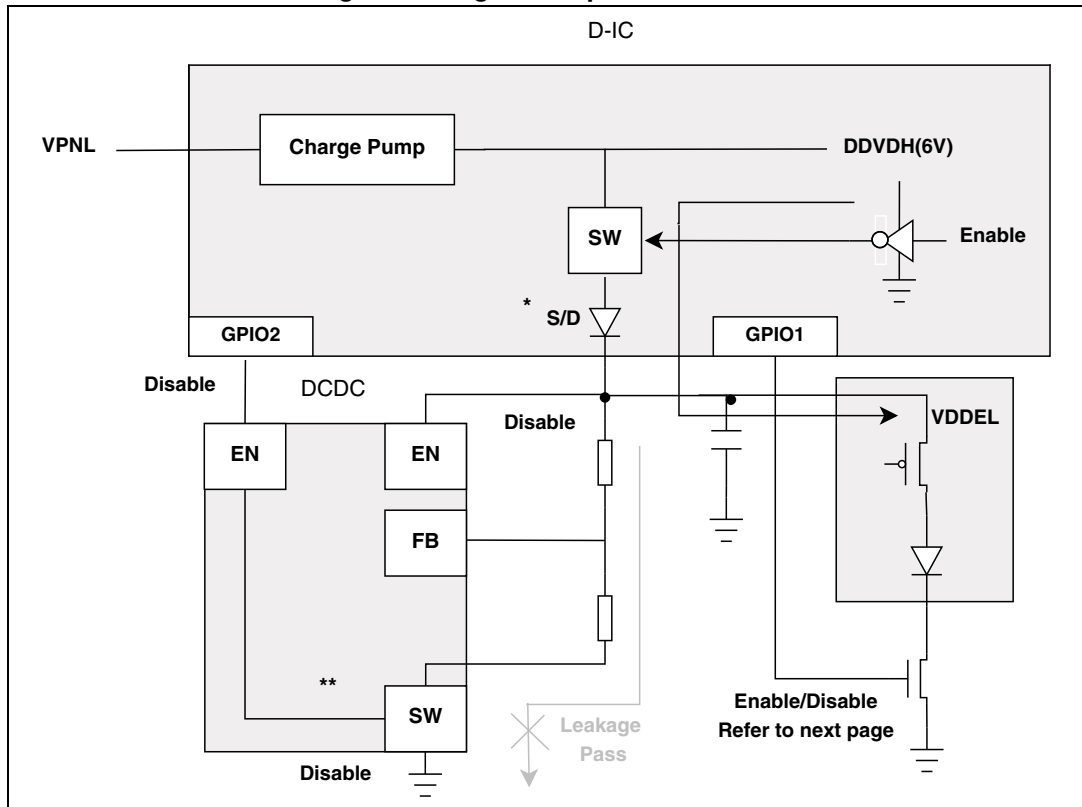

Operation

- (*) When the power IC is disabled, in order to disconnect leakage current through the feedback node, the S/W function is active.
- (**) A new EN transition from low to high and/or device power-up turn off the DLP function and allow IC to work under typical conditions.

7 Application information

7.1 External passive components

7.1.1 Inductor selection

The inductor is the key passive component for switching converters.

For the step-up converter an inductance between 3.3 μH and 6.8 μH is recommended.

It is very important to select the right inductor according to the maximum current the inductor can handle in order to avoid saturation. The peak current for the step-up can be calculated as:

Equation 1

$$I_{\text{PEAK BOOST}} = \frac{V_{\text{MID}} \times I_{\text{OUT}}}{\eta \times V_{\text{INMIN}}} + \frac{V_{\text{INMIN}} \times (V_{\text{MID}} - V_{\text{INMIN}})}{2 \times V_{\text{MID}} \times f_{\text{s}} \times L}$$

where

V_{MID} : step-up output voltage, it is fixed internally to $V_{\text{OUT}} + 0.38 \text{ V}$;

I_{OUT} : output current;

V_{IN} : input voltage of the STOD1317B;

f_{s} : switching frequency. Use the minimum value of 1 MHz for worst case;

η : efficiency of the step-up converter (0.80 at maximum load).

7.1.2 Input and output capacitor selection

It is recommended to use ceramic capacitors with low ESR as input and output capacitors in order to filter any disturbance present in the input line and to obtain stable operation of the step-up converter and LDO. A minimum real capacitance value of 3 μF must be guaranteed for C_{MID} and C_{OUT} in all conditions.

7.2 Recommended PCB layout

The STOD1317B is a high frequency power switching device so it requires a proper PCB layout in order to obtain the necessary stability and optimize line/load regulation and output voltage ripple.

The input capacitor must be as close as possible to the V_{IN} pin.

In order to minimize the ground noise, a common ground node for power ground (PGND) and a different one for analog ground (GND) must be used. The exposed pad is connected to PGND through vias.

Grounding is fundamental to the operation of DC-DC converters; run separate ground paths for critical parts of the circuit (GND and Power GND), each connected back to a single ground point.

Separate ground lines prevent the current and noise of one component from interfering with other components. If using a ground plane, utilize "split" plane techniques to give effective grounding. Use multiple vias to decrease the trace impedance to ground.

Figure 12. Ground schematic

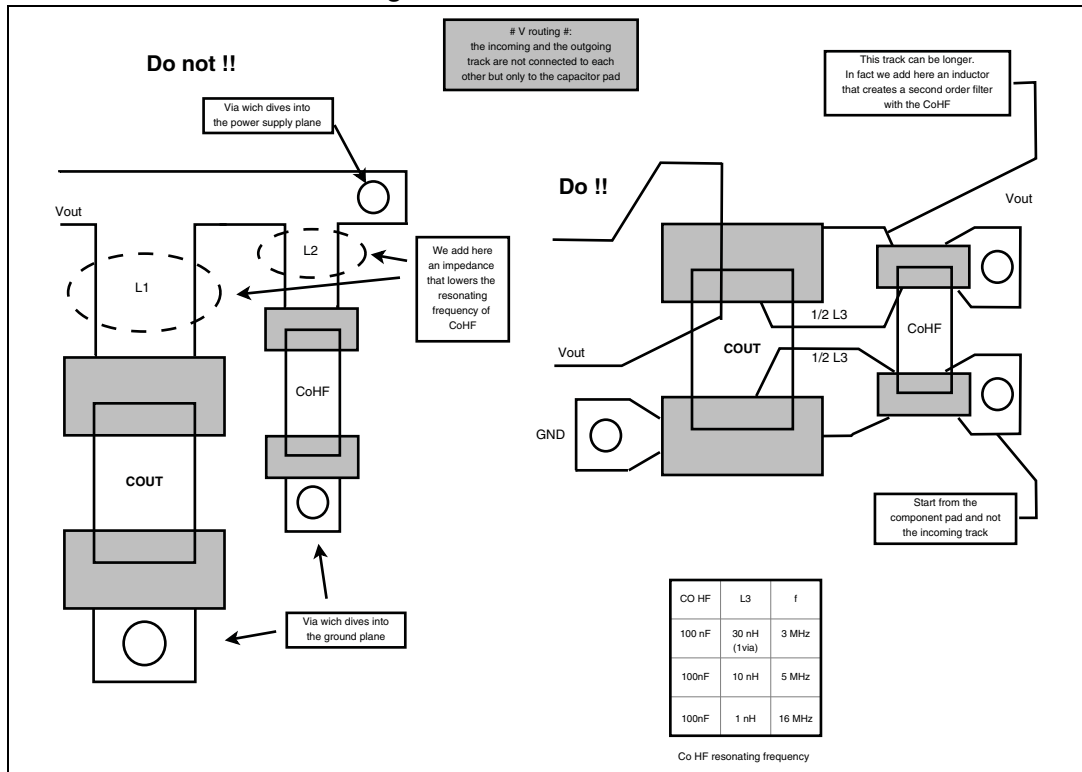

Such isolation is necessary to prevent high-level switching currents from returning to the battery, or other power supply, through the same ground-return path as the analog signals.

If that happens, the ground path of those sensitive signals is disturbed; the high-level switching currents flowing through the ground's resistance and inductance cause the voltage along the return path to vary.

In addition to the grounding scheme, proper placement of the regulator's components is important.

Beginning a new layout, for the reasons above, it is necessary to firstly place the capacitors C_{IN} , C_{OUT} and C_{MID} as close as possible to the related device pins.

After that, it is possible to place the inductors and the Power GND routing. Next, we can trace the GND connected through vias to the PGND near to one of the main filter capacitors.

The LDO needs a quiet ground signal in order to operate properly.

It is important to pay close attention to the routing of traces from capacitor terminals in a DC-DC converter circuit.

Large-valued low-ESR capacitors are expensive, and bad routings can cancel their performance.

A good routing, on the other hand, can lower the output noise.

Ripple is directly related to the inductor value, the capacitor ESR, the switching frequency, and so forth, but HF noise (spikes) depends on parasitic elements and the switching action. In a bad routing, parasitic inductance associated with trace lengths causes problems: In [Figure 12](#), L1 brings about an increase in noise, and L2 limits the attenuation of an added HF capacitor. The solution is to bring the input trace in on one side of the capacitor pad, and the output trace out on the other side of the pad.

Figure 13. Top layer

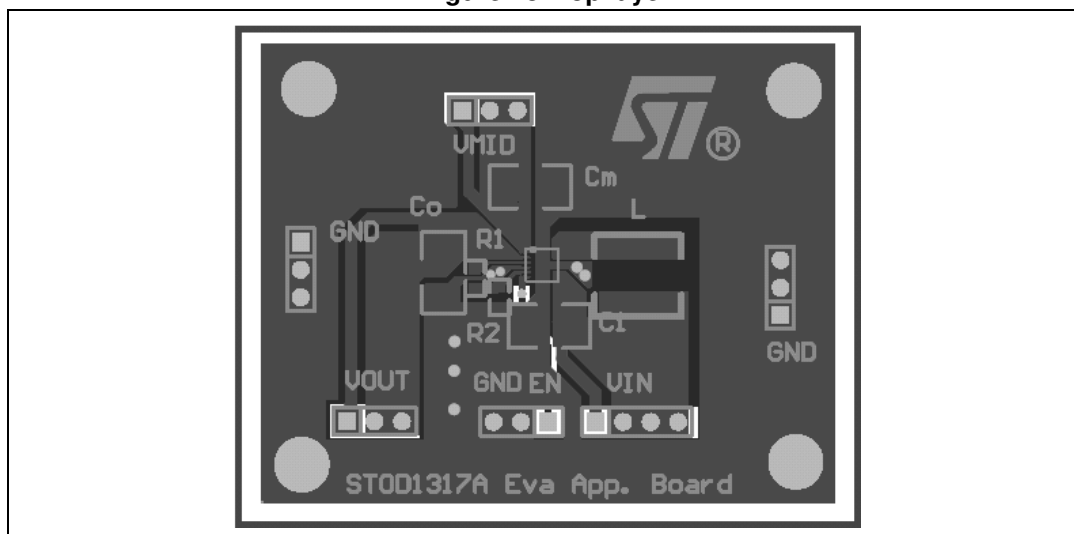
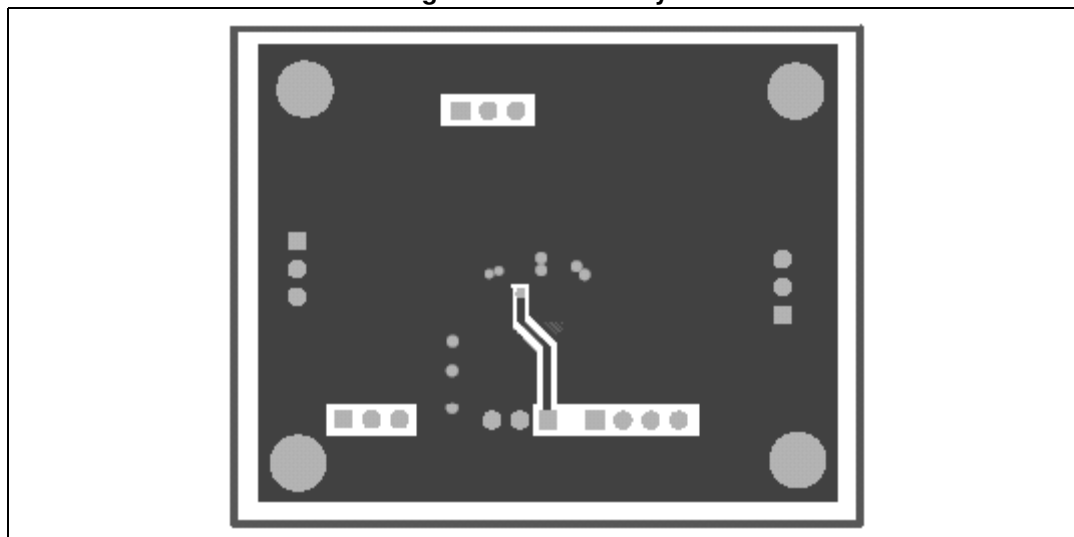

Figure 14. Bottom layer



8 Package mechanical data

In order to meet environmental requirements, ST offers these devices in different grades of ECOPACK[®] packages, depending on their level of environmental compliance. ECOPACK[®] specifications, grade definitions and product status are available at: www.st.com. ECOPACK[®] is an ST trademark.

Table 7. DFN12L (3 x 3 x 0.8 mm.) package mechanical data

Dim.	mm.		
	Min.	Typ.	Max
A	0.70	0.75	0.80
A1	0	0.02	0.05
A3		0.20	
b	0.18	0.25	0.30
D	2.85	3	3.15
D2	1.87	2.02	2.12
E	2.85	3	3.15
E2	1.06	1.21	1.31
e		0.45	
L	0.30	0.40	0.50

Figure 15. DFN12L package dimensions

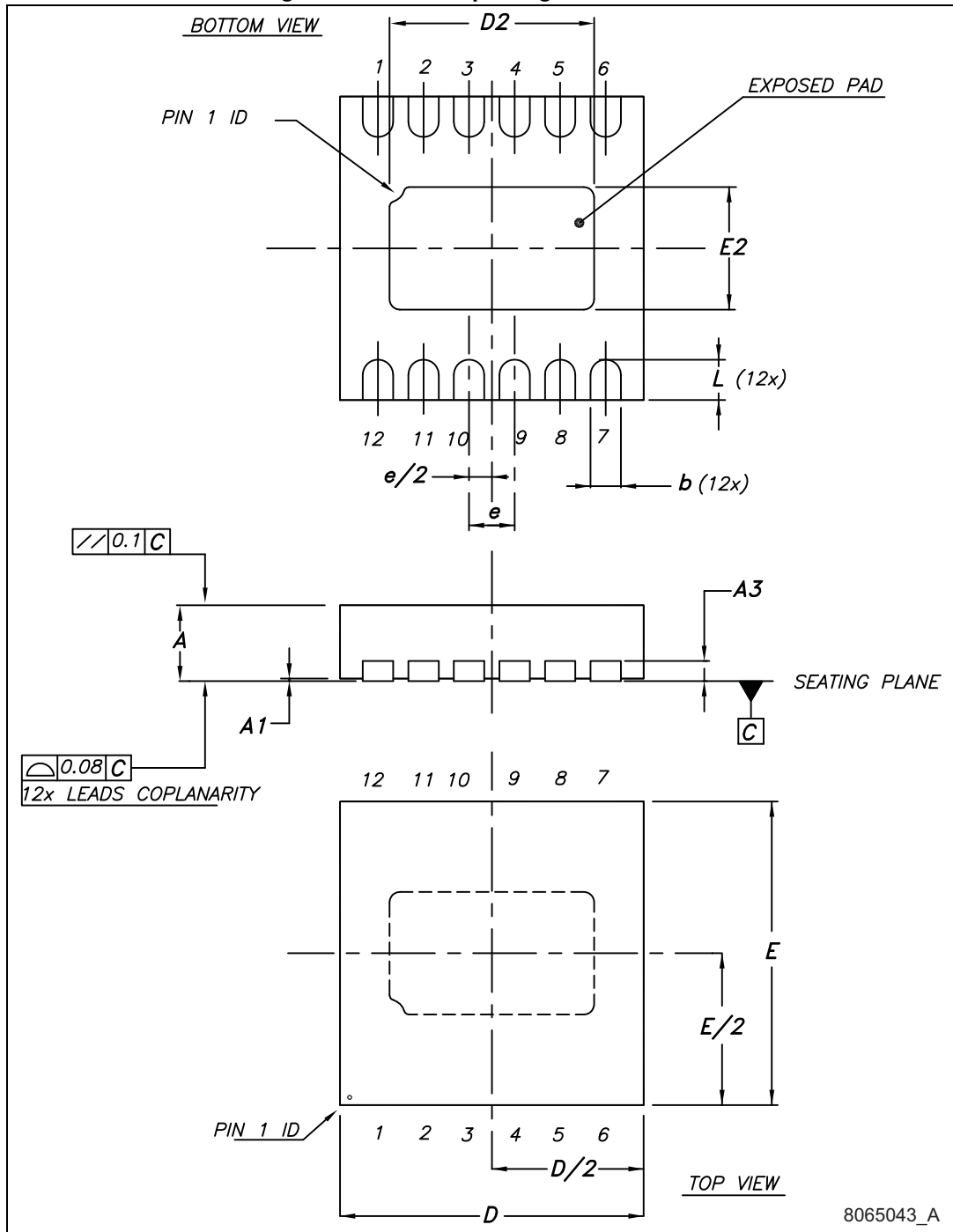

Tape & reel QFNxx/DFNxx (3x3) mechanical data

DIM.	mm.			inch		
	MIN.	TYP	MAX.	MIN.	TYP.	MAX.
A			330			12.992
C	12.8		13.2	0.504		0.519
D	20.2			0.795		
N	99		101	3.898		3.976
T			14.4			0.567
Ao		3.3			0.130	
Bo		3.3			0.130	
Ko		1.1			0.043	
Po		4			0.157	
P		8			0.315	

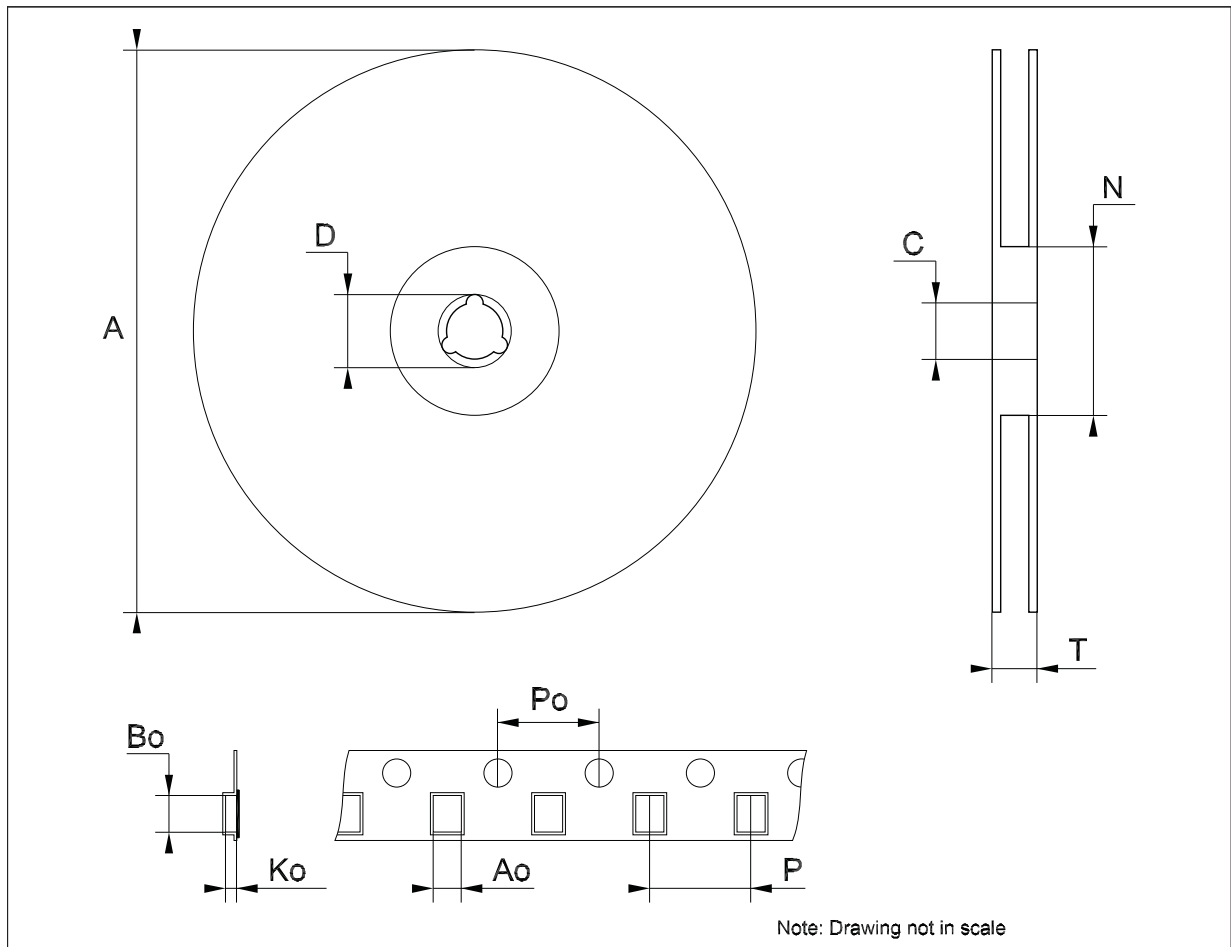
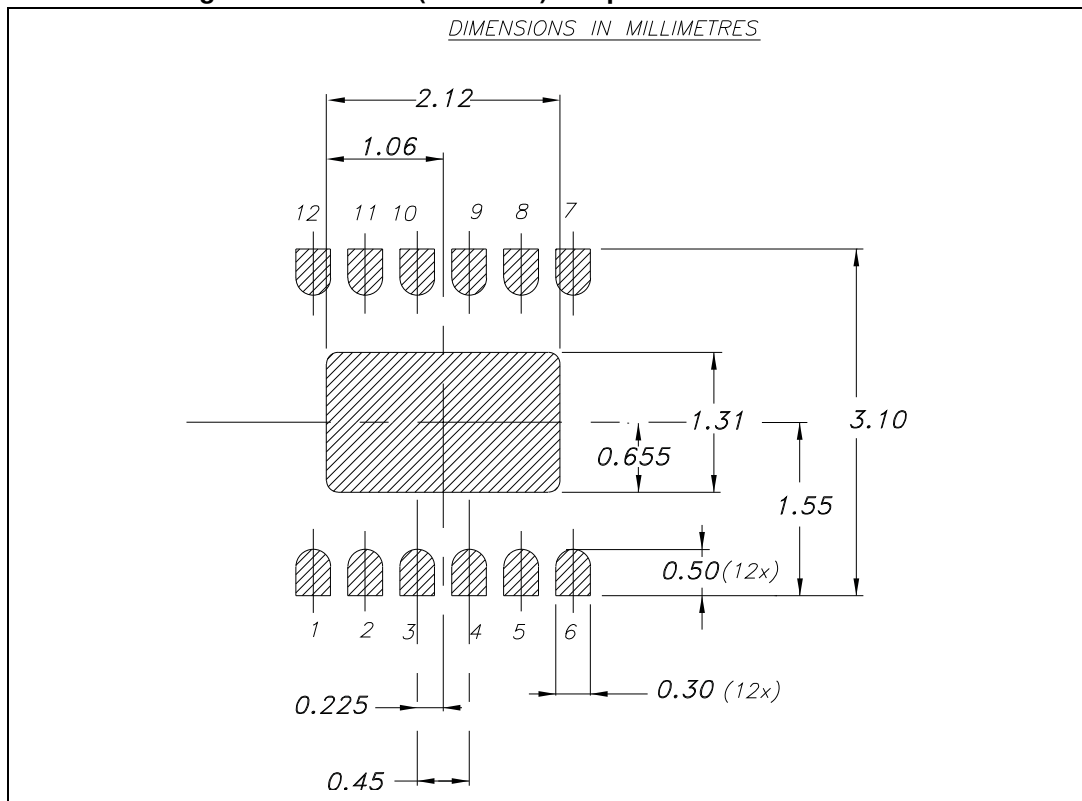

Figure 16. DFN12L (3 x 3 mm) footprint recommended data



9 Revision history

Table 8. Document revision history

Date	Revision	Changes
19-Dec-2011	1	Initial release.
11-Apr-2013	2	Updated: – Package mechanical data Table 7 on page 17 and Figure 15 on page 18 .

Please Read Carefully:

Information in this document is provided solely in connection with ST products. STMicroelectronics NV and its subsidiaries ("ST") reserve the right to make changes, corrections, modifications or improvements, to this document, and the products and services described herein at any time, without notice.

All ST products are sold pursuant to ST's terms and conditions of sale.

Purchasers are solely responsible for the choice, selection and use of the ST products and services described herein, and ST assumes no liability whatsoever relating to the choice, selection or use of the ST products and services described herein.

No license, express or implied, by estoppel or otherwise, to any intellectual property rights is granted under this document. If any part of this document refers to any third party products or services it shall not be deemed a license grant by ST for the use of such third party products or services, or any intellectual property contained therein or considered as a warranty covering the use in any manner whatsoever of such third party products or services or any intellectual property contained therein.

UNLESS OTHERWISE SET FORTH IN ST'S TERMS AND CONDITIONS OF SALE ST DISCLAIMS ANY EXPRESS OR IMPLIED WARRANTY WITH RESPECT TO THE USE AND/OR SALE OF ST PRODUCTS INCLUDING WITHOUT LIMITATION IMPLIED WARRANTIES OF MERCHANTABILITY, FITNESS FOR A PARTICULAR PURPOSE (AND THEIR EQUIVALENTS UNDER THE LAWS OF ANY JURISDICTION), OR INFRINGEMENT OF ANY PATENT, COPYRIGHT OR OTHER INTELLECTUAL PROPERTY RIGHT.

ST PRODUCTS ARE NOT AUTHORIZED FOR USE IN WEAPONS. NOR ARE ST PRODUCTS DESIGNED OR AUTHORIZED FOR USE IN: (A) SAFETY CRITICAL APPLICATIONS SUCH AS LIFE SUPPORTING, ACTIVE IMPLANTED DEVICES OR SYSTEMS WITH PRODUCT FUNCTIONAL SAFETY REQUIREMENTS; (B) AERONAUTIC APPLICATIONS; (C) AUTOMOTIVE APPLICATIONS OR ENVIRONMENTS, AND/OR (D) AEROSPACE APPLICATIONS OR ENVIRONMENTS. WHERE ST PRODUCTS ARE NOT DESIGNED FOR SUCH USE, THE PURCHASER SHALL USE PRODUCTS AT PURCHASER'S SOLE RISK, EVEN IF ST HAS BEEN INFORMED IN WRITING OF SUCH USAGE, UNLESS A PRODUCT IS EXPRESSLY DESIGNATED BY ST AS BEING INTENDED FOR "AUTOMOTIVE, AUTOMOTIVE SAFETY OR MEDICAL" INDUSTRY DOMAINS ACCORDING TO ST PRODUCT DESIGN SPECIFICATIONS. PRODUCTS FORMALLY ESCC, QML OR JAN QUALIFIED ARE DEEMED SUITABLE FOR USE IN AEROSPACE BY THE CORRESPONDING GOVERNMENTAL AGENCY.

Resale of ST products with provisions different from the statements and/or technical features set forth in this document shall immediately void any warranty granted by ST for the ST product or service described herein and shall not create or extend in any manner whatsoever, any liability of ST.

ST and the ST logo are trademarks or registered trademarks of ST in various countries.

Information in this document supersedes and replaces all information previously supplied.

The ST logo is a registered trademark of STMicroelectronics. All other names are the property of their respective owners.

© 2013 STMicroelectronics - All rights reserved

STMicroelectronics group of companies

Australia - Belgium - Brazil - Canada - China - Czech Republic - Finland - France - Germany - Hong Kong - India - Israel - Italy - Japan - Malaysia - Malta - Morocco - Philippines - Singapore - Spain - Sweden - Switzerland - United Kingdom - United States of America

www.st.com