

**FEMALE RIGHT ANGLE RECEPTACLE FOR PCB**

**R123.680.003**

**SOLDER LEGS**

Series : QMA

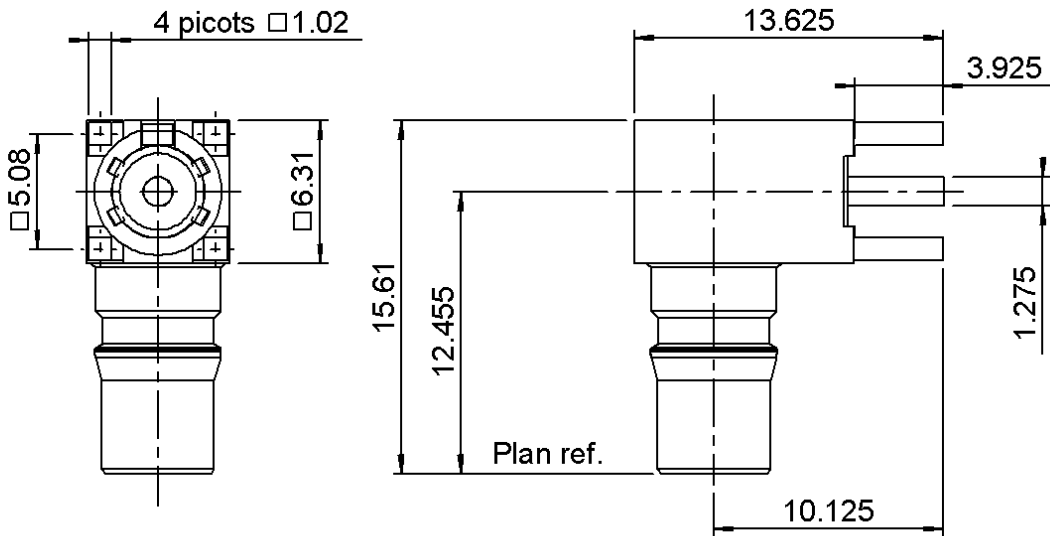

**PANEL CUT OUT**

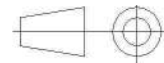
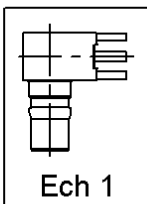
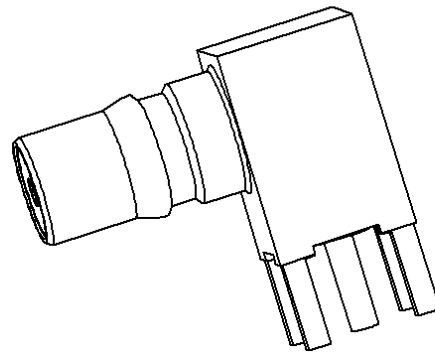
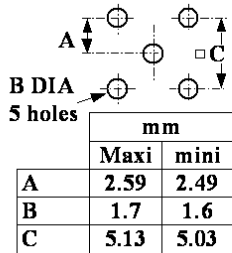

All dimensions are in mm.

COMPONENTS	MATERIALS	PLATING (µm)
BODY	BRASS	NPGR
CENTER CONTACT	BERYLLIUM COPPER	NPGR
OUTER CONTACT	-	-
INSULATOR	PTFE	
GASKET	-	
OTHERS PARTS	BRASS	GOLD 0.2 OVER NICKEL 2
-	-	-
-	-	-

Issue : 0923 D

In the effort to improve our products, we reserve the right to make changes judged to be necessary.



**FEMALE RIGHT ANGLE RECEPTACLE FOR PCB  
SOLDER LEGS**

**R123.680.003**

Series : QMA

**PACKAGING**

**SPECIFICATION**

Standard	Unit	Other
<b>100</b>	<b>'W' option</b>	<b>Contact us</b>

**ELECTRICAL CHARACTERISTICS**

**ENVIRONMENTAL**

Impedance	<b>50</b>	$\Omega$
Frequency	<b>0-6</b>	GHz
VSWR	<b>1.30 + 0,0000</b>	x F(GHz) Maxi
Insertion loss	<b>0.07</b>	$\sqrt{F}(\text{GHz})$ dB Maxi
RF leakage	- ( <b>80</b> )	- F(GHz)) dB Maxi
Voltage rating	<b>500</b>	Veff Maxi
Dielectric withstanding voltage	<b>1000</b>	Veff mini
Insulation resistance	<b>5000</b>	M $\Omega$ mini

Operating temperature	<b>-40/+105</b>	$^{\circ}$ C
Hermetic seal	<b>NA</b>	Atm.cm3/s
Panel leakage	<b>NA</b>	

**OTHER CHARACTERISTICS**

Assembly instruction **NA**

Others :

Intermod.:<-120dBc at 1.8GHz(2 x 20W)  
RF leakage Interf. only: 3<F<6GHz:<-70dB

**MECHANICAL CHARACTERISTICS**

Center contact retention		
Axial force – Mating end	<b>27</b>	N mini
Axial force – Opposite end	<b>27</b>	N mini
Torque	<b>NA</b>	N.cm mini
Recommended torque		
Mating	<b>NA</b>	N.cm
Panel nut	<b>NA</b>	N.cm
Mating life	<b>100</b>	Cycles mini
Weight	<b>3,0000</b>	g

Issue : 0923 D

In the effort to improve our products, we reserve the right to make changes judged to be necessary.

