

PART NUMBER	REVISION	DESCRIPTION	FEED TYPE
2150016-1	L	FINE CRIMP HEIGHT ADJUST	MECHANICAL
2150016-2	M	FINE CRIMP HEIGHT ADJUST	PNEUMATIC
7-2150016-1	L	MECHANICAL AND CRIMP TOOLING KIT	MECHANICAL
7-2150016-2	M	PNEUMATIC AND CRIMP TOOLING KIT	PNEUMATIC
7-2150016-7	H	CRIMP TOOLING KIT	-

ATLANTIC VERSION TERMINATOR INTERFACE ADAPTER

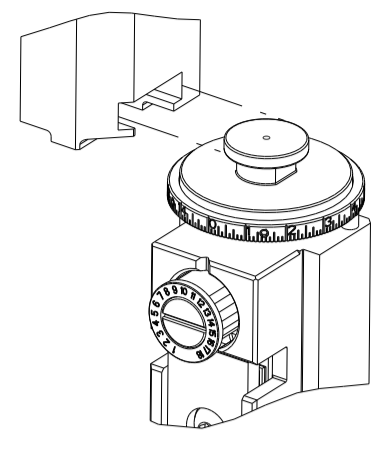

APPLICATOR DATA		
CRIMP	SIZE	TYPE
WIRE	2.79 mm [1.10]	F
INSUL	4.57 mm [1.80]	F
APPLICATOR INSTRUCTIONS 408-35043		

TERMINAL DATA: TE TERMINAL		TE CRIMP SPECIFICATION	
TERMINAL NAME: RECEPTACLE, FASTON .250 SERIES			
WIRE STRIP LENGTH	INSULATION DIAMETER RANGE		
6.00-6.80 mm [1.236-.268 IN]	Ø3.05-4.31 mm [1.20-.170 IN]		
TERMINAL APPLICATION SPECIFICATION	114-2036		
TERMINALS APPLIED			
TE TERMINAL	TE TERMINAL	TE TERMINAL	TE TERMINAL
63306-1	60713-1	42660-1	1217393-1
63306-2	60713-2	42660-2	63985-1
42400-1	350981-2	60650-1	63674-1
42400-2	42219-1	60650-2	1742948-1
42400-3	42219-2	60650-3	1742971-4
1742198-1	154692-1	1217272-1	2238196-3
1742198-2	1742198-4	1742198-5	1742198-6
2-1742198-4	2-1742198-6		

WIRE SIZE	CRIMP HEIGHT mm [INCH]	CRIMP HEIGHT REFERENCE SETTING
14 AWG	1.85+/-0.05 [1.073+/-0.002]	7.5
(1)18 & (1)16	1.85+/-0.05 [1.073+/-0.002]	7.5
(2)18	1.73+/-0.05 [1.068+/-0.002]	9.0
16 OR (1)20 & (1)18	1.63+/-0.05 [1.064+/-0.002]	10.0
18 AWG	1.47+/-0.05 [1.058+/-0.002]	11.7

- RECOMMENDED SPARE PARTS
- REFER TO SUPPLIED INSTRUCTION SHEET FOR CLEANING, LUBRICATION AND STORAGE OF APPLICATOR.
- APPLY PART NUMBER 2-23419-6 LOCTITE TO THREADS OF ITEM 242. APPLY PART NUMBER 1-23419-5 LOCTITE TO THREADS OF ITEM 50.
- CRIMP HEIGHT REFERENCE SETTING WAS THE SETTING USED WHEN THE APPLICATOR WAS QUALIFIED AT THE FACTORY. ADJUSTMENT MAY BE NECESSARY WHEN RUNNING APPLICATOR IN THE FIELD.
- TERMINAL LUBRICANT IS RECOMMENDED.
- 6. UNLESS SPECIFIED OTHERWISE TORQUE VALUES SHALL BE USED PER DOCUMENT, 101-35000.

***WARNING**
ON INSTALLATION, SET WIRE DISC TO CRIMP HEIGHT REFERENCE SETTING FOR LARGEST WIRE SIZE. CRIMP HEIGHT REFERENCE SETTINGS GREATER THAN THE VALUE SHOWN MAY CAUSE DAMAGE TO THE CRIMP TOOLING. REFER TO THE INSTRUCTION SHEET FOR PROPER SETUP AND ADJUSTMENTS.

ATLANTIC VERSION
Shown on sheets 1 of 4 & 2 of 4
(Pacific version shown on sheets 3 of 4 & 4 of 4)

LOC	DIST	REVISIONS					
		P	LTN	DESCRIPTION	DATE	OWN	APVD
A	66	K3		ECR-18-004151	26MAR2018	FL	GB
		L		ECR-18-015547	29SEP2018	TB	TE
		M		ECR-20-014834	19OCT2020	TB	RK
		M1		ECR-22-137520	29APR2022	FZ	JAH

-	1	1	1	1	2079383-5	SCR, BHSC, RoHS (M4 X 20)	261	
-	1	-	1	-	2119641-1	FEED CAM, AIR FEED	248	
-	1	1	1	1	2119082-9	CAM, SNAIL, INSULATION ADJUSTMENT	244	
-	1	1	1	1	2079764-1	WASHER, WAVE SPRING, CREST-TO-CREST	243	
-	1	1	1	1	2119083-1	RETAINER, INSULATION DIAL	242	
-	-	1	-	1	2119580-1	MECHANICAL FEED ASSEMBLY	239	
-	1	-	1	-	2844940-3	AIR FEED MODULE	238	
-	1	1	1	1	1-18028-0	WASHER, FLAT, REG M8	192	
-	1	1	1	1	6-993111-6	PIN, SLOTTED SPRING 3.0 X 14.0	177	
-	1	1	1	1	8-22280-7	SPRING, COMPRESSION	176	
-	1	1	1	1	1752353-2	GUIDE PIN,HOLDDOWN	175	
-	1	1	1	1	1901680-2	GUIDE PIN,HOLDDOWN	174	
-	REF	REF	REF	REF	994970-2	COUNTER, MAGNETIC	164	
-	1	1	1	1	2119955-2	ASSY, LUBRICATOR, END FEED	84	
-	1	1	1	1	455888-4	SPACER, CRIMPER	82	
-	1	1	1	1	1803607-4	DOCUMENTATION PACKAGE	71	
-	2	2	2	2	2-18032-2	SCR, SET, FLT PNT, M3 X 10.0	70	
-	1	1	1	1	2119740-1	TAG,IDENTIFICATION	67	
-	2	2	2	2	2168078-1	SCREW, DRIVE, RH, RoHS, 2 x .188	66	
-	1	1	1	1	1901681-5	HOLDDOWN, TERMINAL	65	
-	2	2	2	2	2168400-5	SHCS, LOW HEAD, RoHS, M4 X 20	64	
-	1	1	1	1	2168083-2	SCR, SKT HD CAP, RoHS, M4 X 8.0	60	
-	1	1	1	1	5-18022-5	SCR, HEX HD CAP, M4 X 6.0	59	
-	-	1	-	1	2063961-1	FEED FINGER	58	
-	3	3	3	3	2168400-4	SHCS, LOW HEAD, RoHS, M4 X 8	57	
-	2	2	2	2	2168083-3	SCR, SKT HD CAP, RoHS, M4 X 12.0	56	
-	2	2	2	2	5018030-1	NUT, HEX, REG, RoHS, M3	54	
-	2	2	2	2	986965-8	NUT, LOCK, HEX, TORQUE (M4)	53	
-	1	1	1	1	1-5018030-0	NUT, HEX, REG, RoHS, M3.5	52	
-	1	-	1	-	2063961-1	FEED FINGER	51	
-	1	1	1	1	1-1752354-4	STANDOFF,HOLD-DOWN	50	
-	1	2	1	2	18023-9	SCR, SKT HD CAP M4 X 6.0	49	
-	-	1	-	1	2119652-1	FEED CAM, PRE FEED	48	
-	-	1	-	1	2119653-1	FEED CAM, POST FEED	47	
-	1	1	1	1	2119655-5	APPLICATOR BASIC ASSEMBLY, EF	46	
-	1	1	1	1	1803517-1	RAM ASSEMBLY, EF ATLANTIC	44	
-	1	1	1	1	1803602-1	SCR, BHSC, RoHS (M8 X 25)	41	
-	7	7	7	7	1-18028-2	WASHER, FLAT, REG M4	33	
-	1	1	1	1	2168400-5	SHCS, LOW HEAD, RoHS, M4 X 20	31	
-	2	2	2	2	2168083-2	SCR, SKT HD CAP, RoHS, M4 X 8.0	29	
-	1	1	1	1	240639-1	STRIPPER (MACHINING)	27	
-	2	2	2	2	1-2168083-5	SCR, SKT HD CAP, RoHS, M4 X 30	25	
-	1	1	1	1	1752371-1	PLATE, STRIP GUIDE	24	
-	1	1	1	1	240825-1	PLATE, STRIP HOLD DOWN	23	
-	2	2	2	2	2-22281-3	SPRING, COMPRESSION	22	
-	1	1	1	1	1803292-4	DRAG	20	
-	2	2	2	2	1901259-6	GUIDE, LOWER STRIP	18	
-	4	4	4	4	1-2079383-1	SCR, BHSC, RoHS (M6 X 12)	17	
-	1	1	1	1	240641-1	SPACER	16	
-	1	1	1	1	1752360-1	SPACER,HOLD-DOWN	13	
-	1	1	1	1	240644-1	PLATE, REAR SHEAR	11	
-	-	-	-	-	-	-	10	
-	1	1	1	1	690495-4	PLATE, FRONT SHEAR	9	
-	1	2	2	1	1	3-1803000-1	ANVIL, COMBINATION, END FEED	8
-	1	1	1	1	1	1-2217206-4	BLADE, SLUG	7
-	1	1	1	1	1	1-240641-6	SPACER	5
-	1	1	1	1	1	238011-2	BLOCK, CRIMPER SPACER	4
-	1	2	2	1	1	2119582-3	CRIMPER, INSULATION F PREMIUM	3
-	1	1	1	1	1	1-455888-0	SPACER, CRIMPER	2
-	1	2	2	1	1	1-1633730-9	CRIMPER, WIRE	1
-	77	72	71	2	-1	PART NO	ITEM NO	

DIMENSIONS:		TOLERANCES UNLESS OTHERWISE SPECIFIED:		MATERIAL:	
mm	0 PLC ±	1 PLC ±	2 PLC ±	3 PLC ±	4 PLC ±
	ANGLES	FINISH			
DWG: B. WEAVER 29NOV2011		CHK: G. HOFFNER 29NOV2011		APVD: T. ELBIN 29NOV2011	
NAME: Ocean End Feed Applicator		SIZE: A1		CAGE CODE: 00779	
DRAWING NO: 2150016		SCALE: 1:1		SHEET 1 OF 4	
Customer Accessible Production Drawing		REV: M1			

LOC	DIST	REV	DESCRIPTION	DATE	OWN	APVD
A	66		SEE SHEET 1			

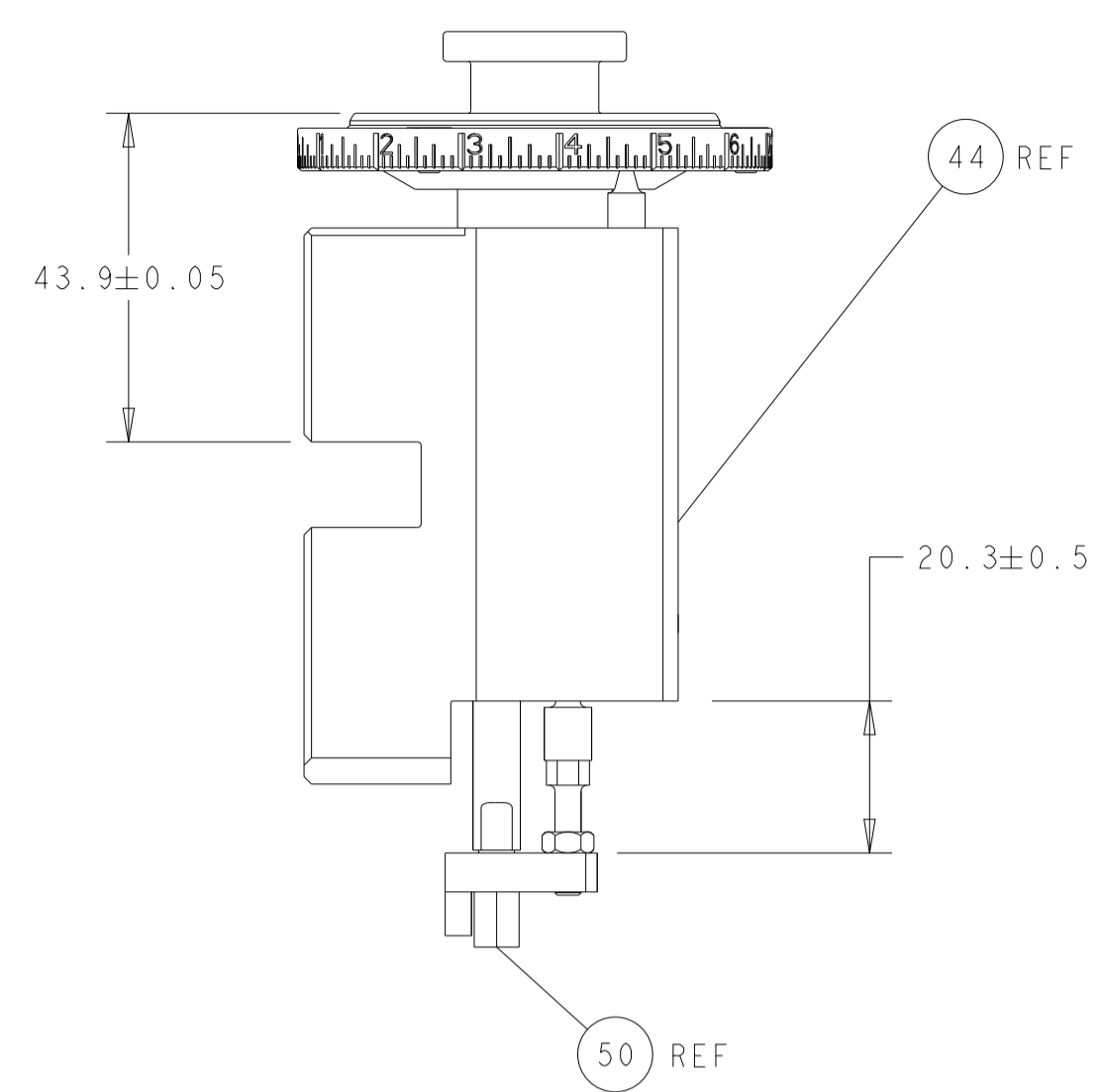

RAM AND HOLDDOWN SET-UP

FEED TYPE
MECHANICAL

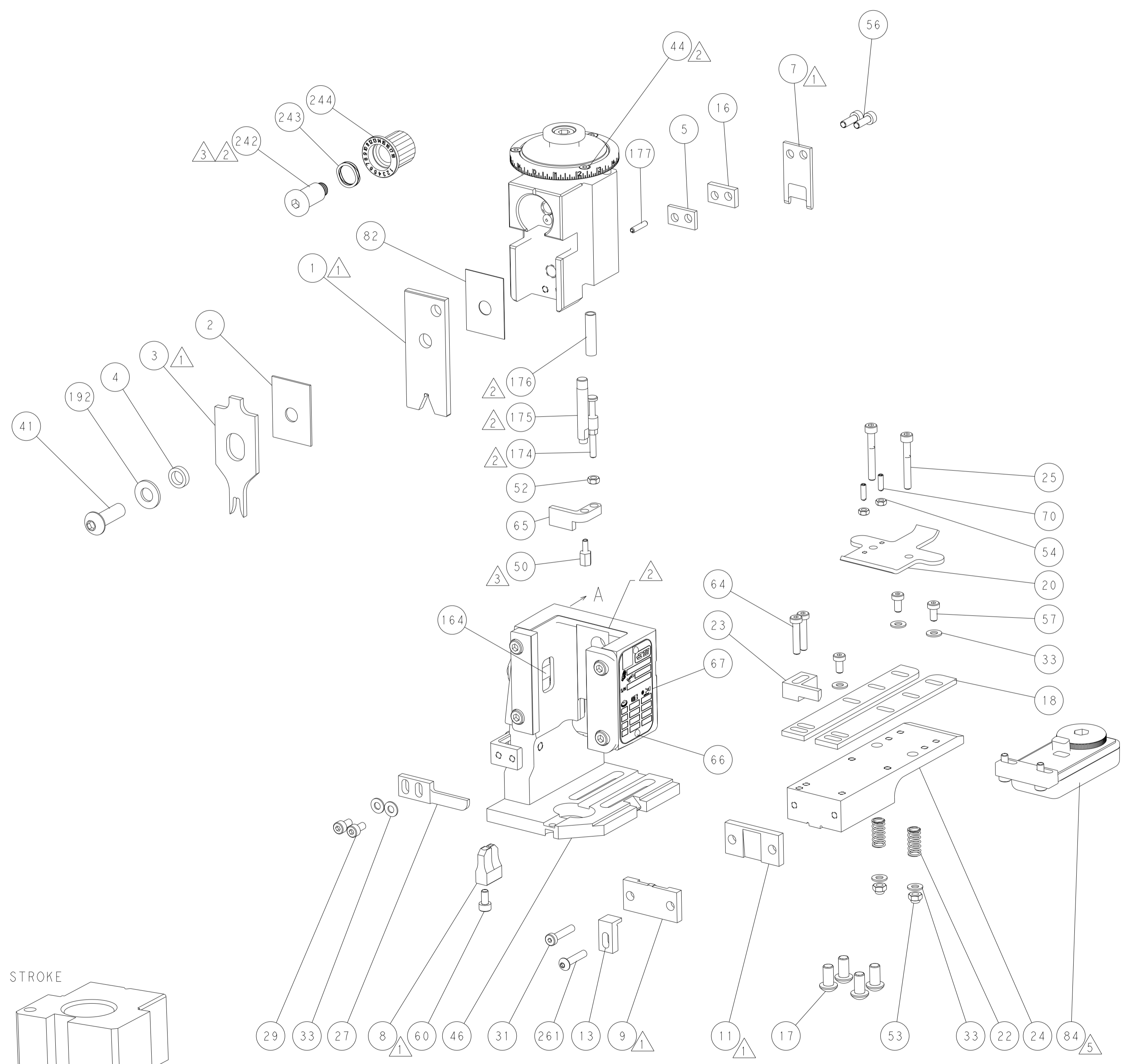
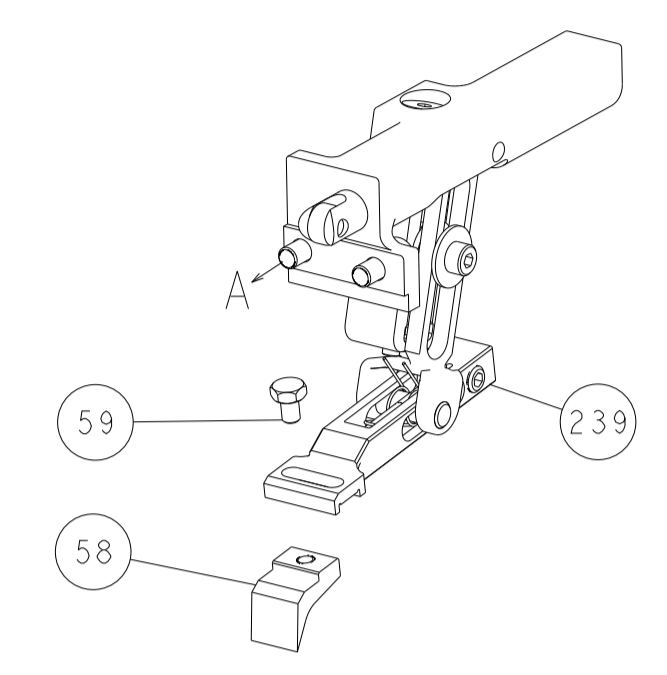

PNEUMATIC

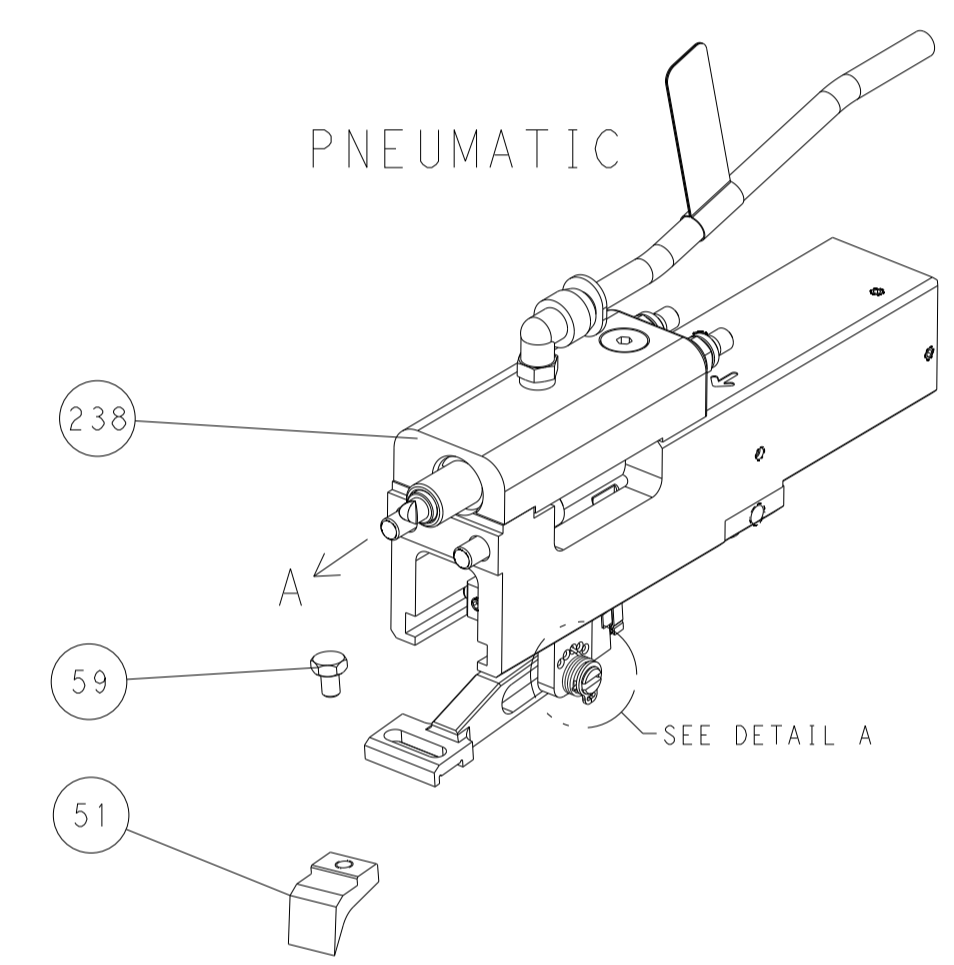

FEED SPRING
SETTING POSITION

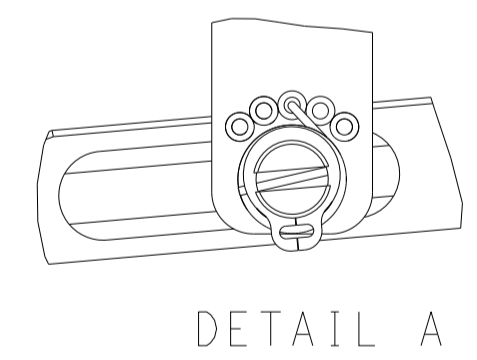

CAM POSITIONS

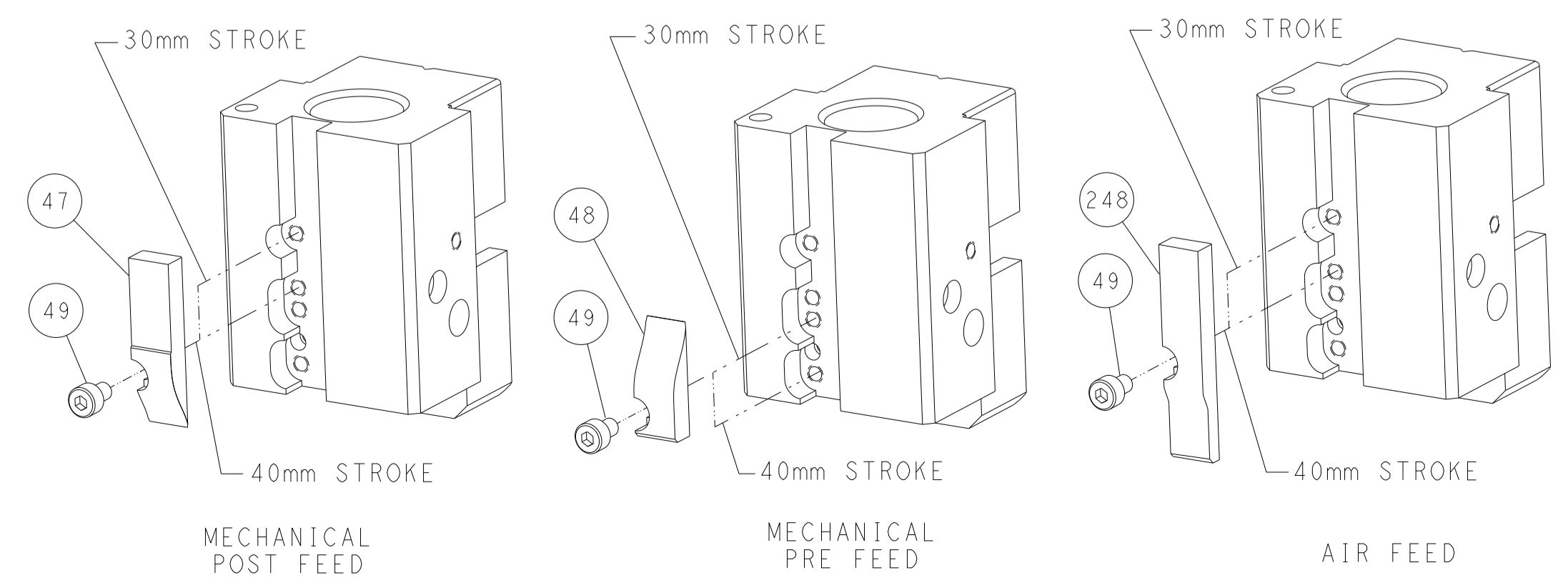

ATLANTIC VERSION
 Shown on sheets 1 of 4 & 2 of 4
 (Pacific version shown on sheets 3 of 4 & 4 of 4)

DIMENSIONS: mm 		TOLERANCES UNLESS OTHERWISE SPECIFIED: 0 PLC ± 1 PLC ± 2 PLC ± 3 PLC ± 4 PLC ± ANGLES ± FINISH		DWN B. WEAVER 29NOV2011 CHK G. HOFFNER 29NOV2011 APVD T. ELBLIN 29NOV2011		NAME Ocean End Feed Applicator	
MATERIAL:		WEIGHT:		SIZE CAGE CODE DRAWING NO A1 00779 C=2150016		RESTRICTED TO	
Customer Accessible Production Drawing				SCALE 1:1		SHEET 2 OF 4 REV M1	

PART NUMBER	REVISION	DESCRIPTION	FEED TYPE
2-2150016-1	L	FINE CRIMP HEIGHT ADJUST	MECHANICAL
2-2150016-2	M	FINE CRIMP HEIGHT ADJUST	PNEUMATIC
7-2150016-7	H	CRIMP TOOLING KIT	-

PACIFIC VERSION TERMINATOR
INTERFACE ADAPTER

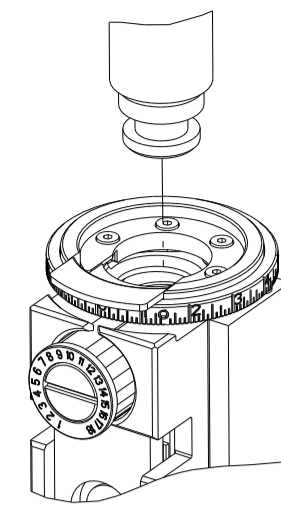

APPLICATOR DATA		
CRIMP	SIZE	TYPE
WIRE	2.79 mm [.110]	F
INSUL	4.57 mm [.180]	F
APPLICATOR INSTRUCTIONS 408-35043		

TERMINAL DATA: TE TERMINAL		TE CRIMP SPECIFICATION	
TERMINAL NAME: RECEPTACLE, FASTON .250 SERIES			
WIRE STRIP LENGTH 6.00-6.80 mm [.236-.268 IN]		INSULATION DIAMETER RANGE Ø3.05-4.31 mm [.120-.170 IN]	
TERMINAL APPLICATION SPECIFICATION	114-2036	-	-
TERMINALS APPLIED 5			
TE TERMINAL	TE TERMINAL	TE TERMINAL	TE TERMINAL
63306-1	60713-1	42660-1	1217393-1
63306-2	60713-2	42660-2	63985-1
42400-1	350981-2	60650-1	63674-1
42400-2	42219-1	60650-2	1742948-1
42400-3	42219-2	60650-3	1742971-4
1742198-1	154692-1	1217272-1	2238196-3
1742198-2	1742198-4	1742198-5	1742198-6
2-1742198-4	2-1742198-6		

WIRE SIZE	CRIMP HEIGHT mm [INCH]	CRIMP HEIGHT REFERENCE SETTING
14 AWG	1.85+/-0.05 [.073+/-0.002]	7.5
(1)18 & (1)16	1.85+/-0.05 [.073+/-0.002]	7.5
(2)18	1.73+/-0.05 [.068+/-0.002]	9.0
16 OR (1)20 & (1)18	1.63+/-0.05 [.064+/-0.002]	10.0
18 AWG	1.47+/-0.05 [.058+/-0.002]	11.7

***WARNING**
ON INSTALLATION, SET WIRE DISC TO CRIMP HEIGHT REFERENCE SETTING FOR LARGEST WIRE SIZE. CRIMP HEIGHT REFERENCE SETTINGS GREATER THAN THE VALUE SHOWN MAY CAUSE DAMAGE TO THE CRIMP TOOLING. REFER TO THE INSTRUCTION SHEET FOR PROPER SETUP AND ADJUSTMENTS.



- 1 RECOMMENDED SPARE PARTS
- 2 REFER TO SUPPLIED INSTRUCTION SHEET FOR CLEANING, LUBRICATION AND STORAGE OF APPLICATOR.
- 3 APPLY PART NUMBER 2-23419-6 LOCTITE TO THREADS OF ITEM 242. APPLY PART NUMBER 1-23419-5 LOCTITE TO THREADS OF ITEM 50.
- 4 CRIMP HEIGHT REFERENCE SETTING WAS THE SETTING USED WHEN THE APPLICATOR WAS QUALIFIED AT THE FACTORY. ADJUSTMENT MAY BE NECESSARY WHEN RUNNING APPLICATOR IN THE FIELD.
- 5 TERMINAL LUBRICANT IS RECOMMENDED.
- 6. UNLESS SPECIFIED OTHERWISE TORQUE VALUES SHALL BE USED PER DOCUMENT, 101-35000.

LOC	DIST	REVISIONS					
A	66	P	LTN	DESCRIPTION	DATE	OWN	APVD
-	-	-	-	SEE SHEET 1	-	-	-

-	1	1	2079383-5	SCR, BHSC, RoHS (M4 X 20)	261
-	1	1	2119082-9	CAM, SNAIL, INSULATION ADJUSTMENT	244
-	1	1	2079764-1	WASHER, WAVE SPRING, CREST-TO-CREST	243
-	1	1	2119083-1	RETAINER, INSULATION DIAL	242
-	-	1	2119580-1	MECHANICAL FEED ASSEMBLY	239
-	1	-	2844940-3	AIR FEED MODULE	238
-	1	1	1-18028-0	WASHER, FLAT, REG M8	192
-	4	4	2079383-9	SCR, BHSC, RoHS (M6 X 20)	186
-	1	1	6-993111-6	PIN, SLOTTED SPRING 3.0 X 14.0	177
-	1	1	8-22280-7	SPRING, COMPRESSION	176
-	1	1	1752353-2	GUIDE PIN,HOLDDOWN	175
-	1	1	1901680-2	GUIDE PIN,HOLDDOWN	174
-	REF	REF	994970-2	COUNTER, MAGNETIC	164
-	1	-	2119641-2	FEED CAM, AIR FEED	152
-	1	1	2168083-8	SCR, SKT HD CAP, RoHS, M4 X 16	144
-	-	1	2119653-2	FEED CAM, POST FEED	142
-	1	1	2119655-6	APPLICATOR BASIC ASSEMBLY, EF	141
-	1	1	1803518-1	RAM ASSEMBLY, EF PACIFIC	140
-	1	1	2119955-2	ASSY, LUBRICATOR, END FEED	84
-	1	1	455888-4	SPACER, CRIMPER	82
-	1	1	1803607-4	DOCUMENTATION PACKAGE	71
-	2	2	2-18032-2	SCR, SET, FLT PNT, M3 X 10.0	70
-	1	1	2119740-1	TAG, IDENTIFICATION	67
-	2	2	2168078-1	SCREW, DRIVE, RH, RoHS, 2 x .188	66
-	1	1	1901681-5	HOLDDOWN, TERMINAL	65
-	2	2	2168400-5	SHCS, LOW HEAD, RoHS, M4 X 20	64
-	1	1	5-18022-5	SCR, HEX HD CAP, M4 X 6.0	59
-	-	1	2063961-1	FEED FINGER	58
-	3	3	2168400-4	SHCS, LOW HEAD, RoHS, M4 X 8	57
-	2	2	2168083-3	SCR, SKT HD CAP, RoHS, M4 X 12.0	56
-	2	2	5018030-1	NUT, HEX, REG, RoHS, M3	54
-	2	2	986965-8	NUT, LOCK, HEX, TORQUE (M4)	53
-	1	1	1-5018030-0	NUT, HEX, REG, RoHS, M3.5	52
-	1	-	2063961-1	FEED FINGER	51
-	1	1	1-1752354-4	STANDOFF,HOLD-DOWN	50
-	1	2	18023-9	SCR, SKT HD CAP M4 X 6.0	49
-	-	1	2119652-1	FEED CAM, PRE FEED	48
-	1	1	1803602-1	SCR, BHSC, RoHS (M8 X 25)	41
-	7	7	1-18028-2	WASHER, FLAT, REG M4	33
-	1	1	2168400-5	SHCS, LOW HEAD, RoHS, M4 X 20	31
-	2	2	2168083-2	SCR, SKT HD CAP, RoHS, M4 X 8.0	29
-	1	1	240639-1	STRIPPER (MACHINING)	27
-	2	2	1-2168083-5	SCR, SKT HD CAP, RoHS, M4 X 30	25
-	1	1	1752371-1	PLATE, STRIP GUIDE	24
-	1	1	240825-1	PLATE, STRIP HOLD DOWN	23
-	2	2	2-22281-3	SPRING, COMPRESSION	22
-	1	1	1803292-4	DRAG	20
-	2	2	1901259-6	GUIDE, LOWER STRIP	18
-	1	1	240641-1	SPACER	16
-	1	1	1752360-1	SPACER,HOLD-DOWN	13
-	1	1	240644-1	PLATE, REAR SHEAR	11
-	-	-	-	-	10
-	1	1	690495-4	PLATE, FRONT SHEAR	9
-	1	1	3-1803000-1	ANVIL, COMBINATION, END FEED	8
-	1	1	1-2217206-4	BLADE, SLUG	7
-	1	1	1-240641-6	SPACER	5
-	1	1	238011-2	BLOCK, CRIMPER SPACER	4
-	1	1	2119582-3	CRIMPER, INSULATION F PREMIUM	3
-	1	1	1-455888-0	SPACER, CRIMPER	2
-	1	1	1-1633730-9	CRIMPER, WIRE	1

PACIFIC VERSION
Shown on sheets 3 of 4 & 4 of 4
(Atlantic version shown on sheets 1 of 4 & 2 of 4)

DIMENSIONS:		TOLERANCES UNLESS OTHERWISE SPECIFIED:		MATERIAL:	
mm	0 PLC ±	1 PLC ±	2 PLC ±	3 PLC ±	4 PLC ±
	ANGLES	FINISH			

CHK	B. WEAVER	29NOV2011	NAME	TE Connectivity
CHK	G. HOFFNER	29NOV2011	NAME	Harrisburg, PA 17105-3608
APVD	T. ELBIN	29NOV2011	NAME	Ocean End Feed Applicator
PRODUCT SPEC			SIZE	CAGE CODE
APPLICATION SPEC			00779	2150016
WEIGHT			SCALE	1:1
			SHEET	3 OF 4
			REV	M1

LOC	DIST	REVISIONS					
A	66	P	LTN	DESCRIPTION	DATE	OWN	APVD
		-		SEE SHEET 1	-	-	-

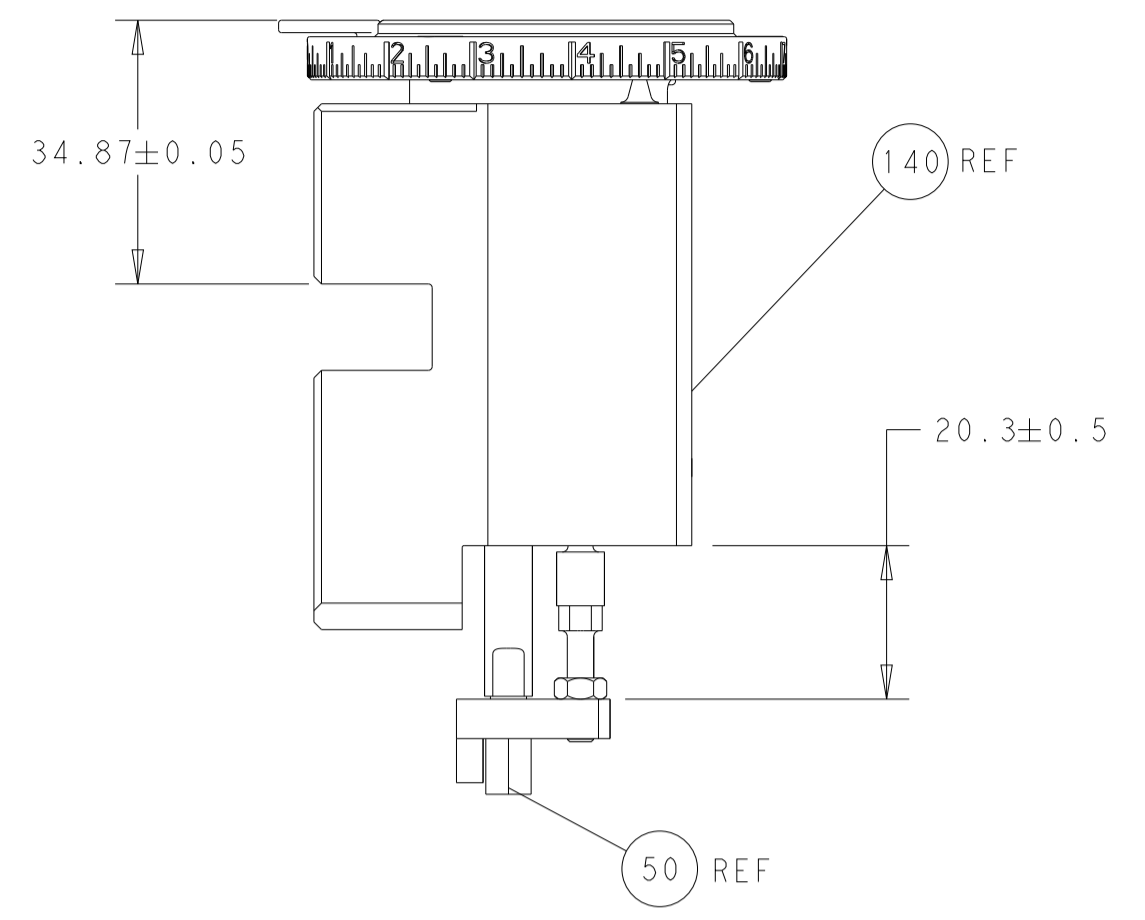

RAM AND HOLDDOWN SET-UP

FEED TYPE
MECHANICAL

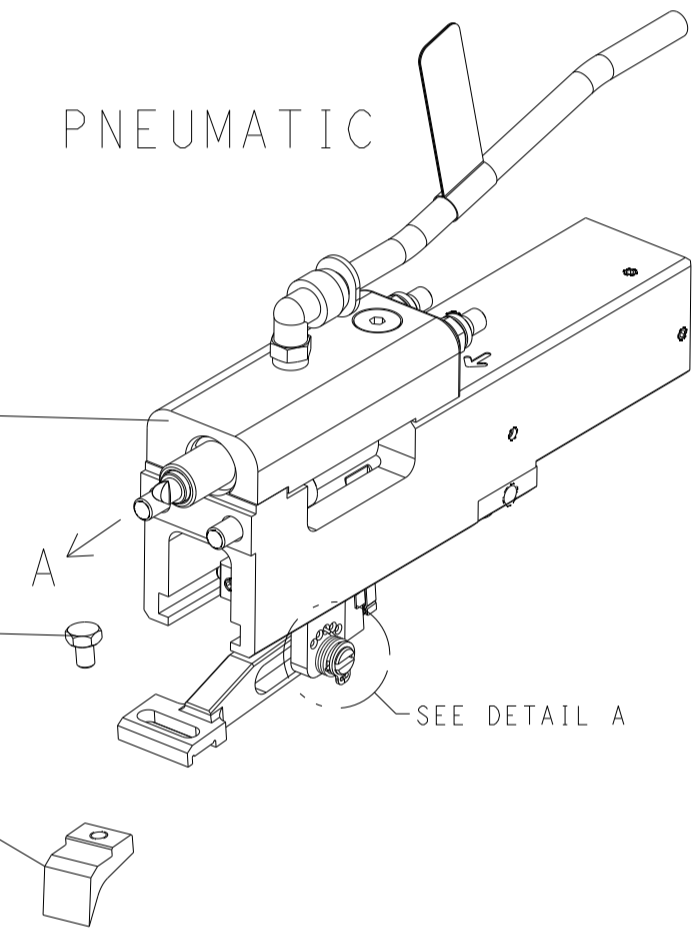
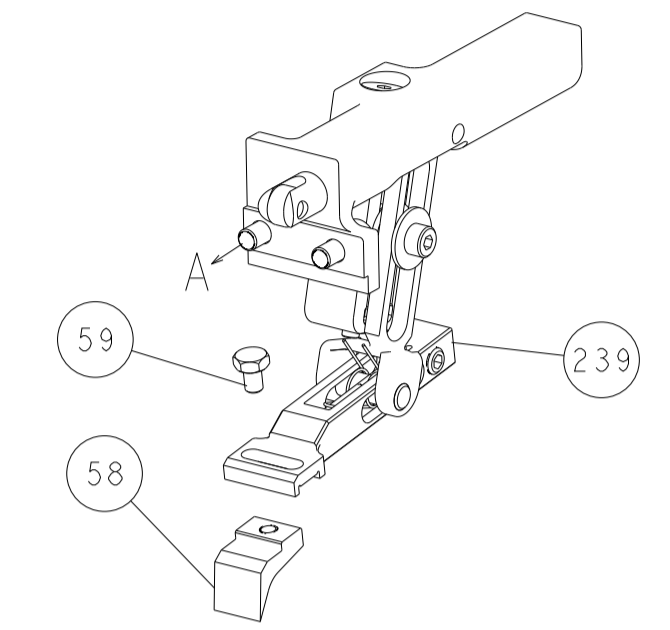

FEED SPRING
SETTING POSITION

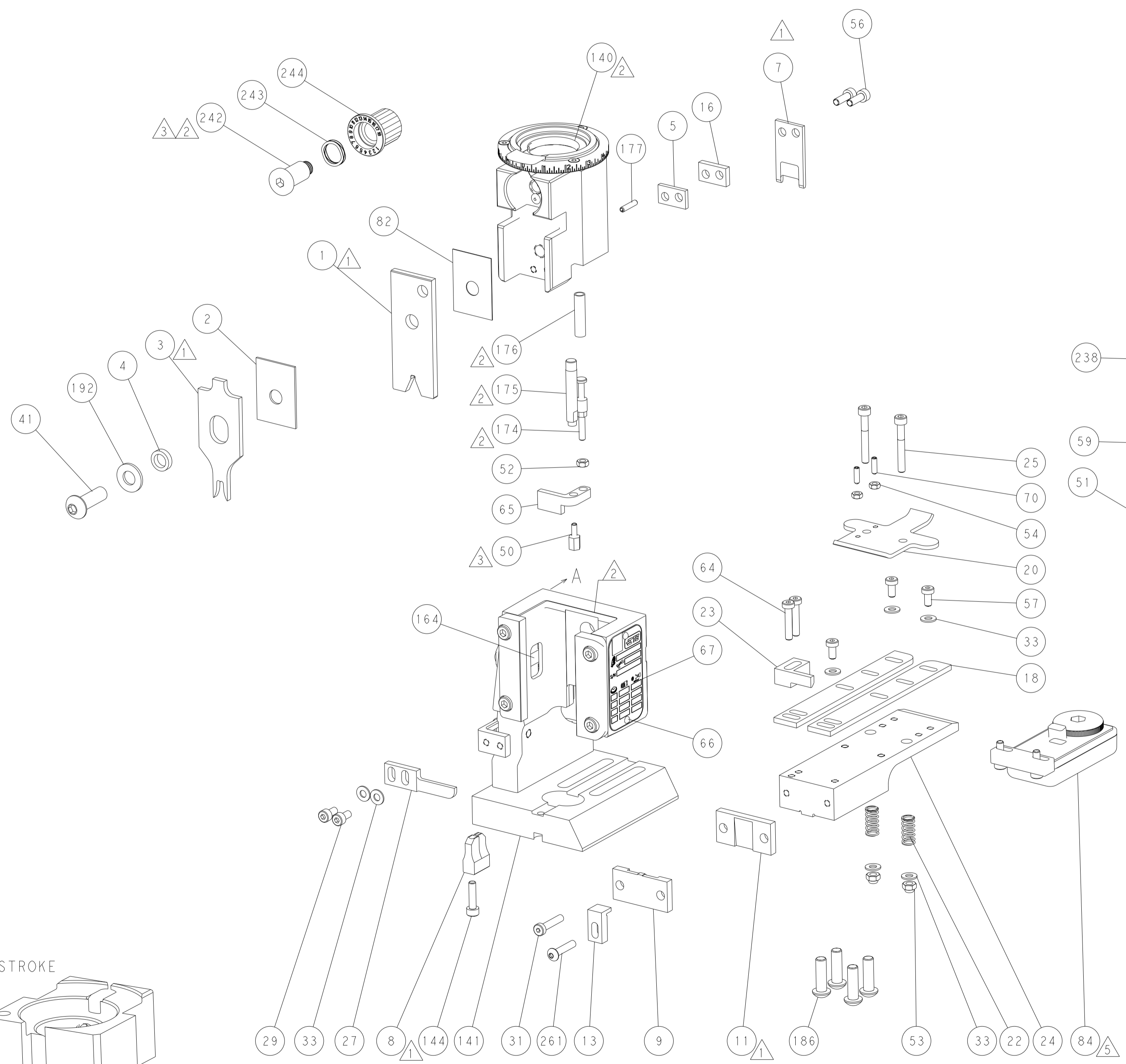
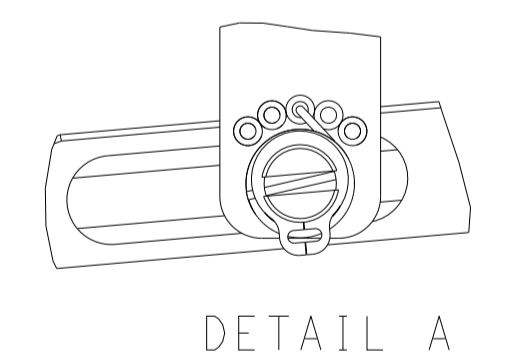

CAM POSITIONS

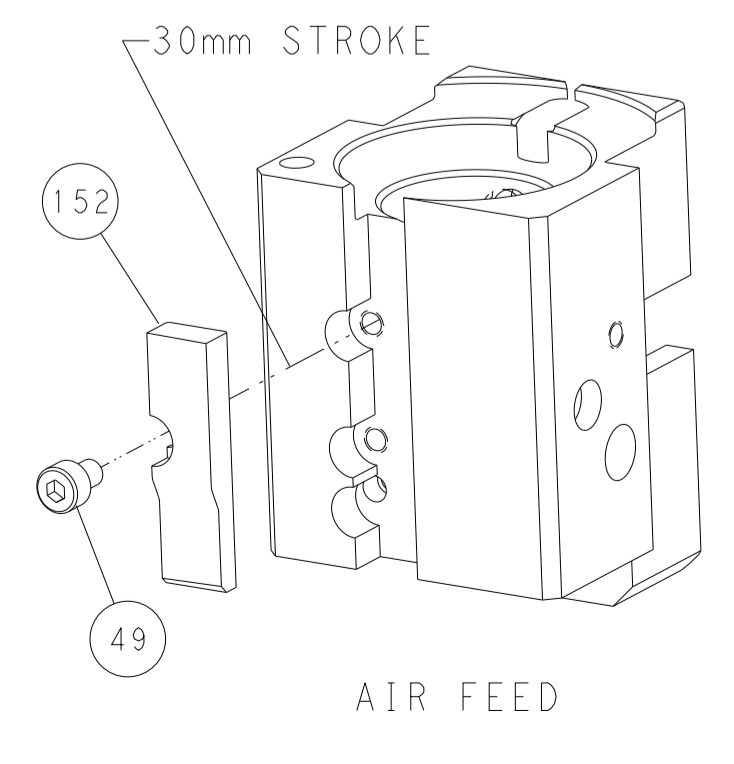
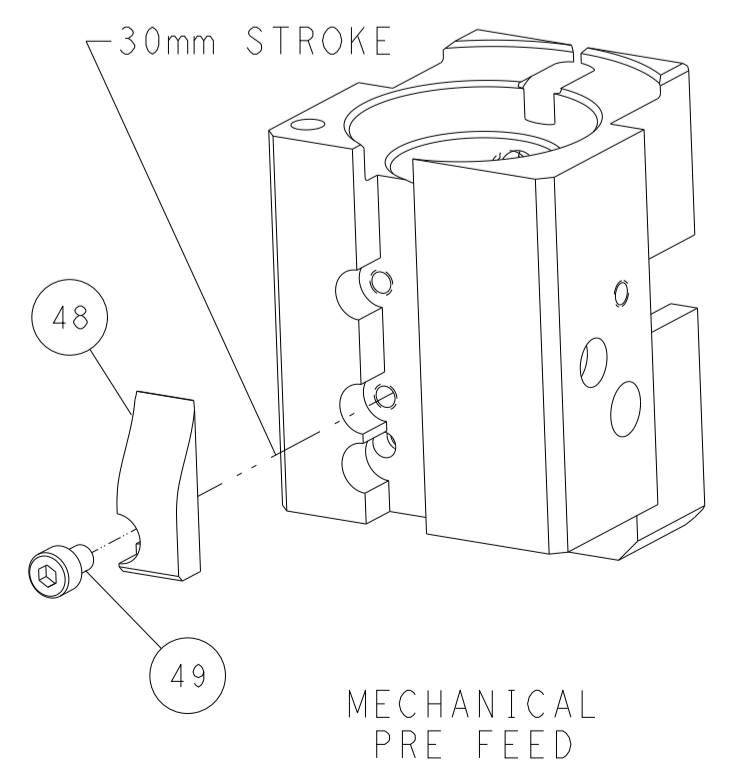
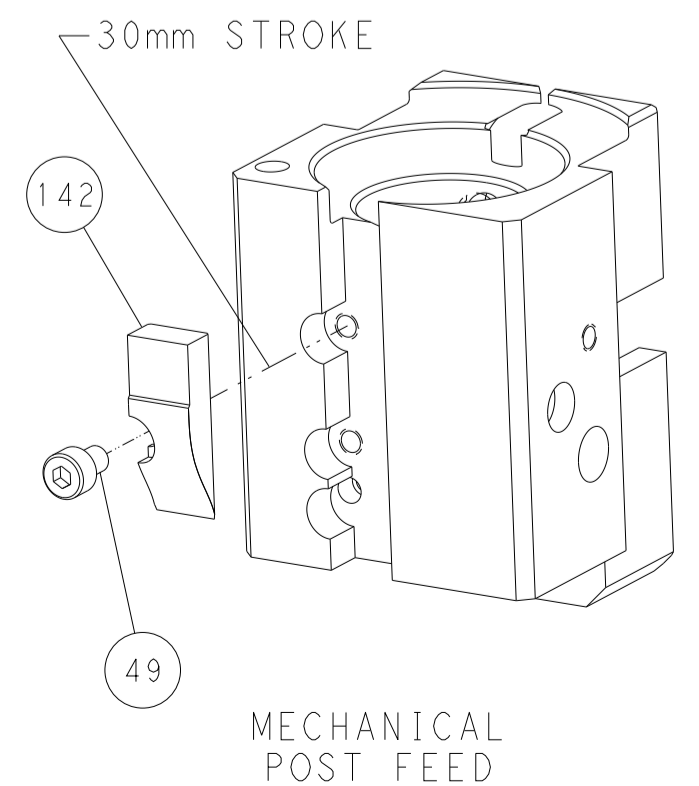

PACIFIC VERSION
 Shown on sheets 3 of 4 & 4 of 4
 (Atlantic version shown on sheets 1 of 4 & 2 of 4)

<small>THIS DRAWING IS UNPUBLISHED. RELEASED FOR PUBLICATION 2011 BY TYCO ELECTRONICS CORPORATION. ALL RIGHTS RESERVED.</small>		DWN B. WEAVER 29NOV2011 CHK G. HOFFNER 29NOV2011 APVD T. ELBIN 29NOV2011	NAME Ocean End Feed Applicator
DIMENSIONS: mm 0 PLC ± 1 PLC ± 2 PLC ± 3 PLC ± 4 PLC ± ANGLES ± MATERIAL - FINISH -	TOLERANCES UNLESS OTHERWISE SPECIFIED: 0 PLC ± 1 PLC ± 2 PLC ± 3 PLC ± 4 PLC ± ANGLES ± MATERIAL - FINISH -	SIZE CAGE CODE DRAWING NO A1 00779 C=2150016	RESTRICTED TO Customer Accessible Production Drawing SCALE 1:1 SHEET 4 OF 4 REV M1