

LOC	DIST	REVISIONS					
		P	LTN	DESCRIPTION	DATE	DMN	APVD
FX	00	J		REVISED PER EC 0K40-0680-03	22DEC2003	DLD	SLM
		K		REVISED PER ECO-10-004862	09MAR2010	DLD	LLV
		KI		REVISED PER ECO-20-014443	13OCT2020	RM	-

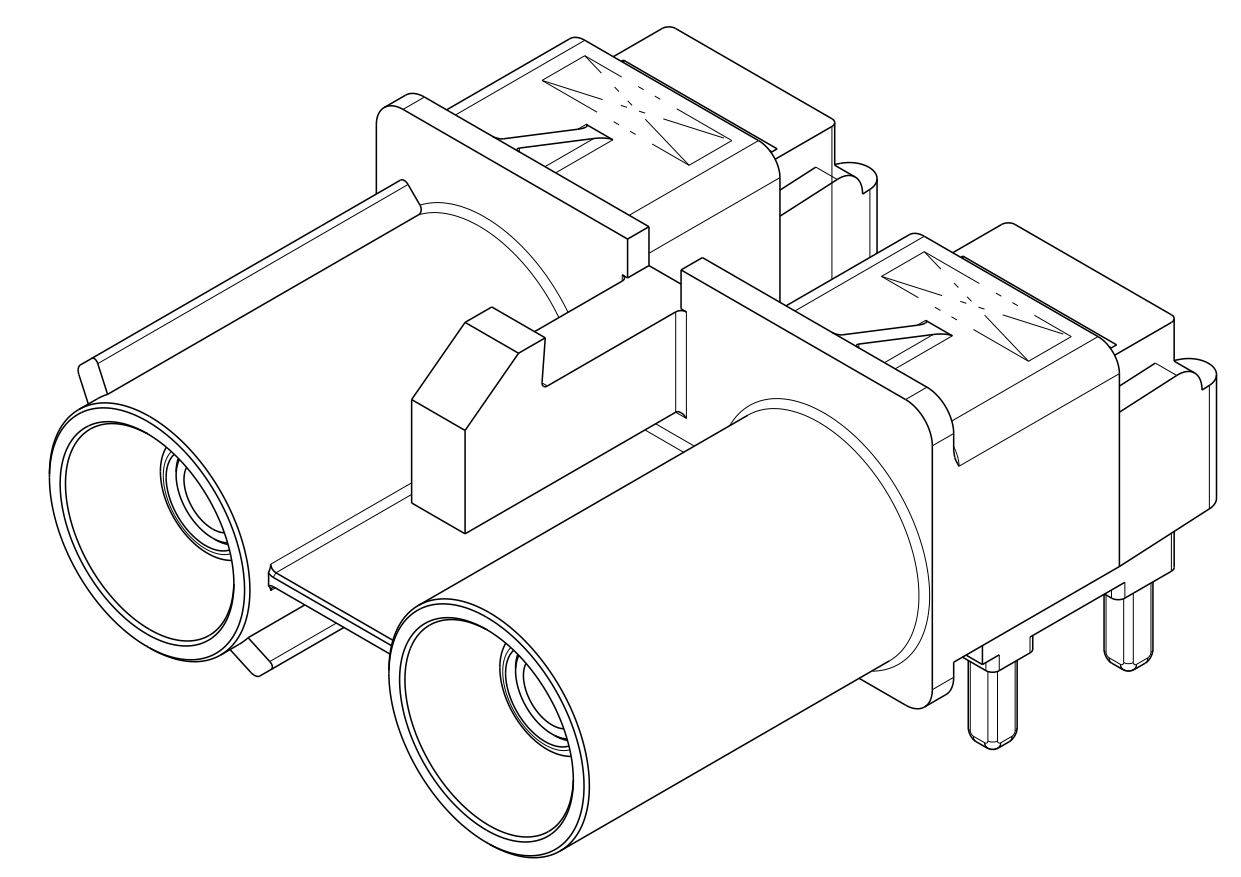

- 1 MATERIAL:
HOUSING: PBT
JACK: ZINC
PIN: BRASS
DIELECTRIC - REAR: POLYMETHYLPENTENE AND FRONT: TEFLON
- 2 DIMENSION ESTABLISHED BY CUSTOMER RELATIVE TO LOCATION ON PCB.
- 3 JACK INTERFACE PER SAE-USCAR-18, FAKRA SMB RF CONNECTOR SUPPLEMENT.
- 4 FINISH:
JACK: PLATE 2.0µm - 4.0µm TIN OVER 1.52µm - 4.06µm BRIGHT NICKEL OVER 2.54µm COPPER FLASH
PIN: 1.27µm MINIMUM THICK GOLD OVER 1.3µm MINIMUM THICK NICKEL

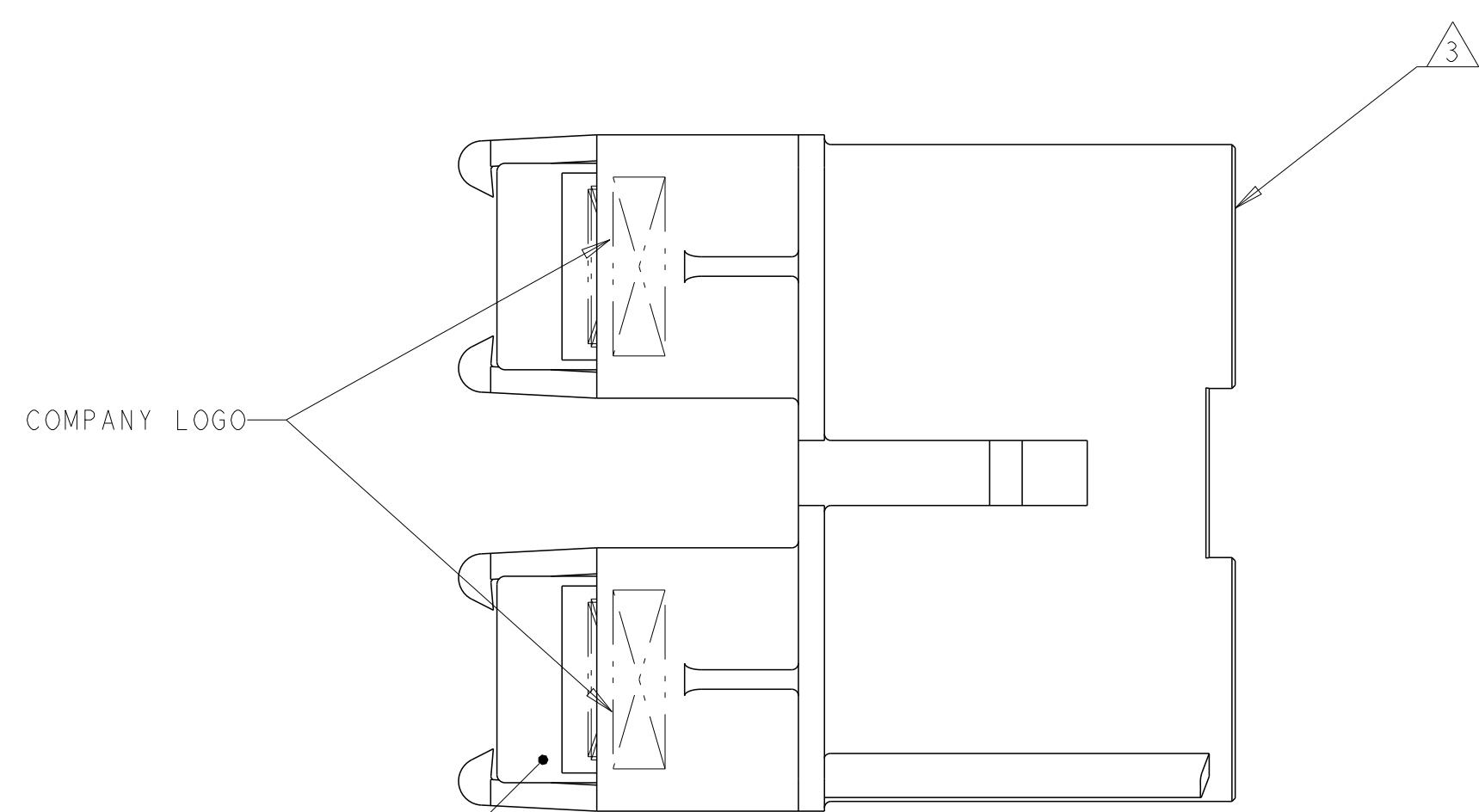
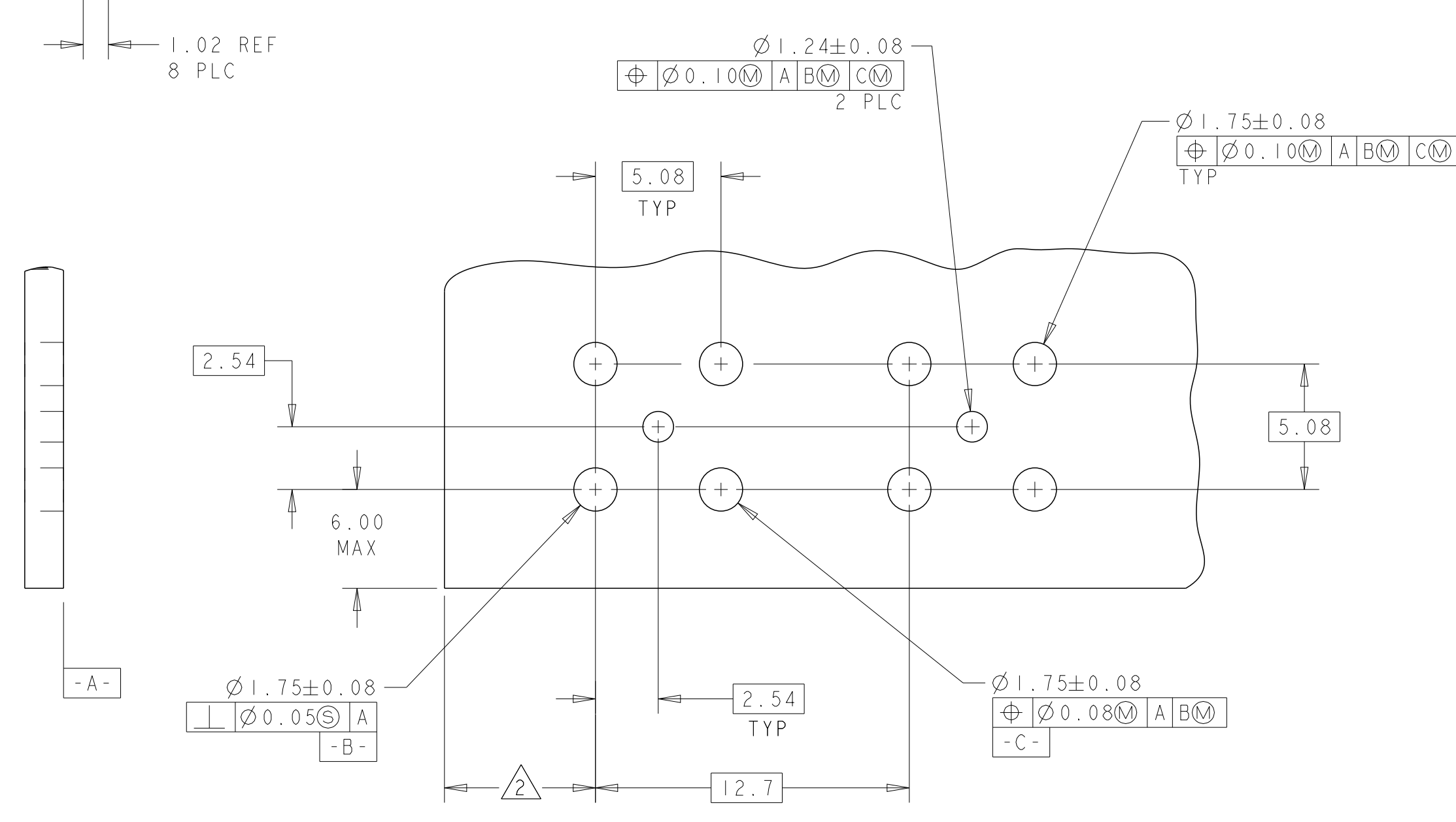
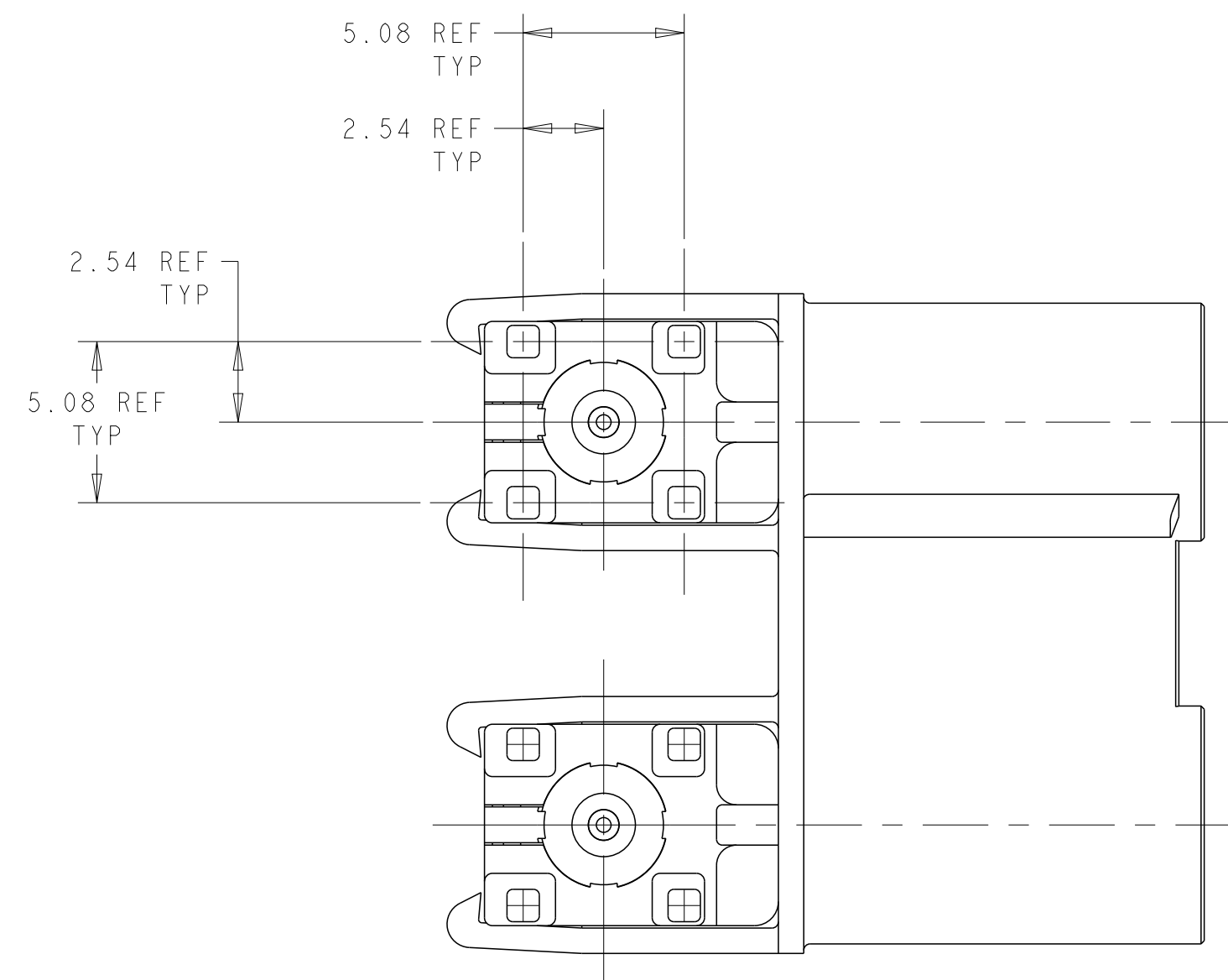
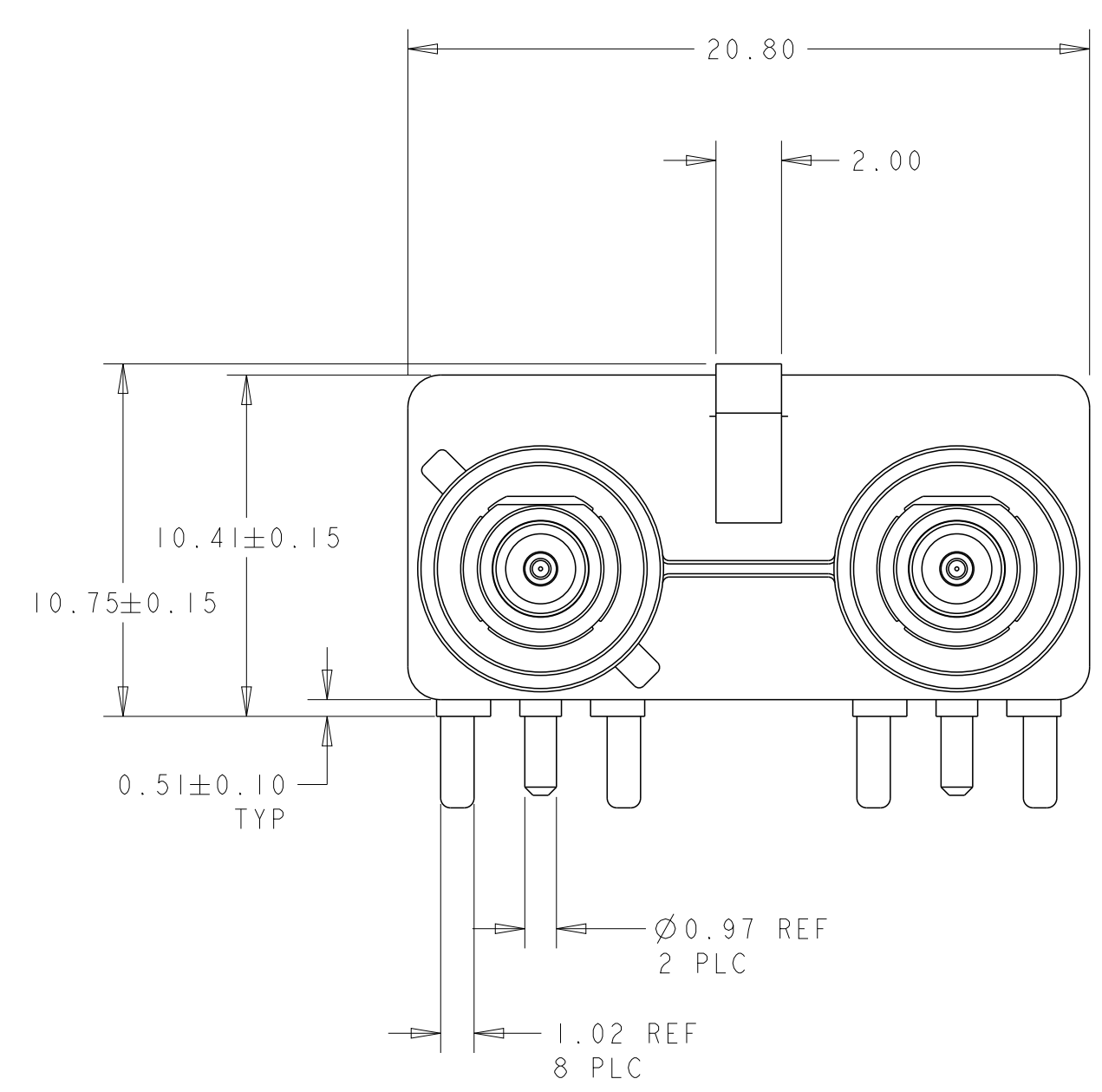
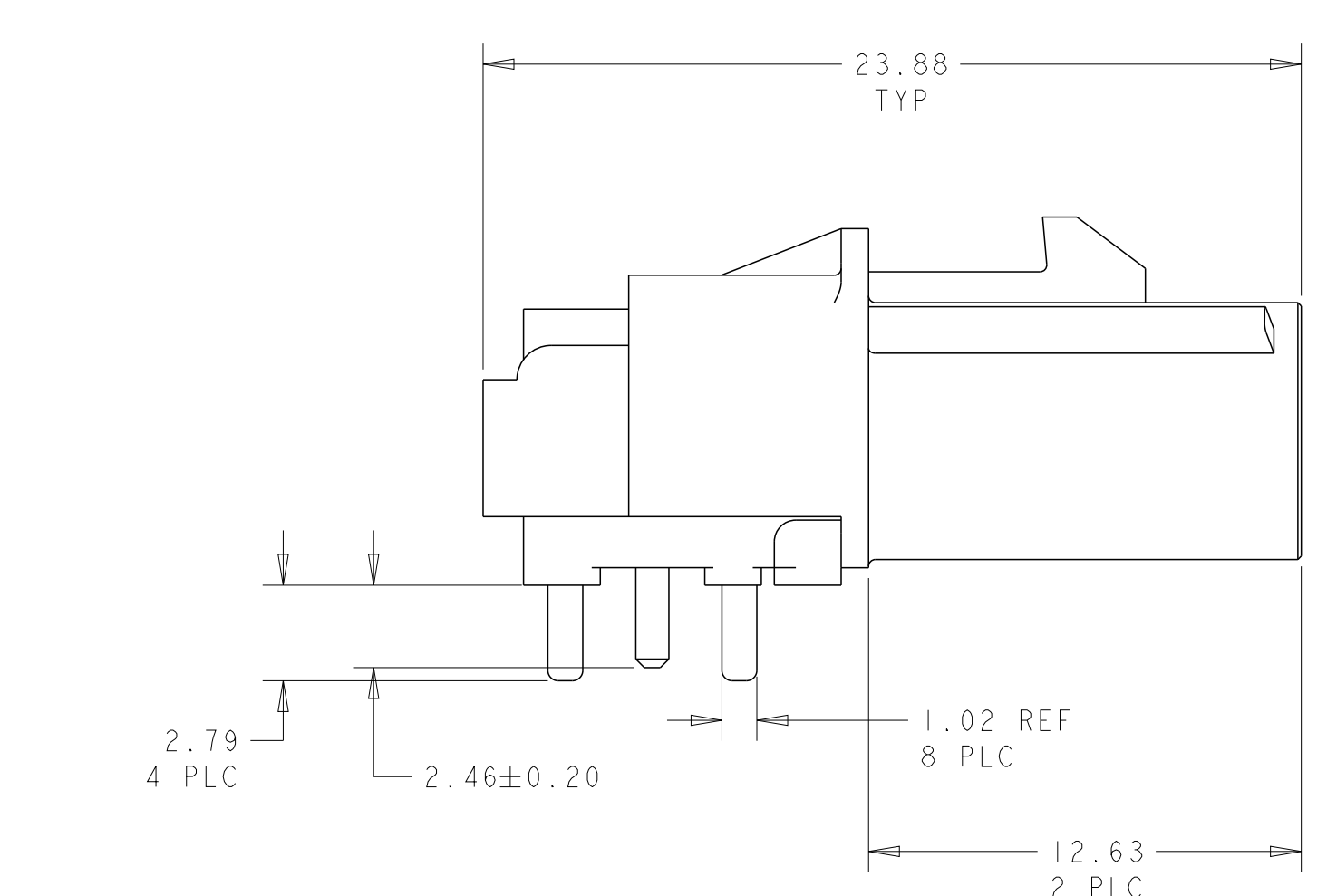

RECOMMENDED PC BOARD LAYOUT

KI **OBsolete**

KI **OBsolete**

PER DETAIL Z	Z	WATER BLUE	1-638818-1
PER DETAIL W	G2	BLUE GREY	638818-7
PER DETAIL V	F2	BROWN	638818-6
PER DETAIL U	E2	LEAF GREEN	638818-5
PER DETAIL T	D2	BORDEAUX VIOLET	638818-4
PER DETAIL S	C2	SIGNAL BLUE	638818-3
PER DETAIL R	B2	SIGNAL WHITE	638818-2
PER DETAIL L	A2	DEEP BLACK	638818-1
KEYING	KEY IDENTIFIER	JACK HOUSING COLOR	PART NUMBER

DIMENSIONS: mm 		TOLERANCES UNLESS OTHERWISE SPECIFIED: 0 PLC ± 1 PLC ±0.25 2 PLC ± 3 PLC ± 4 PLC ± ANGLES ± FINISH ±		DWN D. HARDY 05JUL00 CHK J.W. HALL 06JUL00 APVD J.W. HALL 06JUL00	Tyco Electronics Harrisburg, PA 17105-3608
MATERIAL 1 FINISH 4		WEIGHT 8.22g CUSTOMER DRAWING	NAME JACK ASSEMBLY, FAKRA, 2 POSITION, RIGHT ANGLE, PCB, 50 Ohm, SMB PRODUCT SPEC 108-2054 APPLICATION SPEC 114-13043 SIZE 114-13043 CAGE CODE 00779 DRAWING NO C=638818	RESTRICTED TO SCALE 5:1 SHEET 1 OF 2 REV KI	

THIS DRAWING IS UNPUBLISHED. RELEASED FOR PUBLICATION 20
 COPYRIGHT 20 BY TYCO ELECTRONICS CORPORATION. ALL RIGHTS RESERVED.

LOC		DIST		REVISIONS				
P	LYN	DATE	DMN	APVD	DESCRIPTION	DATE	DMN	APVD
-	-	SEE SHEET 1	-	-	-	-	-	-

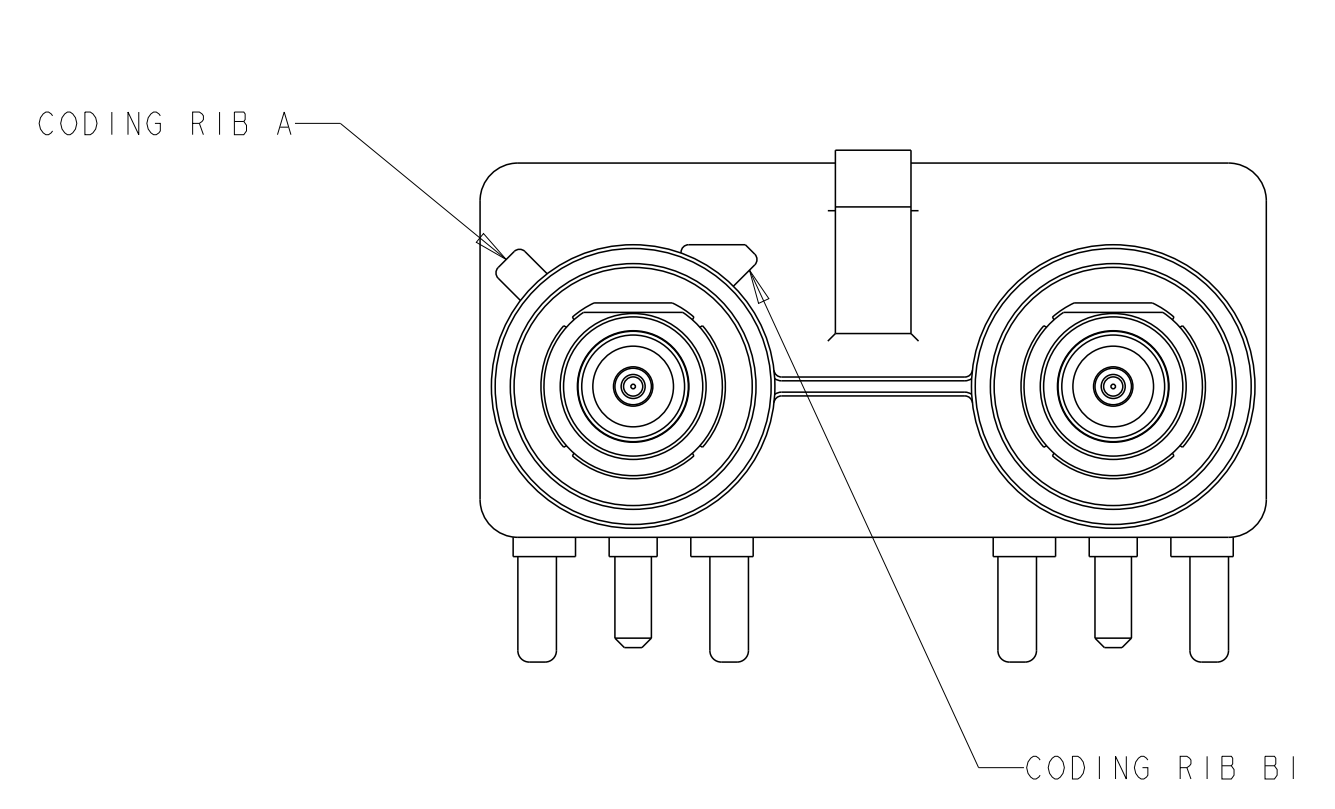

DETAIL L

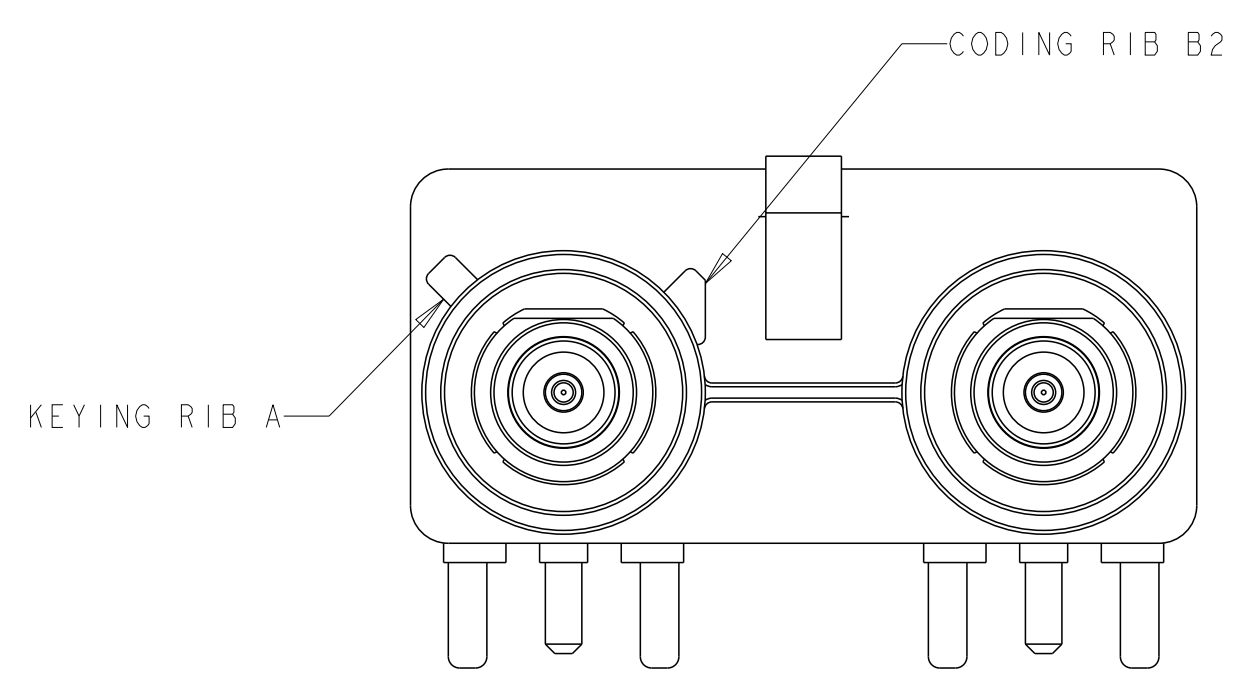

DETAIL R

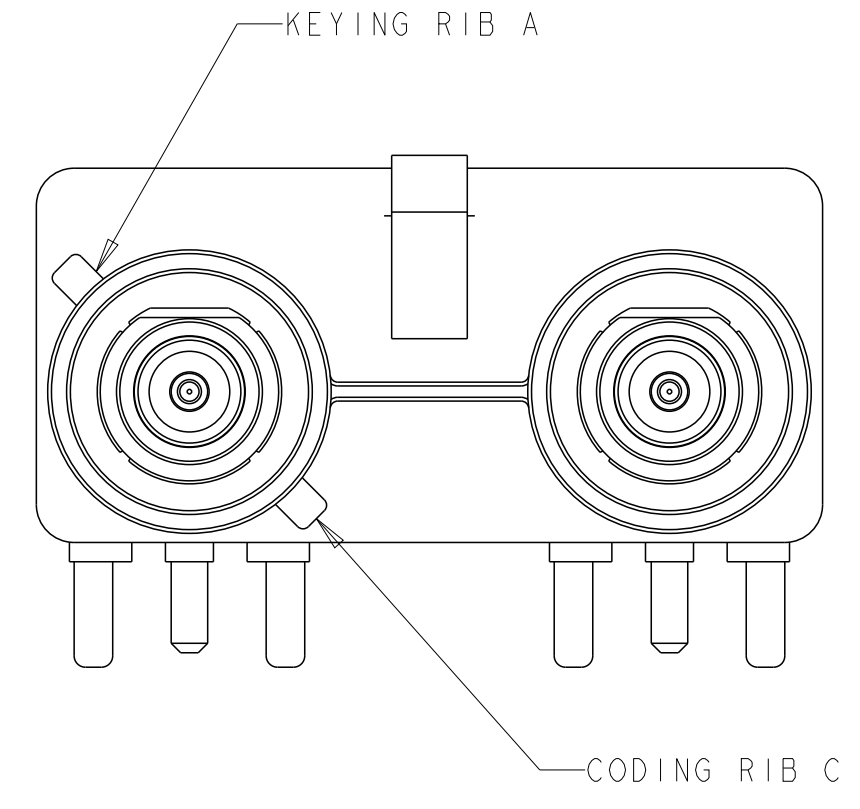

DETAIL S

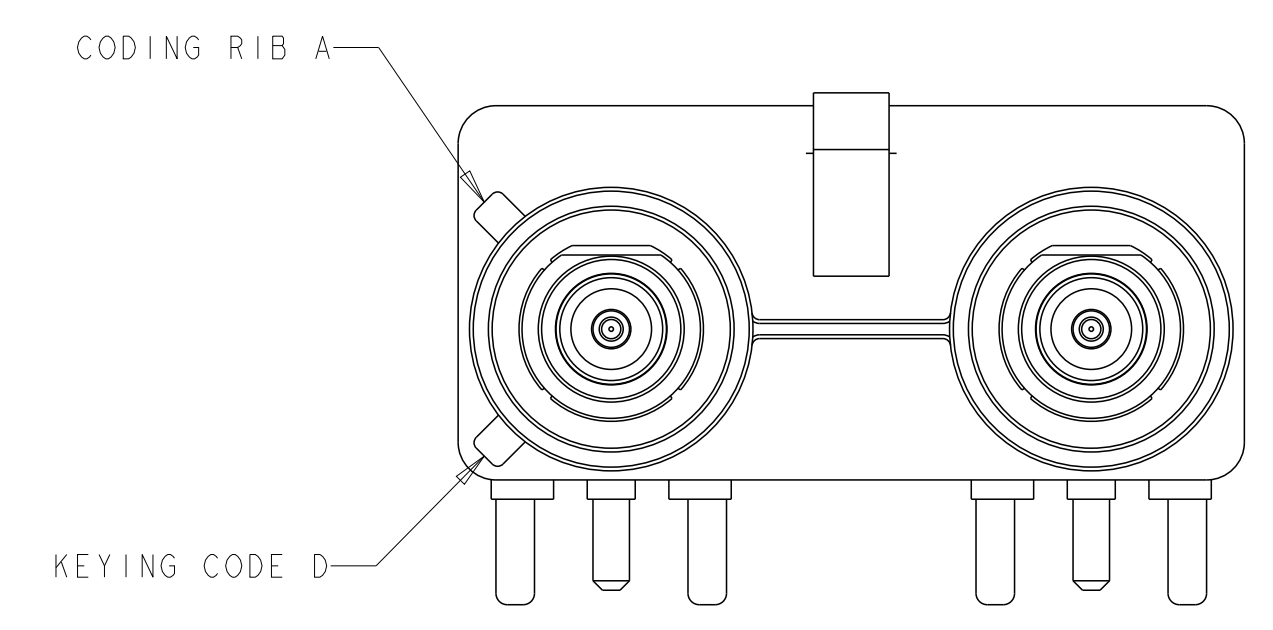

DETAIL T

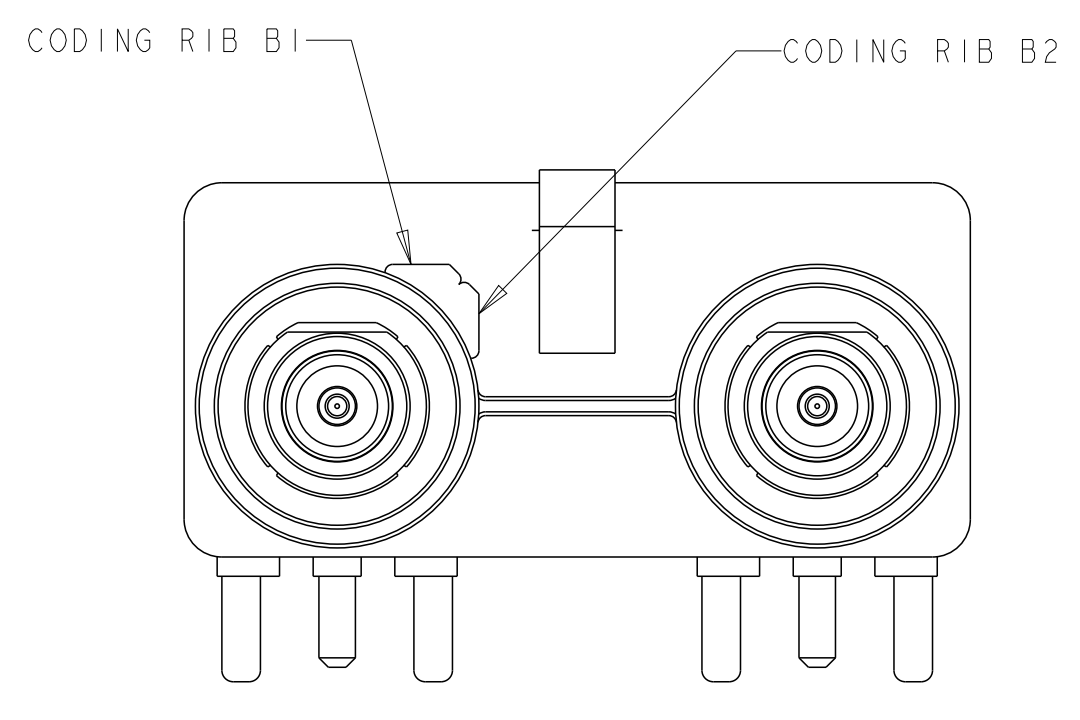

DETAIL U

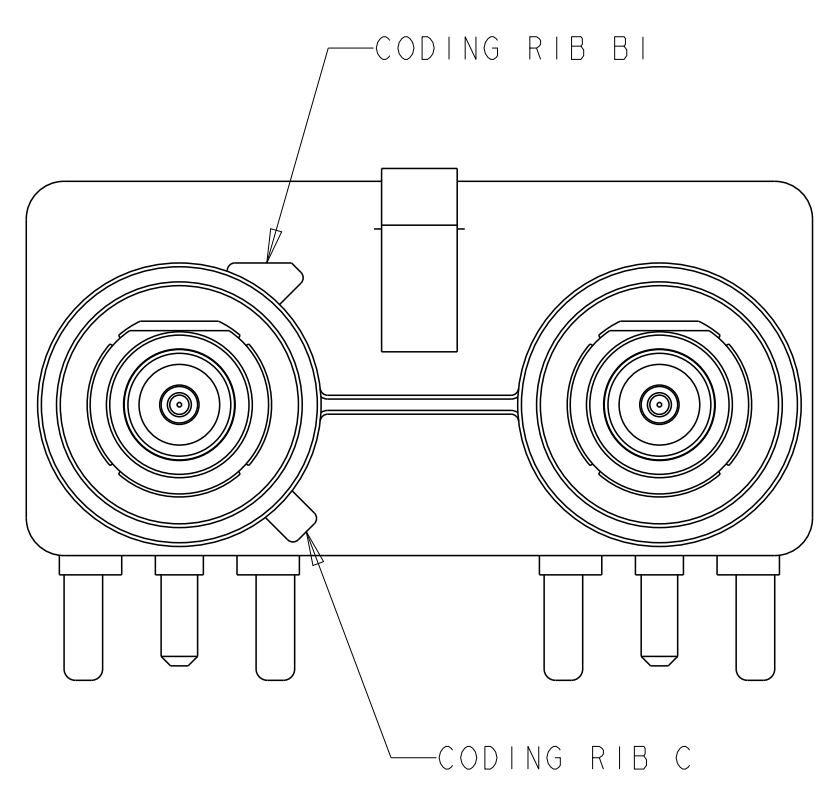

DETAIL V

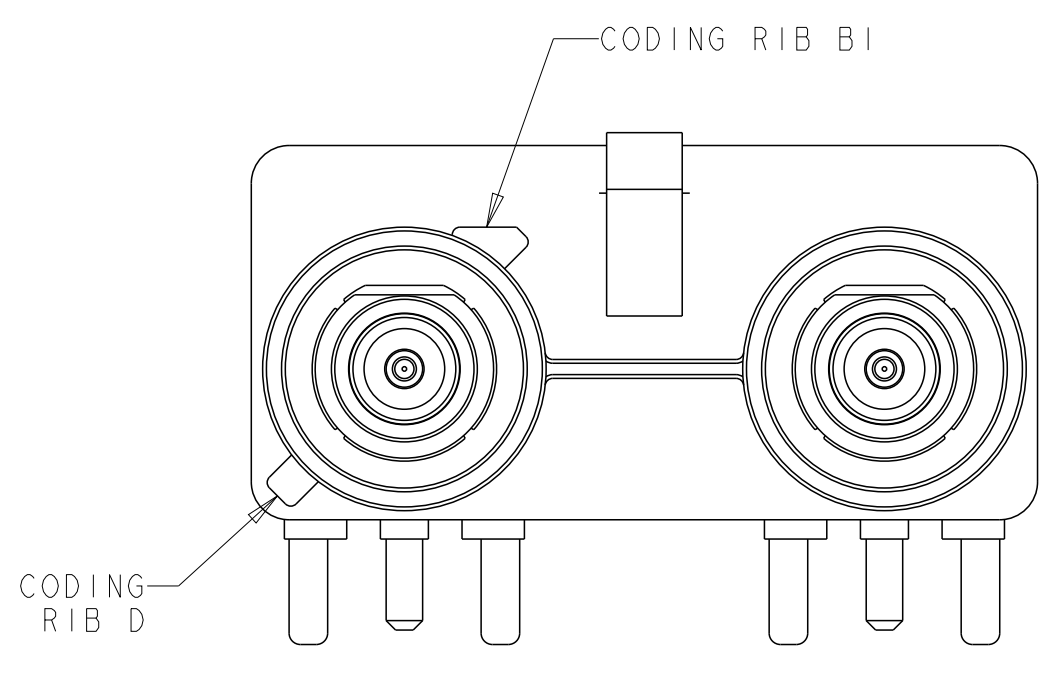

DETAIL W

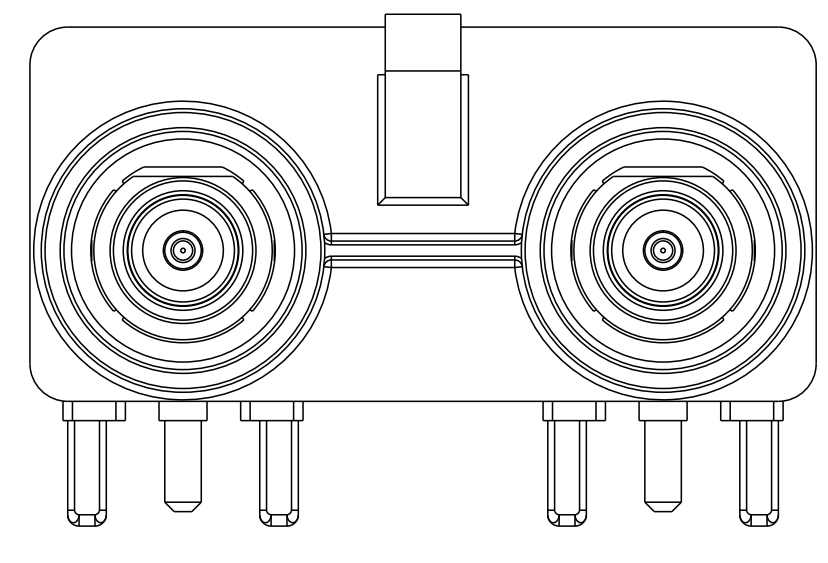

DETAIL Z

<small>THIS DRAWING IS UNPUBLISHED. RELEASED FOR PUBLICATION 20. COPYRIGHT 20 BY TYCO ELECTRONICS CORPORATION. ALL RIGHTS RESERVED.</small>		DWN D. HARDY 05JUL00 CHK J.W. HALL 06JUL00 APVD J.W. HALL 06JUL00	Tyco Electronics Harrisburg, PA 17105-3608
DIMENSIONS: mm 		TOLERANCES UNLESS OTHERWISE SPECIFIED: 0 PLC ± 1 PLC ± 2 PLC ±0.25 3 PLC ± 4 PLC ± ANGLES ± FINISH	NAME JACK ASSEMBLY, FAKRA, 2 POSITION, RIGHT ANGLE, PCB, 50 Ohm, SMB PRODUCT SPEC APPLICATION SPEC SIZE CAGE CODE DRAWING NO. RESTRICTED TO A 00779 C=638818
MATERIAL FINISH		WEIGHT CUSTOMER DRAWING	SCALE 5:1 SHEET 2 OF 2 REV K1