

FS1027-DG

Gas Flow Sensor Module

The FS1027-DG Gas Flow Sensor Module measures the flow rate using the thermo-transfer (calorimetric) principle.

The FS1027-DG offers key advantages over resistor-based flow solutions. The sensor utilizes thermopile sensing, which provides an excellent signal-to-noise ratio. The sensor comprises a “solid” thermal isolation technology with protective coating.

The FS1027-DG provides calibrated linear output through digital I²C and analog interface.

FS1027-DG Module Picture



Features

- Gas flow: 0 to 200 liters/min (in nitrogen or air)
- Robust “solid” isolation technology
- Resistant to vibration and pressure shock
- Minimal flow resistance
- Fast response: < 5ms
- Digital I²C output
- Analog voltage output
- Supply voltage: 5V

Applications

- Ventilators
- Gas metering equipment
- Process controls and monitoring



COMPONENT

Contents

1. Pin Information	3
1.1 Pin Assignments	3
1.2 Pin Descriptions	3
2. Specifications	4
2.1 Absolute Maximum Ratings	4
2.2 Recommended Operating Conditions	4
2.3 Electrical Specifications	4
3. Flow Graphs	5
4. I²C Sensor Interface	6
4.1 Sensor Slave Address	6
4.2 I ² C Communication	6
4.3 Digital Output Measurements	7
4.4 Calculating Flow Output	7
4.5 Calculating Checksum	8
5. Electrical Connector	8
6. Module Material	8
7. Tubing Guidance	8
8. Package Outline Drawings	9
9. Ordering Information	9
10. Revision History	9

1. Pin Information

1.1 Pin Assignments

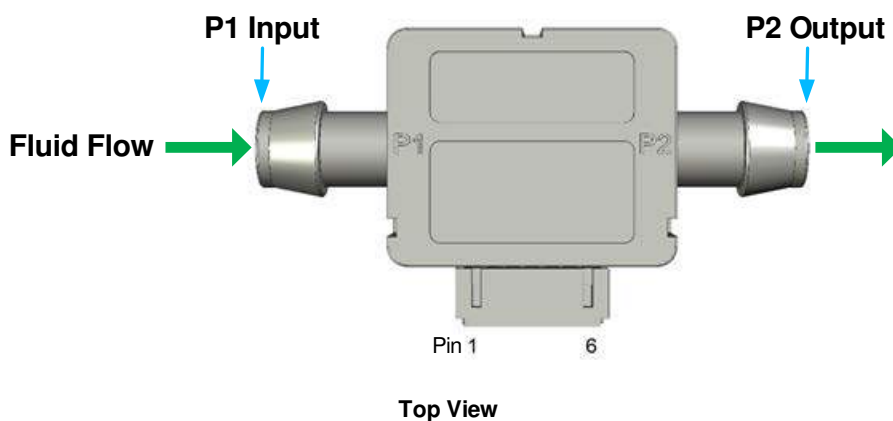

1.2 Pin Descriptions

Pin Number	Pin Name	Description
1	VDD	Supply voltage.
2	GND	Ground.
3	OUTPUT	Flow analog output.
4	SDA	Serial data.
5	SCL	Serial clock.
6	NC	Do not connect. ^[1]

1. "NC" stands for not connected / no connection required / not bonded.

2. Specifications

2.1 Absolute Maximum Ratings

CAUTION: Do not operate at or near the maximum ratings listed for extended periods of time. Stresses greater than those listed below can cause permanent damage to the device. Functional operation of the FS1027-DG at absolute maximum ratings is not implied. Exposure to such conditions can adversely impact product reliability and result in failures not covered by warranty.

Symbol	Parameter	Conditions	Minimum	Maximum	Unit
V_{IN}	Supply Voltage	-	2.7	5.5	V
T_{STOR}	Storage Temperature	-	0	105	°C

2.2 Recommended Operating Conditions

Symbol	Parameter	Minimum	Typical	Maximum	Unit
V_{IN}	Supply Voltage	-	5	-	V
T_{AMB}	Ambient Operating Temperature (in air)	0	25	85	°C
P_{CM}	Common-Mode Pressure	-	-	30	PSI

2.3 Electrical Specifications

Symbol	Parameter	Conditions	Minimum	Typical	Maximum	Unit
I_{VIN}	Current Consumption	-	-	21	-	mA
F_{LQ}	Gas Flow Range	Tested with nitrogen or air, room temperature	0	-	200	Liters/min
V_{AOUT}	Analog Output	At 0 liters/min	-	0.5	-	V
		At 200 liters/min	-	4.5	-	
V_{DOUT}	Digital Output	At 0 liters/min	-	409	-	Counts
		At 200 liters/min	-	3686	-	
E_{Flow}	Flow Accuracy ^[1]	-	-	1.5	5	% Reading
τ_H	Flow Response Time ^[2]	-	-	5	-	msec

1. Calibration Standard Condition: 25°C, 1bar, nitrogen gas.
2. The flow response time includes a 10% to 90% rise time for the flow sensor to electrically respond to any gas flow change. Measurements might be affected by the pneumatic interface.

3. Flow Graphs

The graphs in Figure 1 and Figure 2 shows the digital and analog output versus flow, at 25°C, with nitrogen.

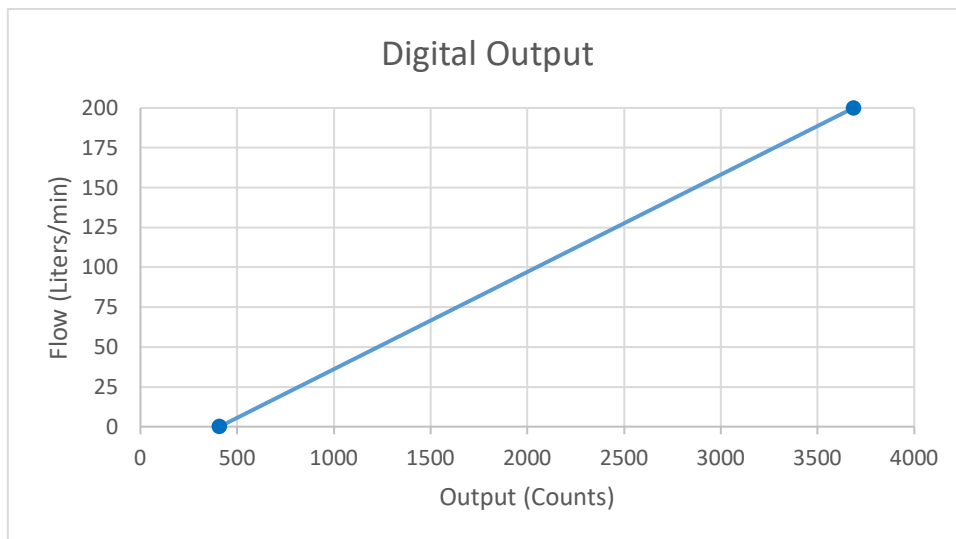

Flow (Liters/min)	Digital Output (Counts)
0	409
200	3686

Figure 1. Digital Output

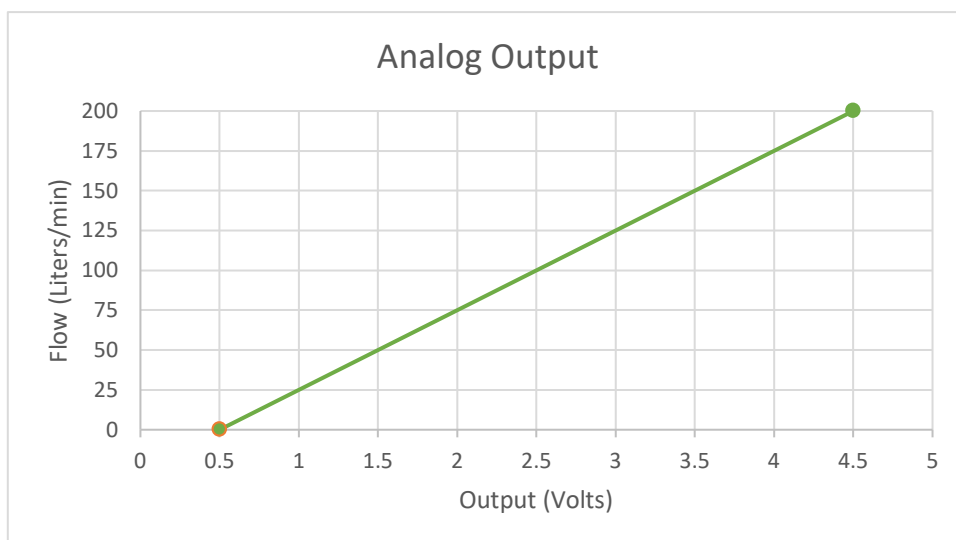

Flow (Liters/min)	Analog Output (Volts)
0	0.5
200	4.5

Figure 2. Analog Output

4. I²C Sensor Interface

The FS1027-DG includes a digital I²C two-wire interface with a bidirectional data line (SDA) and a clock line (SCL). The two lines are open drain and connected to the supply voltage via two pull-up resistors (R_p). The FS1027-DG operates as a slave device on the I²C bus with support of 100kHz and 400kHz bit rates.

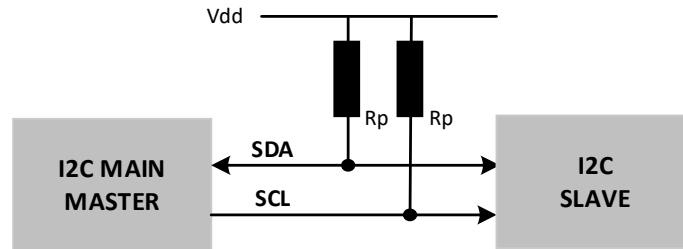

Figure 3. I²C Master-Slave Configuration

The recommended pull-up resistor (R_p) values depend on the system implementation, but a value between 2.2k Ω and 10k Ω can be used.

The capacitive load on both SDA and SCL should be the same, hence the signal lengths should be similar to avoid asymmetry.

4.1 Sensor Slave Address

The FS1027-DG default I²C address is **50_{HEX}**. The device will respond only to this **7-bit address**.

4.2 I²C Communication

The START condition is used to initiate I²C communication by the master. The sensor transmission is initiated when the master sends a 0 START bit (S). A HIGH to LOW transition on the SDA line while the SCL is HIGH indicates the beginning of a transmission.

The STOP condition is used to stop I²C communication by the master. The transmission is terminated when the master sends a 1 STOP bit (P). A LOW to HIGH transition on the SDA line while the SCL is HIGH indicates the end of a transmission.

All transfers consist of 8 bits and a response bit: 0 for Acknowledge (ACK) or 1 for Not Acknowledge (NACK). After the ACK is received, another data byte can be transferred or the communication can be stopped with a STOP bit.

The master expects an ACK back from the slave after each byte is transmitted. The slave pulls the SDA low to indicate that it has received a byte and then it frees the I²C bus again. If the slave does not initiate an ACK, then it will consider it a NACK.

Data on the SDA line is always sampled on the rising edge of the SCL line and must remain stable while SCL is HIGH to prevent false START or STOP conditions.

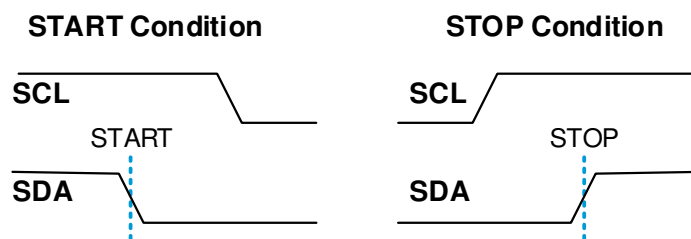

Figure 4. START and STOP Condition Waveform

4.3 Digital Output Measurements

The FS1027-DG continuously measures in operation. The data is sent in byte packages. Each byte is followed by an ACK from the slave. The most significant bit (MSB) is transmitted first.

To read the data, the following command is sent to the FS1027-DG.

After the START bit, the master device sends the 7-bit slave address followed by an eighth bit = 1 (READ). The READ bit indicates a transmission from the FS1027-DG (slave) to master (see Figure 5).

The checksum used for data integrity is returned from the FS1027-DG followed by the two bytes of flow data.

The flow data is a 12-bit integer. Only the least significant four bits in the high byte are valid (see Figure 6).

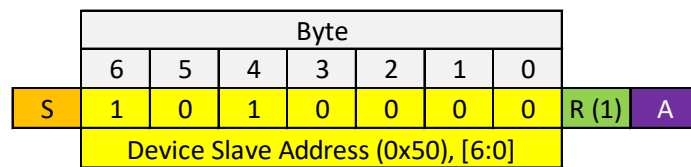

Figure 5. Flow Data Read Command

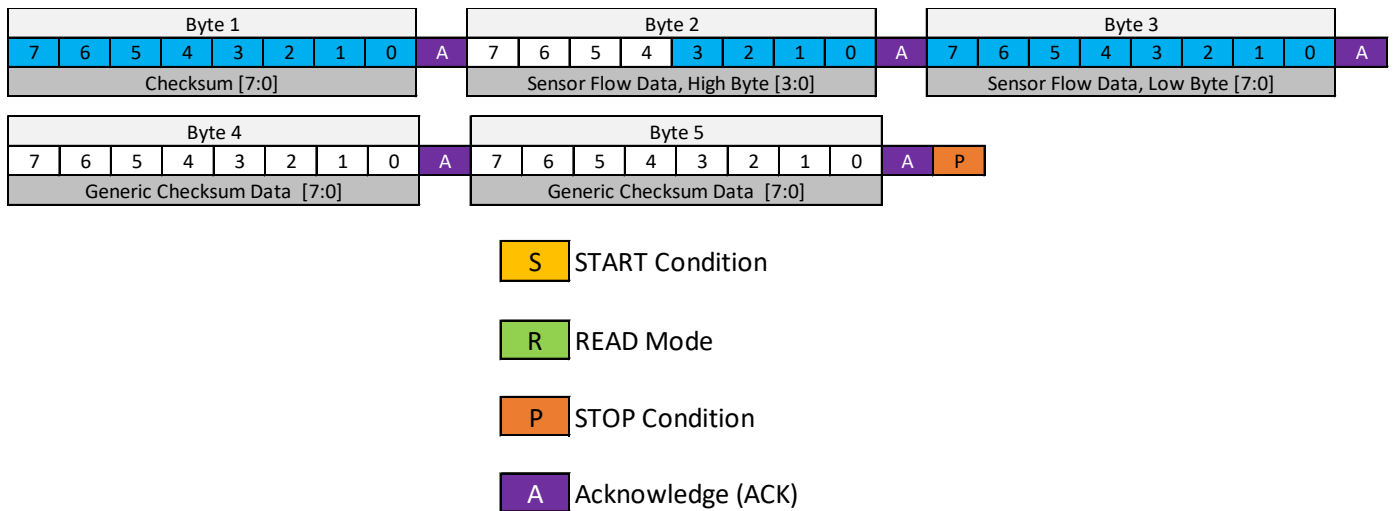

Figure 6. Flow Data from FS1027-DG

4.4 Calculating Flow Output

The flow rate for the digital and analog output are calculated with Equation 1 and Equation 2, respectively.

$$Flow\ rate\ (liters/min) = \frac{Output\ (counts) - 409}{3277} * 200 \tag{Equation 1}$$

$$Flow\ rate\ (liters/min) = \frac{Output\ (analog) - 0.5}{4} * 200 \tag{Equation 2}$$

4.5 Calculating Checksum

The checksum used for data integrity is the 2's complement (negative) of the 256-modulo (8-bit) sum of the data bytes (does not include I²C address).

Figure 6 shows the 5 bytes read:

Example:

Byte 1, 0xCC (Checksum)

Byte 2, 0x01

Byte 3, 0x99

Byte 4, 0x01 or 0x00

Byte 5, 0x99 or 0x00

The 256-modulo (8-bit) sum is calculated as:

$$sum = 0x01 + 0x99 + 0x01 + 0x99 = 0x134$$

Validating the data payload is done by calculating the sum and adding it to the checksum. If the result is 0x00, then the data is valid.

$$checksum + sum = 0xCC + 0x134 = 0x00$$

5. Electrical Connector

A 6-position receptacle (not provided) is required to mate to the board crimp style connector. A part number example is PHR-6 (JST).

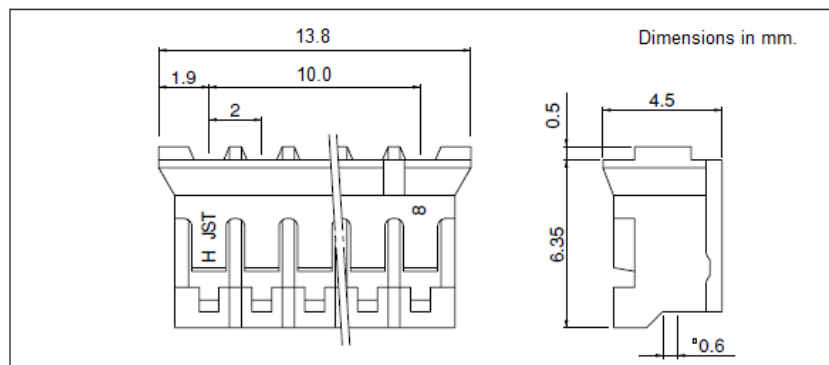

Figure 7. Receptacle Drawing

6. Module Material

The wetted contact surface of the FS1027-DG consists of the following:

- Housing – Polyphenylene Ether (PPE) + Polystyrene (PS) blend resin
- Parylene
- Gasket – Silicone

7. Tubing Guidance

The FS1027-DG module has barb tube endings. Soft tubing with a nominal 5/8-inch (15.88mm) internal diameter is recommended for use. A clamp may be necessary to secure the tubing over the barb.

8. Package Outline Drawings

The package outline drawings are located at the end of this document and are accessible from the Renesas website (see Ordering Information for POD links). The package information is the most current data available and is subject to change without revision of this document.

9. Ordering Information

Part Number	Package Description	Carrier Type	Temperature Range
FS1027-1001-DG	0 to 200 liter/min gas flow sensor module with digital and analog voltage output (MOD0D1)	Box	0°C to +85°C

10. Revision History

Revision	Date	Description
1.02	Sep 6, 2022	<ul style="list-style-type: none"> ▪ Updated reference with nitrogen gas. ▪ Reformatted to the latest template.
1.01	Sep 25, 2020	Updated flow accuracy spec, flow output charts, and checksum example.
1.00	Apr 28, 2020	Initial release.

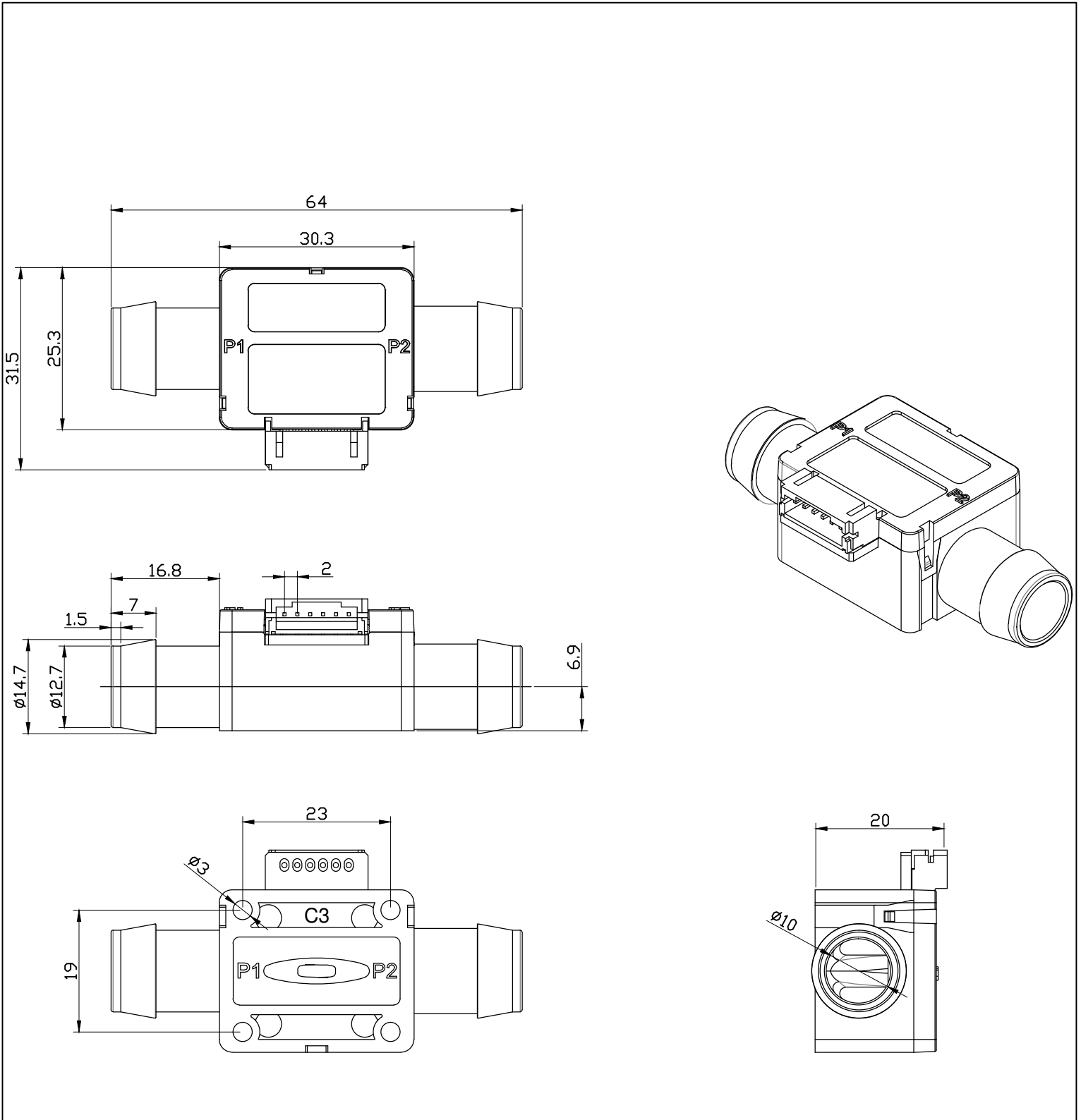

Package Revision History		
Date Created	Rev No.	Description
Nov 28, 2017	Rev 00	Initial Release

IMPORTANT NOTICE AND DISCLAIMER

RENESAS ELECTRONICS CORPORATION AND ITS SUBSIDIARIES (“RENESAS”) PROVIDES TECHNICAL SPECIFICATIONS AND RELIABILITY DATA (INCLUDING DATASHEETS), DESIGN RESOURCES (INCLUDING REFERENCE DESIGNS), APPLICATION OR OTHER DESIGN ADVICE, WEB TOOLS, SAFETY INFORMATION, AND OTHER RESOURCES “AS IS” AND WITH ALL FAULTS, AND DISCLAIMS ALL WARRANTIES, EXPRESS OR IMPLIED, INCLUDING, WITHOUT LIMITATION, ANY IMPLIED WARRANTIES OF MERCHANTABILITY, FITNESS FOR A PARTICULAR PURPOSE, OR NON-INFRINGEMENT OF THIRD PARTY INTELLECTUAL PROPERTY RIGHTS.

These resources are intended for developers skilled in the art designing with Renesas products. You are solely responsible for (1) selecting the appropriate products for your application, (2) designing, validating, and testing your application, and (3) ensuring your application meets applicable standards, and any other safety, security, or other requirements. These resources are subject to change without notice. Renesas grants you permission to use these resources only for development of an application that uses Renesas products. Other reproduction or use of these resources is strictly prohibited. No license is granted to any other Renesas intellectual property or to any third party intellectual property. Renesas disclaims responsibility for, and you will fully indemnify Renesas and its representatives against, any claims, damages, costs, losses, or liabilities arising out of your use of these resources. Renesas' products are provided only subject to Renesas' Terms and Conditions of Sale or other applicable terms agreed to in writing. No use of any Renesas resources expands or otherwise alters any applicable warranties or warranty disclaimers for these products.

(Disclaimer Rev.1.0 Mar 2020)

Corporate Headquarters

TOYOSU FORESIA, 3-2-24 Toyosu,
Koto-ku, Tokyo 135-0061, Japan
www.renesas.com

Contact Information

For further information on a product, technology, the most up-to-date version of a document, or your nearest sales office, please visit:
www.renesas.com/contact/

Trademarks

Renesas and the Renesas logo are trademarks of Renesas Electronics Corporation. All trademarks and registered trademarks are the property of their respective owners.