

SECTION A-A
SCALE 4:1

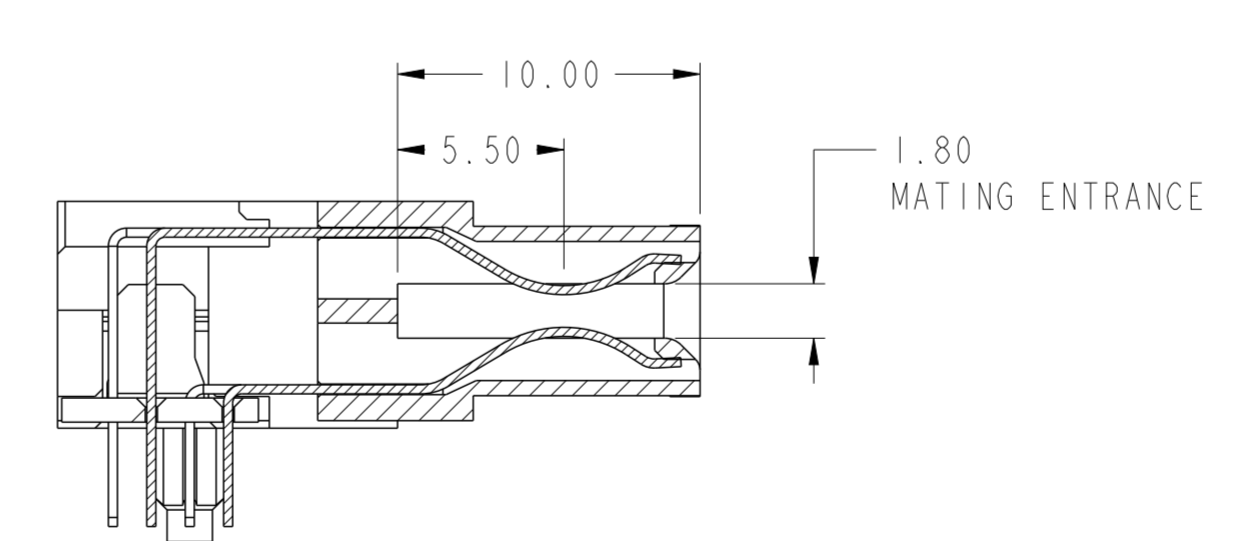

SECTION B-B
SCALE 4:1

REV	DR	DATE
A	JULIA WANG	2013-01-09

spec ref	-	dr	Julia Wang	2012/12/11	projection	MM	size	A2	scale	4:1
tolerance std	ASME Y14.5	eng	Julia Wang	2013/01/09			ecn no	-	rel level	Released
TOLERANCES UNLESS OTHERWISE SPECIFIED		chr	Eleven Hu	2013/01/09						
surface	ASME Y14.5	appr	Pei-Ming Zheng	2013/01/09	product family		dwg no	10123633	rev	A
linear	0.X ±0.5 0.XX ±0.25 0.XXX ±0.10	www.fci.com	cat. no.		Product - Customer Drw		sheet 1 of 4			
angular	0° ±2°									

CONTACT TYPE	TOP LAYER DESCRIPTION	TABLE 1 (HPCE / SOLDER TAILS) PLATED THROUGH-HOLE REQUIREMENTS				
		DRILLED HOLE DIAMETER	COPPER THICKNESS	TIN-LEAD THICKNESS	TIN THICKNESS	FINISHED HOLE DIAMETER
POWER & SIGNAL	TIN-LEAD	1.10-1.16 (1.15 DRILL)	0.025 - 0.050	0.005 - 0.015	--	0.94 - 1.10
	IMMERSION TIN	1.10-1.16 (1.15 DRILL)	0.025 - 0.050	--	0.9 - 1.5um	0.94 - 1.10
	COPPER (SEE NOTE 8)	1.10-1.16 (1.15 DRILL)	0.025 - 0.050	--	--	0.94 - 1.10

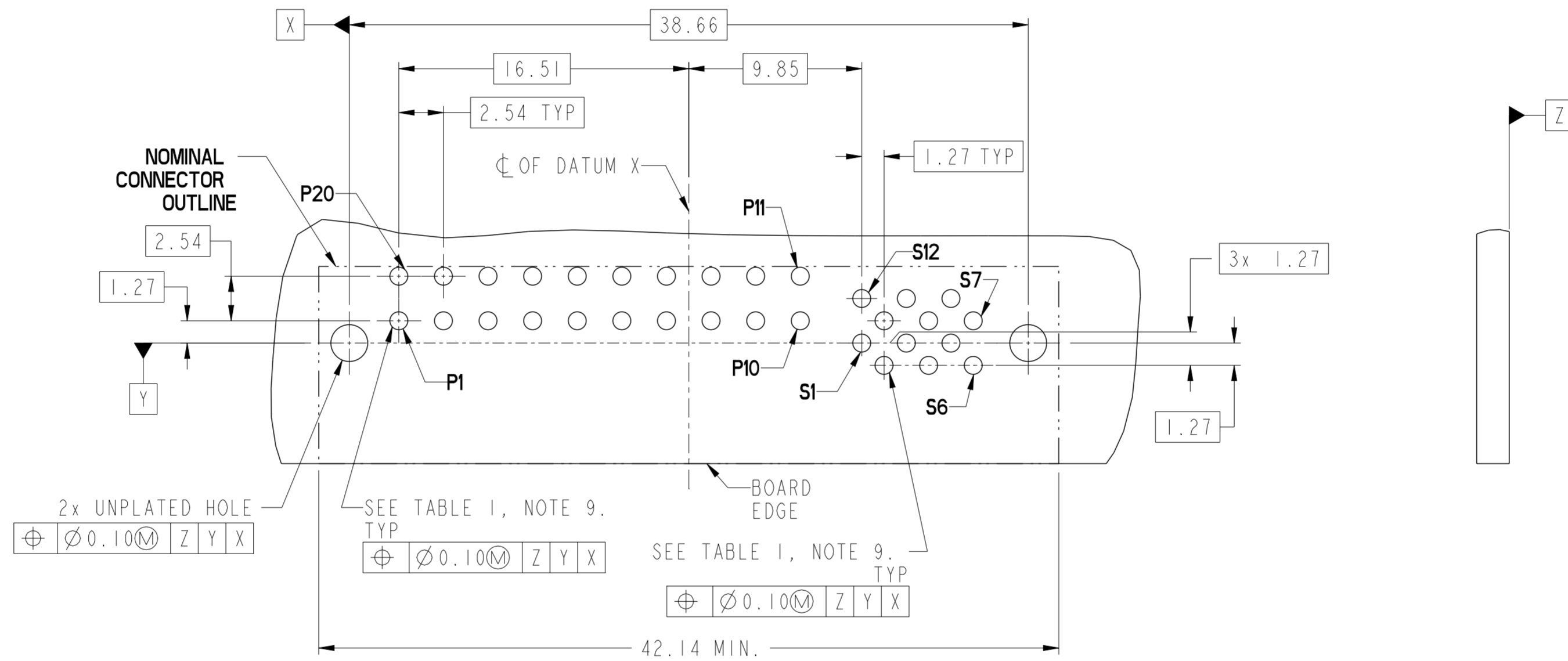

RECOMMENDED PCB LAYOUT

spec ref	-	dr	Julia Wang	2012/12/11	projection	MM	size	A2	scale	4:1
tolerance std	ASME Y14.5	eng	Julia Wang	2013/01/09			ecn no	-	rel level	Released
TOLERANCES UNLESS OTHERWISE SPECIFIED		chr	Eleven Hu	2013/01/09						
		appr	Pei-Ming Zheng	2013/01/09						
surface	<input checked="" type="checkbox"/> linear <input type="checkbox"/> angular	0.X ±0.5 0.XX ±0.25 0.XXX ±0.10 0° ±2°				title R/A RECT (20P-12S) HIGH POWER CARD EDGE	dwg no 10123633	rev A	Product - Customer Drw sheet 2 of 4	
ASME Y14.5		www.fci.com	cat. no.	Product - Customer Drw		sheet 2 of 4				

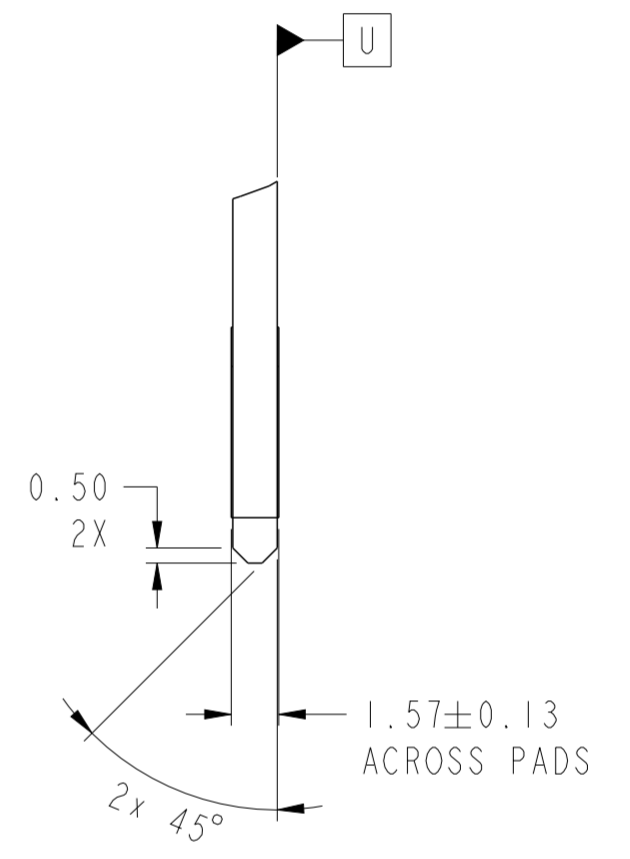
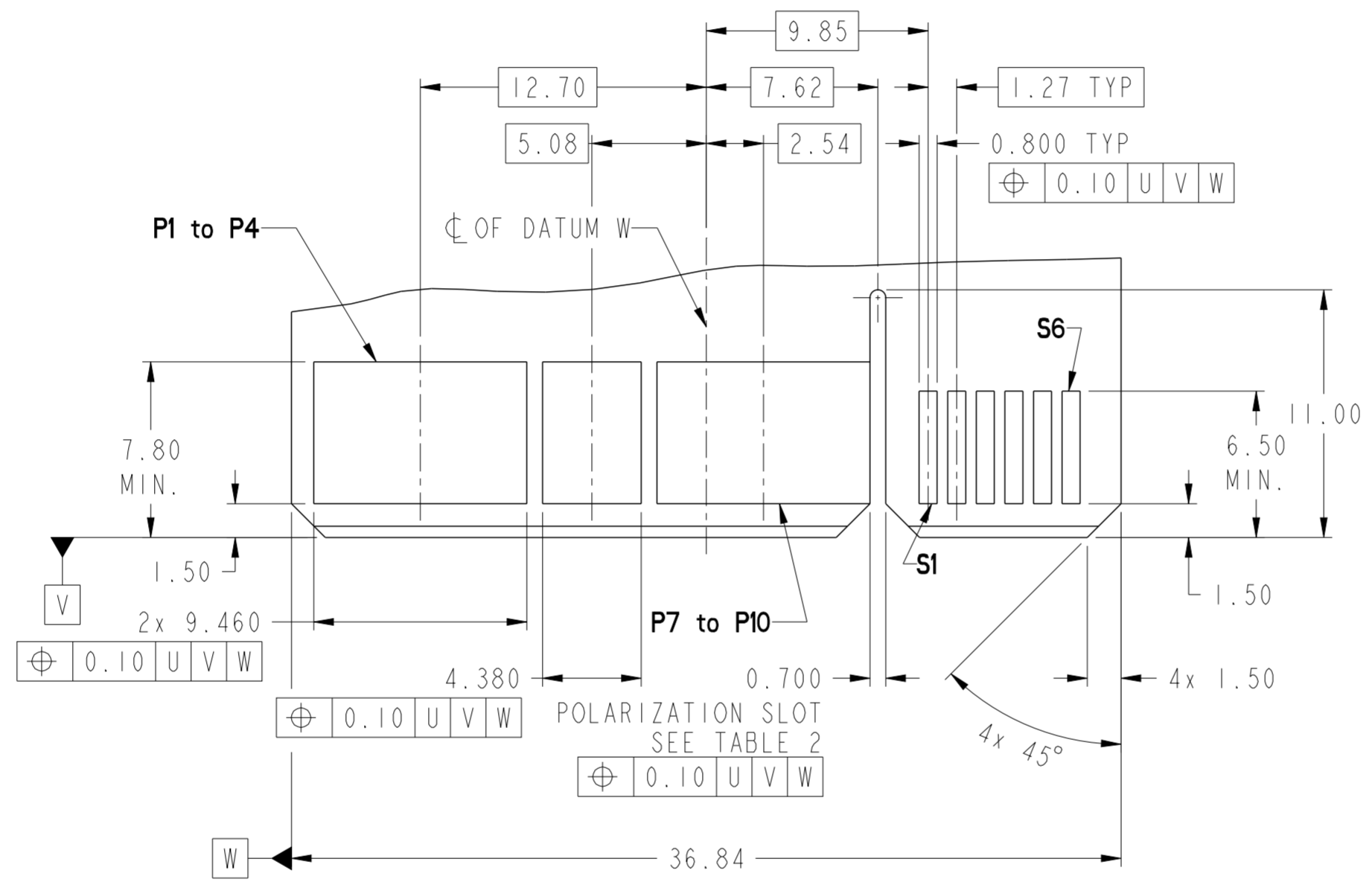

RECOMMENDED MATING BOARD FOOT PRINT

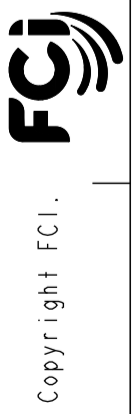

spec ref	-	dr	Julia Wang	2012/12/11	projection	MM	size	A2	scale	4:1	
tolerance std	ASME Y14.5	eng	Julia Wang	2013/01/09			ecn no	-	rel level	Released	
TOLERANCES UNLESS OTHERWISE SPECIFIED		chr	Eleven Hu	2013/01/09							
		appr	Pai-Ming Zheng	2013/01/09							
surface	ASME Y14.5	linear	0.X	±0.5	0.XX	±0.25	0.XXX	±0.10	angular	0°	±2°
				title R/A RECT (20P-12S) HIGH POWER CARD EDGE		dwg no 10123633		rev A			
		www.fci.com		cat. no.		Product - Customer Drw		sheet 3 of 4			

HPCE PART NUMBER (TABLE 2)				
PART NUMBER	TAIL TYPE	HOLD-DOWN OPTION	ORIENTATION KEY	DIM "A" TYPICAL TAIL LENGTH
10123633-001LF	SOLDER TAIL	NO	YES	3.25±0.25
10123633-002LF			NO	
10123633-003LF		YES	YES	
10123633-004LF			NO	
10123633-005LF		NO	YES	2.60±0.25
10123633-006LF			NO	
10123633-007LF		YES	YES	
10123633-008LF			NO	

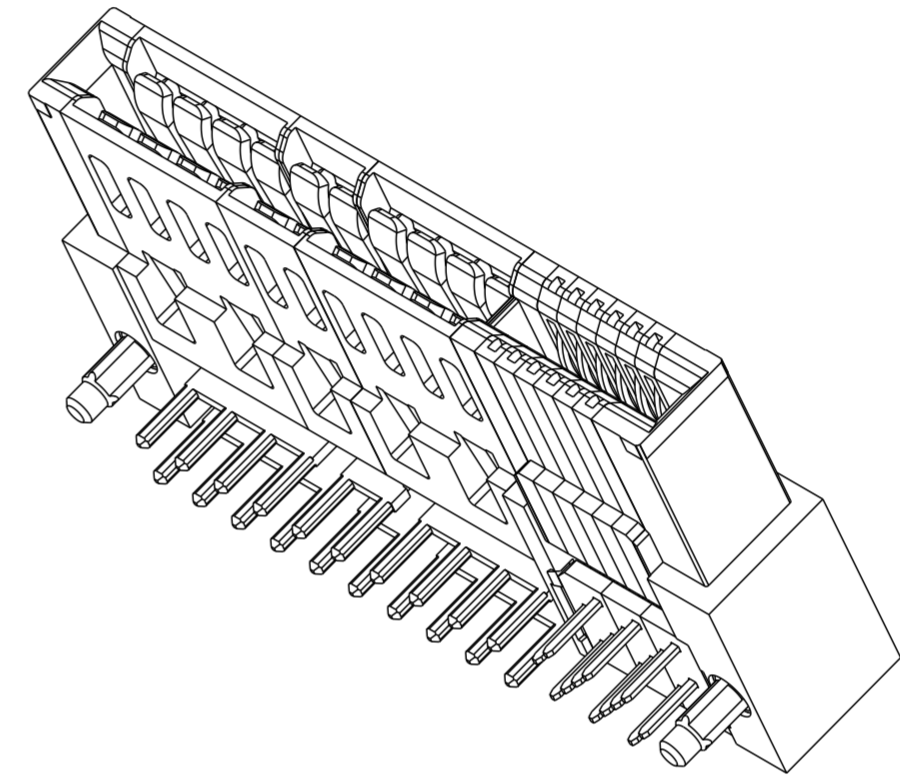

NOTES:

1. CONNECTOR MATERIALS:
 HOUSING: HIGH TEMPERATURE THERMAL PLASTIC, BLACK
 UL 94V-0 COMPLIANT
 CONTACTS: HIGH PERFORMANCE COPPER ALLOY.
2. CONTACT FINISH REF. GS-12-604 SECTION 5.2.
3. PRODUCT SPECIFICATION: GS-12-604.
4. APPLICATION SPECIFICATION: GS-20-128.
5. PRODUCT MARKING (FCI - PART NUMBER & DATE CODE) ON HOUSING IN AREA SHOWN.
6. PACKAGING MEETS FCI SPECIFICATION GS-14-937.
7. HOUSING COMPONENT WILL WITHSTAND EXPOSURE TO 260°C PEAK TEMPERATURE FOR 60 SECONDS IN A CONVECTION, INFRA-RED, OR VAPOR PHASE REFLOW OVEN.
8. COPPER PLATING THICKNESS IN CENTER OF VIA-HOLE CAN BE NO MORE THAN 0.003 LESS THAN OTHER AREAS.
9. ALL HOLE SIZES ARE FINISHED HOLE SIZES.
10. MOUNTING HOLES ARE UNPLATED
 ∅ 2.18 +/- 0.03 FOR SOLDER TAILS

spec ref	-	dr	Julia Wang	2012/12/11	projection	MM	size	A2	scale	4:1										
tolerance std	ASME Y14.5	eng	Julia Wang	2013/01/09			ecn no	-	rel level		Released									
TOLERANCES UNLESS OTHERWISE SPECIFIED		chr	Eleven Hu	2013/01/09			product family			dwg no	10123633	rev	A							
surface	<table border="1"> <tr> <td>linear</td> <td>0.X</td> <td>±0.5</td> </tr> <tr> <td></td> <td>0.XX</td> <td>±0.25</td> </tr> <tr> <td></td> <td>0.XXX</td> <td>±0.10</td> </tr> <tr> <td>angular</td> <td>0°</td> <td>±2°</td> </tr> </table>	linear	0.X	±0.5				0.XX	±0.25		0.XXX	±0.10	angular	0°	±2°	appr	Pei-Ming Zheng	2013/01/09	www.fci.com	cat. no.
linear	0.X	±0.5																		
	0.XX	±0.25																		
	0.XXX	±0.10																		
angular	0°	±2°																		