

DRAWING MADE IN THIRD ANGLE PROJECTION

THIS DRAWING IS UNPUBLISHED. RELEASED FOR PUBLICATION, 19

© COPYRIGHT 19 BY AMP INCORPORATED. ALL INTERNATIONAL RIGHTS RESERVED.

LOC	DIST	P	F	REVISIONS				
				ZONE	LTR	DESCRIPTION	DATE	APPD
AF	50			C		REV AND REDRAWN PER AF-6382	12/12/89	PF/MF

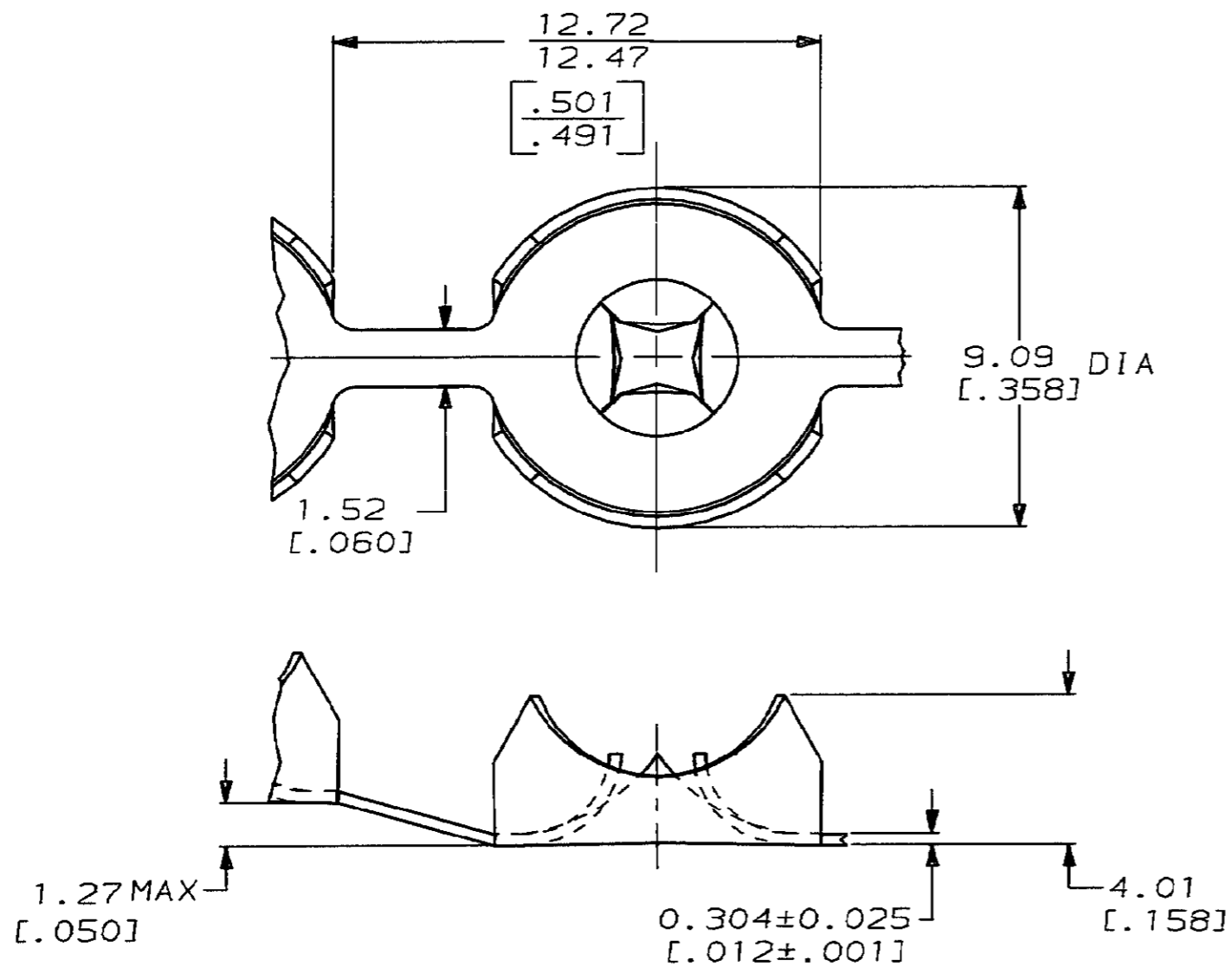

1 CONTINUOUS STRIP ON REELS

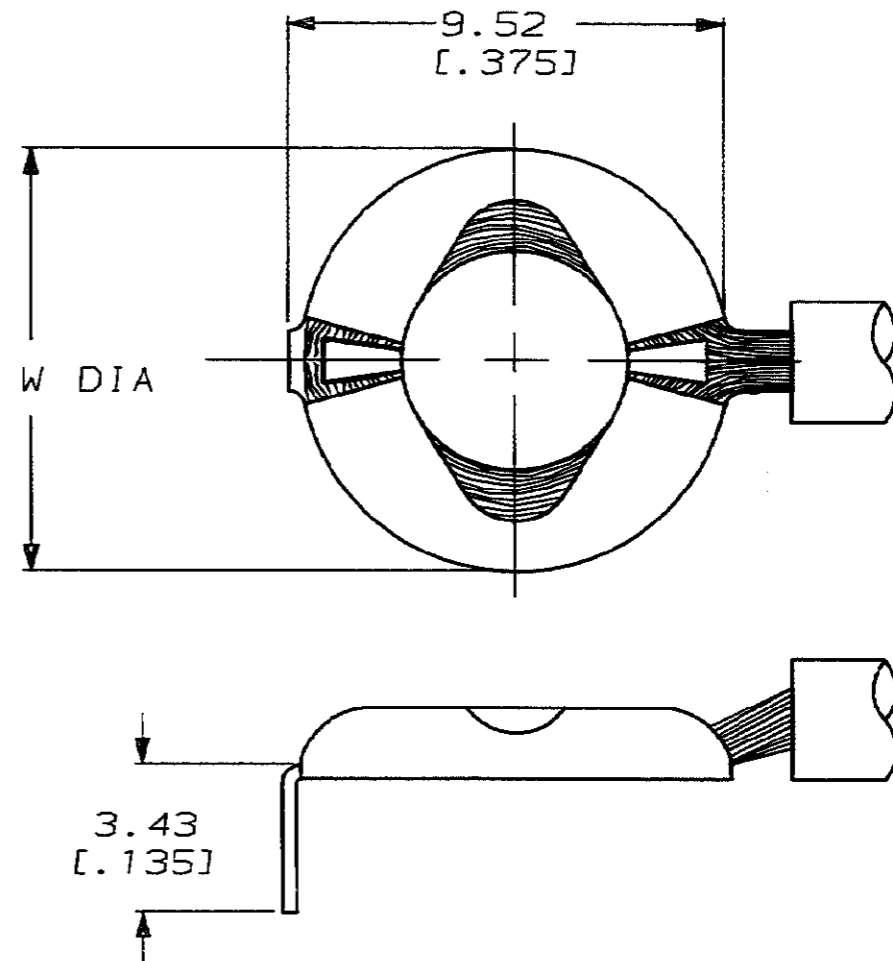

8.84 [.348]	4.57 [.180]	0.8mm <sup>2</sup> - 2.0mm <sup>2</sup>	60238-2
8.84 [.348]	3.94 [.155]	[18-14] AWG	60238-1
W	HOLE DIA ± 0.13 [.005]	WIRE SIZE	PART NO

DO NOT SCALE PRINT. UNLESS SPECIFIED DIMENSIONS IN mm [INCHES] TOLERANCES ON: 2 PLC DEC ± - 3 PLC DEC ± 0.38 [.015] ANGLES ± -	DR 1/26/90 P FORTNEY CHK 1/26/90 MS FEHER APPD 2/2/90 G YETTER APPD 2/2/90 R KUZO PRODUCT SPEC - APPLICATION SPEC - WEIGHT -
MATERIAL #1 HARD BRASS OIL LUBRICATED	FINISH

AMP INCORPORATED Harrisburg, Pa. 17105		
NAME EYELET, CROWN CRIMP		
SIZE <b>B</b>	CAGE CODE 00779	DRAWING NO 60238
SCALE 6:1	SHEET 1 OF 1	

**METRIC**