

PART NUMBER	REV	FIRST USED	POWER UNIT	FEED TYPE
1852085-1	A	122500-1	LEADMAKER & BENCH MODEL G	POST FEED
1852085-2	A	565435-5	BENCH MODEL K	POST FEED

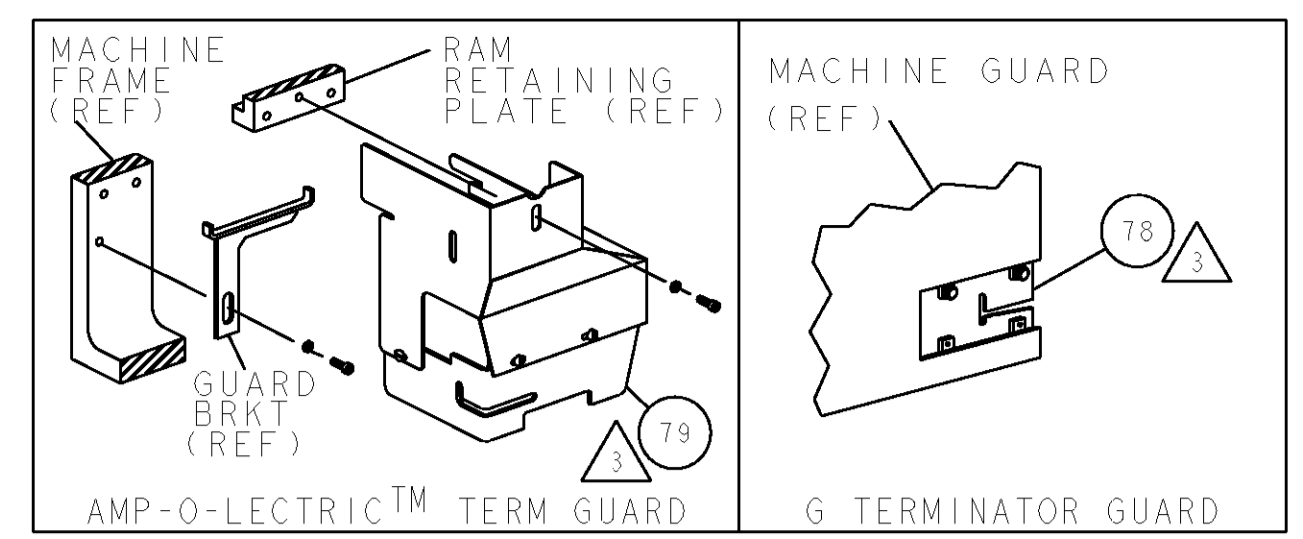

TERMINAL NAME: .250 SERIES FASTON					
TYCO PN	MANF PN	ESCUBEDO TERMINAL - AMP CRIMP SPECS			
1572745	4542.00				
		PAD LTR	CRIMP HEIGHT	WIRE SIZE	
-	-	A	.074±.002[1.88±0.05mm]	14 AWG	
-	-	B	.065±.002[1.65±0.05mm]	16 AWG	
-	-	C	.060±.002[1.52±0.05mm]	18 AWG	
-	-	D	-	-	
		CRIMP	SIZE	TYPE	RANGE
-	-	-	.120 [3.05mm]	F	14-18 AWG
-	-	WIRE	.180 [4.57mm]	F	14-18 AWG
-	-	INSUL	.180 [4.57mm]	F	.118-.170
WIRE STRIP LENGTH	TERM APPL SPEC	FEED	APPL INSTRUCTIONS	SET UP GAGE	
.185-.200	NONE	.750	408-8039	456638-1	

LOC	DIST	REVISIONS				
A	66	P LTR	DESCRIPTION	DATE	BYN	APPD
		A	PRODUCT RELEASE	12AUG05	CMR	TE

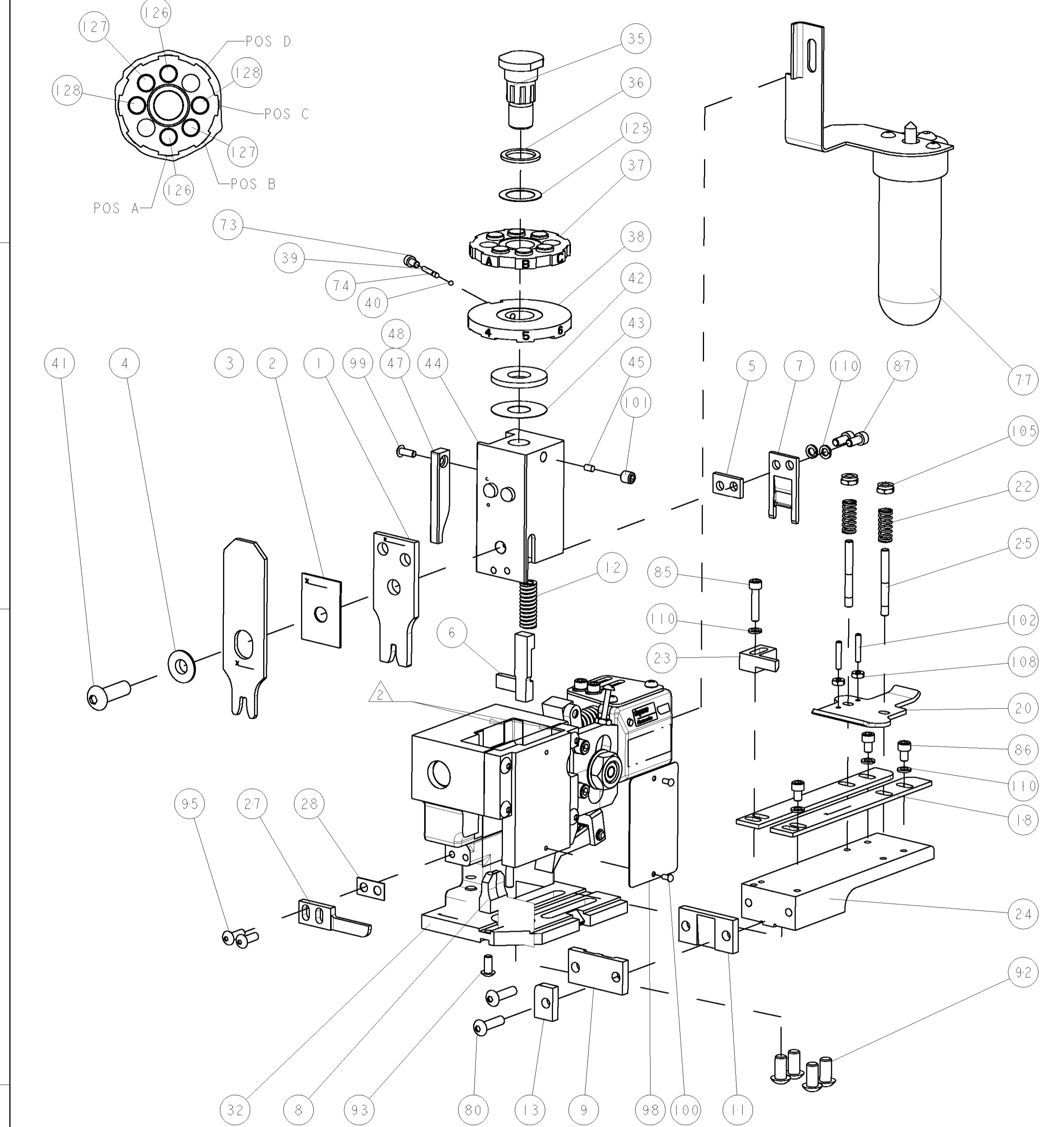

- △ RECOMMENDED SPARE PARTS
- △ GREASE LIGHTLY
- △ GUARD MUST BE IN PLACE WHEN OPERATING APPLICATOR IN A BENCH MACHINE

-	-	-	-	-	129
2	2	-	2-354779-7	PIN, WIRE DISC, .3125	128
2	2	-	1-354779-8	PIN, WIRE DISC, .3080	127
2	2	-	9-354778-5	PIN, WIRE DISC, .2970	126
1	1	-	986950-1	WASHER, FLAT PRECISION	125
1	1	-	217238-1	GENERAL INSTRUCTION PKG	124
1	1	-	4088039	EF APPL INST 408-8039	123
-	-	-	-	-	122
-	-	-	-	-	121
-	-	-	-	-	120
-	-	-	-	-	119
-	-	-	-	-	118
-	-	-	-	-	117
-	-	-	-	-	116
-	-	-	-	-	115
-	-	-	-	-	114
-	-	-	-	-	113
-	-	-	-	-	112
-	-	-	-	-	111
7	7	-	21024-4	WASHER, SPRG LOCK, REG NO 8	110
-	-	-	-	-	109
2	2	-	21018-4	NUT, HEX, REG 4-40	108
-	-	-	-	-	107
-	-	-	-	-	106
2	2	-	21022-2	NUT, LOCK, HEX, TORQUE, 8-32	105
-	-	-	-	-	104
-	-	-	-	-	103
2	2	-	2-21006-6	SCR, SET, CUP POINT 4-40 X .625	102
1	1	-	21009-2	SCR, SET, SELF LOCKING 1/4-20 X .250	101
2	2	-	21017-2	SCREW, DRIVE	100
1	1	-	1-21002-7	SCR, BTN SKT HD CAP 6-32 X .375	99
1	1	-	461264-1	PLATE, IDENTIFICATION	98
-	-	-	-	-	97
-	-	-	-	-	96
2	2	-	2-21002-2	SCR, BTN SKT HD CAP 8-32 X .500	95
-	-	-	-	-	94
1	1	-	22733-8	SCR, BHSC, SELF-LOCKING, 8-32 X .375	93
4	4	-	3-21002-3	SCR, BTN SKT HD CAP 1/4-20 X .500	92
-	-	-	-	-	91
-	-	-	-	-	90
-	-	-	-	-	89
-	-	-	-	-	88
2	2	-	2-21000-6	SCR, SKT HD CAP 8-32 X .375	87
3	3	-	2-21000-5	SCR, SKT HD CAP 8-32 X .250	86
2	2	-	2-21000-9	SCR, SKT HD CAP 8-32 X .750	85
-	-	-	-	-	84
-	-	-	-	-	83
-	-	-	-	-	82
-	-	-	-	-	81
2	2	-	2-21002-9	SCR, BTN SKT HD CAP 10-32 X .750	80
REF	-	-	455745-1	GUARD WINDOW	79
-	REF	-	679532-1	INSERT, GUARD	78
1	1	-	465184-9	LUBRICATOR ASSY	77
-	-	-	-	-	76
-	-	-	-	-	75
1	1	-	690603-1	SPRING ASSIST AMP-O-MATOR APPLICATOR	74
-2	-1	U/M	PART NO	DESCRIPTION	ITEM NO

-	-	-	-	-	73
-	-	-	-	-	72
-	-	-	-	-	71
-	-	-	-	-	70
-	-	-	-	-	69
-	-	-	-	-	68
-	-	-	-	-	67
-	-	-	-	-	66
-	-	-	-	-	65
-	-	-	-	-	64
-	-	-	-	-	63
-	-	-	-	-	62
-	-	-	-	-	61
-	-	-	-	-	60
-	-	-	-	-	59
-	-	-	-	-	58
-	-	-	-	-	57
-	-	-	-	-	56
-	-	-	-	-	55
-	-	-	-	-	54
-	-	-	-	-	53
-	-	-	-	-	52
-	-	-	-	-	51
-	-	-	-	-	50
-	-	-	-	-	49
1	-	-	690501-3	CAM, POST FEED, 1 1/8	48
-	1	-	690501-4	CAM, POST-FEED 1 5/8	47
-	-	-	-	-	46
1	1	-	690191-1	PLUG, NYLON	45
1	1	-	455674-1	RAM	44
1	1	-	690125-1	SHIM SUB-ASSY	43
1	1	-	690124-1	WASHER, RAM (.115)	42
1	1	-	7-21002-9	SCR, BTN SKT HD CAP 5/16-24 X 1.00	41
1	1	-	23241-6	BALL, STEEL	40
1	1	-	690170-1	SPRING, COMPRESSION	39
1	1	-	690142-1	DISC, INSULATION	38
1	1	-	354777-1	WIRE DISC, ASSEMBLY	37
1	1	-	22480-5	SPRING, COMPRESSION	36
1	1	-	690212-1	POST, RAM	35
-	-	-	-	-	34
-	-	-	-	-	33
1	1	-	458980-1	SUB ASSY, APPLICATOR FRAME	32
-	-	-	-	-	31
-	-	-	-	-	30
-	-	-	-	-	29
1	1	-	1-690451-7	SPACER, STRIPPER	28
1	1	-	240639-1	STRIPPER (MACHINING)	27
-	-	-	-	-	26
2	2	-	22354-8	STUD, THREADED	25
1	1	-	455678-1	PLATE, STRIP GUIDE	24
1	1	-	240825-2	PLATE, STRIP HOLD DOWN	23
2	2	-	4-22281-1	SPRING, DRAG	22
-	-	-	-	-	21
1	1	-	454177-1	DRAG	20
-	-	-	-	-	19
1	2	-	454204-3	GUIDE, LOWER STRIP	18
-	-	-	-	-	17
-	-	-	-	-	16
-	-	-	-	-	15
-	-	-	-	-	14
△	1	1	690481-2	SPACER, HOLD DOWN	13
1	1	-	23846-1	SPRING, DIE	12
1	1	-	240644-1	PLATE, REAR SHEAR	11
-	-	-	-	-	10
△	1	1	690482-5	PLATE, FRONT SHEAR	9
△	1	1	1633249-1	ANVIL, COMBINATION	8
1	1	-	690474-5	BLADE, SLUG	7
1	1	-	1-455692-1	HOLD DOWN, TERMINAL	6
1	1	-	240641-2	SPACER	5
1	1	-	238009-4	BLOCK, FL CRIMPER SPACER	4
1	1	-	1-1213077-0	CRIMPER, INSULATION PREMIUM	3
1	1	-	455888-8	SPACER, CRIMPER	2
△	1	1	456409-3	CRIMPER, WIRE .120 "F" PREMIUM	1

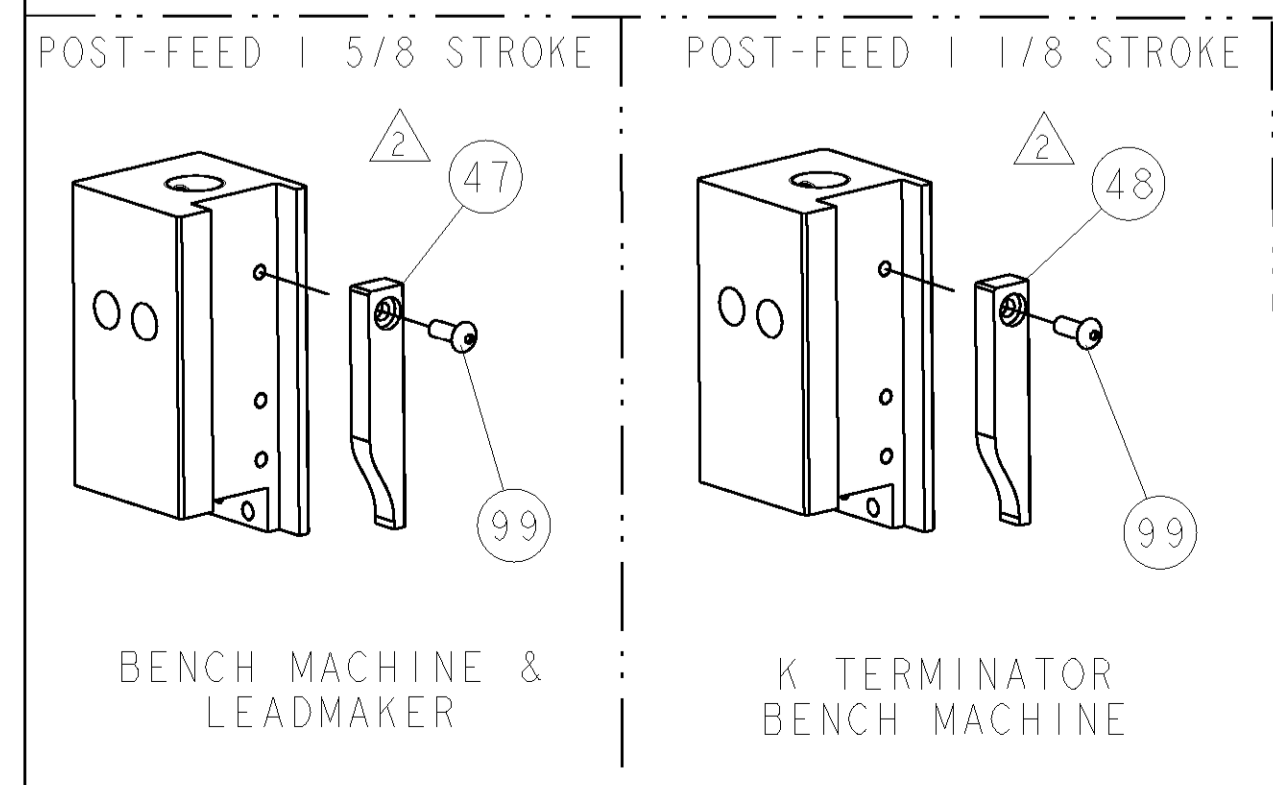

DIMENSIONS:		TOLERANCES UNLESS OTHERWISE SPECIFIED:	
INCHES	0 PLC ±.01	1 PLC ±.01	2 PLC ±.01
	3 PLC ±.001	4 PLC ±.0001	ANGLES ±.001
MATERIAL:		FINISH:	

APPROVED:	DATE:	BY:	DATE:
C. REICHELDECKER	19 JULY 05	T. ELBIN	19 JULY 05
CUSTOMER DRAWING		SCALE 3:5 SHEET 1 OF 1 REV A	

TYCO Electronics	Tyco Electronics
Harrisburg, PA 17105-3608	Harrisburg, PA 17105-3608
PRODUCT SPEC	NAME
1 BENCHOFF	SIDE FEED HDM APPLICATOR
APPLICATION SPEC	SIZE
	A11 00779 C=1852085

CUSTOMER VIEWABLE ASSEMBLY