

PRODUCT NUMBER
SEE TABLE

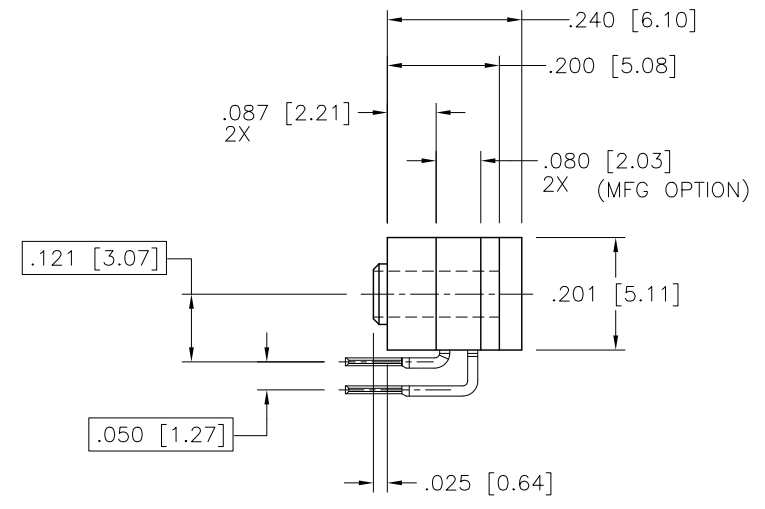

mat'l. code				surface		tolerance		projection		product family	
-				ISO 1302 \checkmark		ISO 406 ISO 1101				RIBCAGE	
ltr	ecn no	dr	date	tolerances unless otherwise specified						title	
H	M05-0123	MHT	6/07/05	angles	linear	.XX \pm .01/0.3		INCH/MM		RIBCAGE HORIZONTAL HEADER ASSEMBLY	
J	M05-0196	MHT	9/13/05			.xxx \pm .005/0.13					
K	M06-0225	ERE	06/12/06	0° \pm x°		.xxx \pm .0020/0.05		scale 3:1			
L	M06-0370	MHT	9/26/06	dr	M. CORNMAN	6/6/95				dwg no sheet 1 of 4 size	
M	M09-0058	MHT	4/02/09	engr	D. WHITING	6/6/95				95780 A3	
N	N10-0122	YO	5/11/10	chr	D. WHITING	6/6/95					
P	ELX-N-009981	YO	1/30/12	appd	D. WHITING	6/6/95				type Product Customer Drawing	
sheet	revision	P	P	P	P						
index	sheet	1	2	3	4						

PRODUCT NUMBER
SEE TABLE

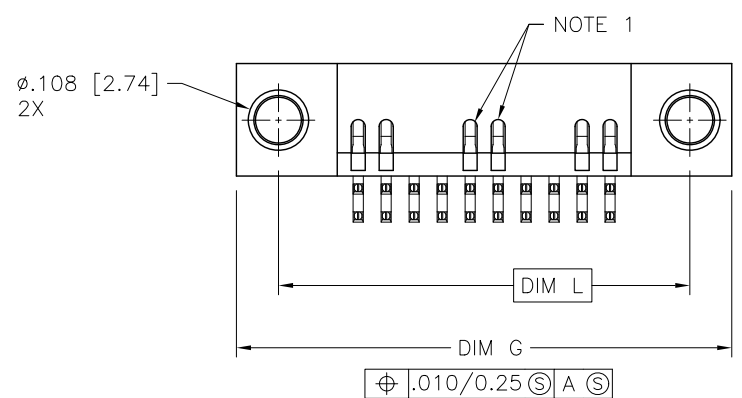
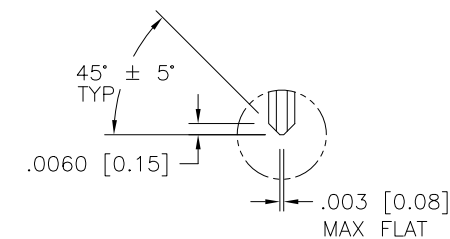
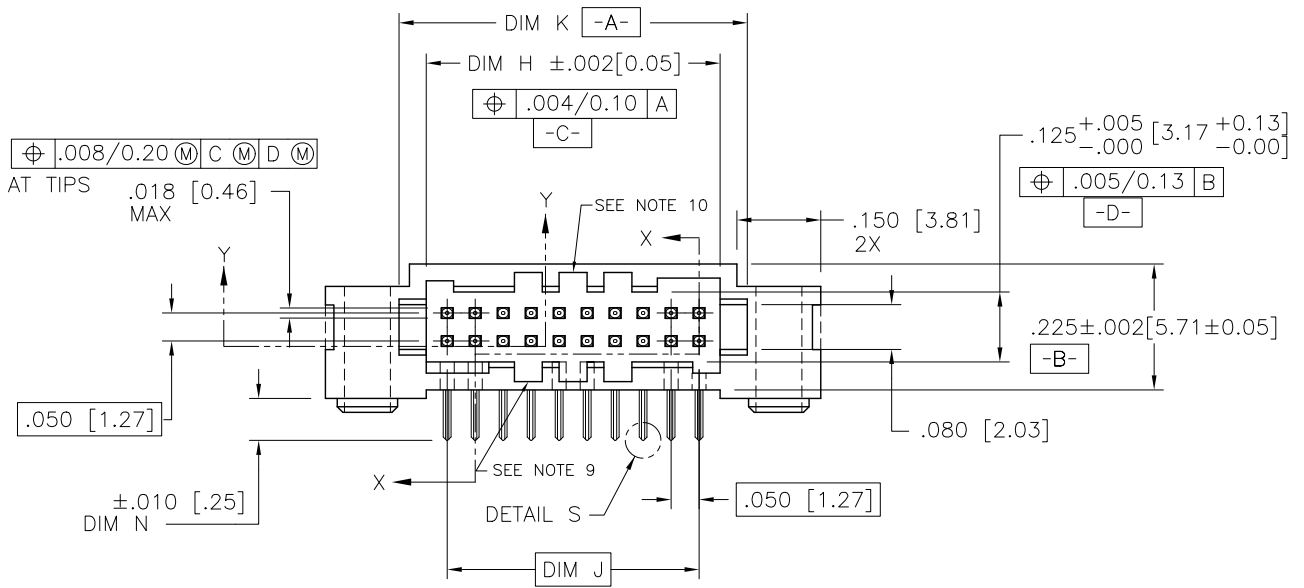
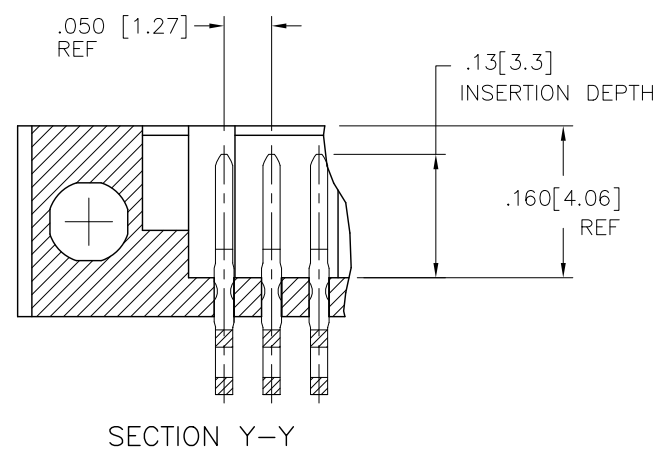
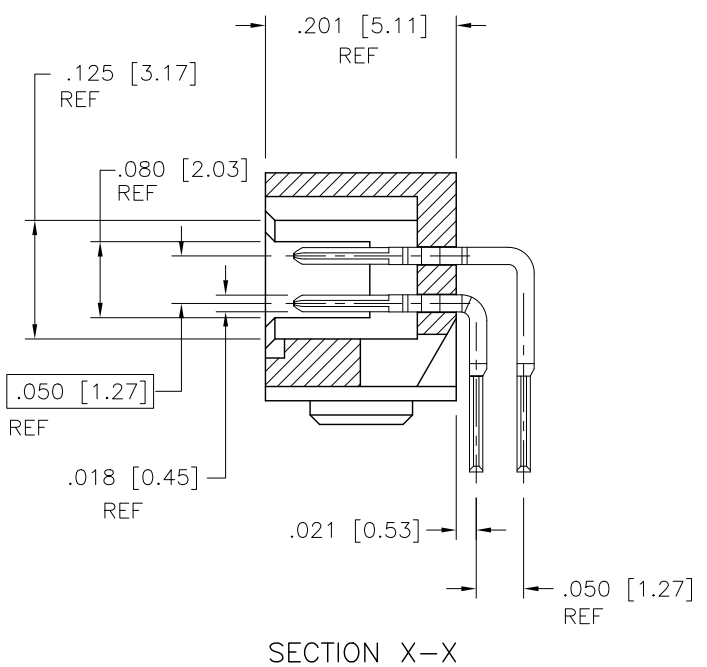

FCI
FCIconnect.com

Copyright FCI

mat'l. code -		surface ISO 1302 ✓	tolerance ISO 406 ISO 1101	projection [Symbol]	product family RIBCAGE
ltr	ecn	no	dr	date	tolerances unless otherwise specified
P					angles linear .XX±.01/0.3 .XXX±.005/0.13 0.001±.0020/0.051
					INCH/MM
					scale 3:1
			dr	M. CORNMAN	6/6/95
			enr	D. WHITING	6/6/95
			chr	D. WHITING	6/6/95
			appd	D. WHITING	6/6/95
sheet index		revision sheet		[Grid]	

title
**RIBCAGE HORIZONTAL
HEADER ASSEMBLY**

FCI

dwg no 95780 sheet 2 of 4 size A3

type Product Customer Drawing

PRODUCT NO. NOTE 5,6	SIZE	DIM G	DIM H	DIM J	DIM K	DIM L	TAIL LENGTH DIM N
87402 OR 93120 -105	2X5	.635/16.13	.275/6.90	.200/5.08	.380/9.65	.485/12.32	.075/1.90
-110	2X10	.885/22.48	.525/13.34	.450/11.43	.630/16.00	.735/18.67	
-115	2X15	1.135/28.83	.775/19.68	.700/17.78	.880/22.35	.985/25.02	
-120	2X20	1.385/35.18	1.025/26.03	.950/24.13	1.130/28.70	1.235/31.37	
-125	2X25	1.635/41.52	1.275/32.38	1.200/30.48	1.380/35.05	1.485/37.72	
-130	2X30	1.885/47.88	1.525/38.74	1.450/36.83	1.630/41.40	1.735/44.07	
-135	2X35	2.135/54.23	1.775/45.08	1.700/43.18	1.880/47.75	1.985/50.42	
-140	2X40	2.385/60.58	2.025/51.43	1.950/49.53	2.130/54.10	2.235/56.77	
-145	2X45	2.635/66.93	2.275/57.78	2.200/55.88	2.380/60.45	2.485/63.12	
-150	2X50	2.885/73.28	2.525/64.14	2.450/62.23	2.630/66.80	2.735/69.47	.075/1.90
-150N	2X50	2.885/73.28	2.525/64.14	2.450/62.23	2.630/66.80	2.735/69.47	.125/3.18
-305	2X5	.635/16.13	.275/6.90	.200/5.08	.380/9.65	.485/12.32	.085/2.16
-310	2X10	.885/22.48	.525/13.34	.450/11.43	.630/16.00	.735/18.67	
-320	2X20	1.385/35.18	1.025/26.03	.950/24.133	1.130/28.70	1.235/31.37	
-330	2X30	1.885/47.88	1.525/38.74	1.450/36.83	1.630/41.40	1.735/44.07	
-345	2X45	2.635/66.93	2.275/57.78	2.200/55.88	2.380/60.45	2.485/63.12	.085/2.16
-510	2X10	.885/22.48	.525/13.34	.450/11.43	.630/16.00	.735/18.67	.125/3.18
-515	2X15	1.135/28.83	.775/19.68	.700/17.78	.880/22.35	.985/25.02	
-520	2X20	1.385/35.18	1.025/26.03	.950/24.13	1.130/28.70	1.235/31.37	
-525	2X25	1.635/41.52	1.275/32.38	1.200/30.48	1.380/35.05	1.485/37.72	
87402 OR 93120 -530	2X30	1.885/47.88	1.525/38.74	1.450/36.83	1.630/41.40	1.735/44.07	.125/3.18

mat'l. code		surface		tolerance		projection		product family	
-		ISO 1302 ✓		ISO 406 ISO 1101				RIBCAGE	
ltr	ecn	no	dr	date	tolerances unless otherwise specified		title		
P					angles	linear	INCH/MM		
					0.001x?	.xxx±.005/0.13	RIBCAGE HORIZONTAL HEADER ASSEMBLY		
						.xxxx±.0020/0.05	scale 3:1		
			dr	M. CORNMAN	6/6/95		dwg no		
			enr	D. WHITING	6/6/95		sheet 3 of 4		
			chr	D. WHITING	6/6/95		95780		
			appd	D. WHITING	6/6/95		size A3		
sheet index		revision sheet				type		Product Customer Drawing	



Copyright FCI

D

PRODUCT NUMBER
SEE TABLE

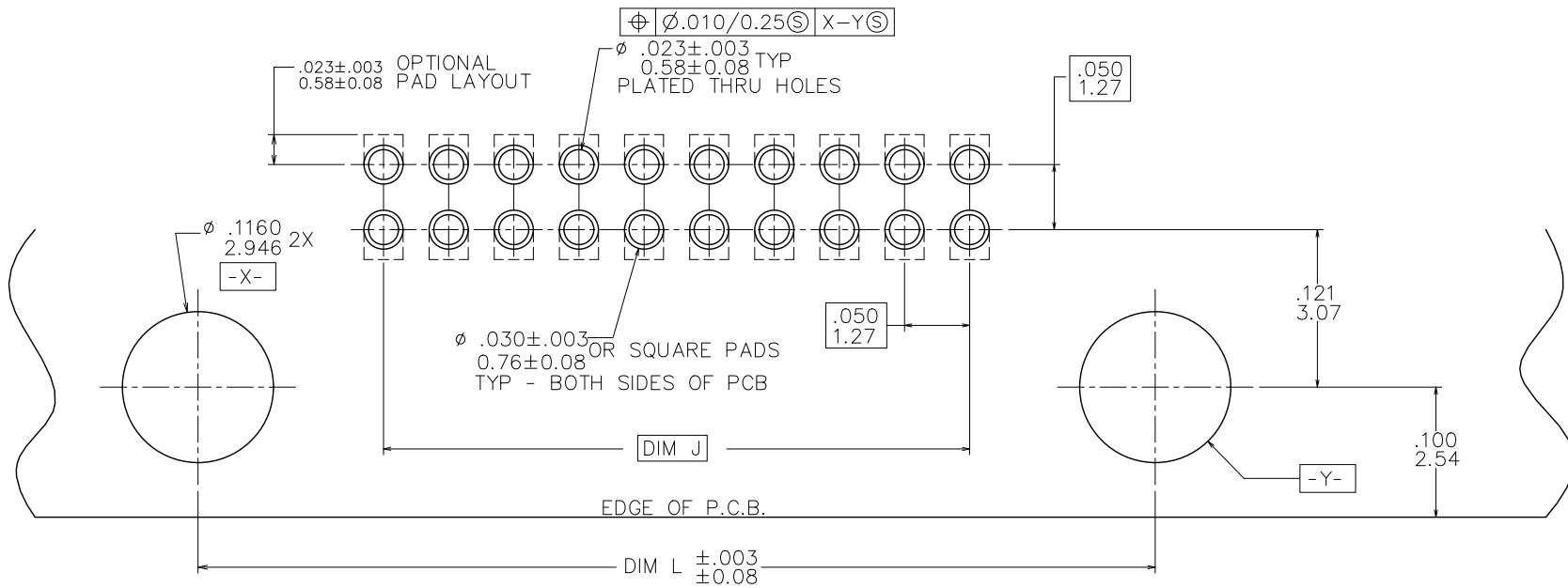

RECOMMENDED P.C.B. LAYOUT
SCALE 20/1

NOTES:

1. HOUSING MATERIAL:
GLASS FILLED THERMOPLASTIC FLAME RETARDANT PER UL 94V-0.
COLOR: NATURAL.
2. TERMINAL PLATING:
30u"/.76u MIN HARD GOLD OR GXT OVER 50u"/1.27u Ni ON CONTACT ZONES.
200u"/5.08u MIN Sn OVER 50u"/1.27u Ni IN SOLDERING ZONES.
3. CORING IN CENTER TO BE PRESENT ON PARTS THAT ARE 2X40 OR LARGER.
4. SUGGESTED FASTENERS:
#2 HI-LO THREAD 1/4" PANHEAD.
FASTECH INC.
(516) 242-5699

OR;
#1 CAPHEAD SCREW (3/8" LONG) AND NUT FOR (.062/1.57 BOARD).
5. 87402 AND 93120 ARE THE SAME. PLEASE ORDER AS 87402.
6. ADD "LF" SUFFIX AT THE END OF PART NUMBER FOR LEAD FREE OPTION.
7. THIS PRODUCT MEETS EUROPEAN UNION DIRECTIVES AND OTHER COUNTRY REGULATION AS DESCRIBED IN GS-22-008.
8. THE HOUSING WILL WITHSTAND EXPOSURE TO 260°C PEAK TEMPERATURE FOR 15 SECONDS IN A WAVE SOLDER APPLICATION WITH A 1.5mm MINIMUM THICK CIRCUIT BOARD. SEE APPLICATION NOTES/PROCEDURES IF THEY ARE AVAILABLE.
9. MOLDING FLOW RESTRICTOR QUANTITY AND LOCATION IS MANUFACTURING OPTION.
10. VACUUM CAP SLOT REQUIRED ON ALL SIZES, SLOT MAY BE LOCATED ON OPPOSITE SIDE FOR 2 X 5.
11. PRODUCT SPEC PER BUS-12-087.

mat'l. code		surface		tolerance		projection		product family		
-		ISO 1302 ✓		ISO 406 ISO 1101				RIBCAGE		
ltr	ecn	no	dr	date	tolerances unless otherwise specified		title			
P					angles	linear	INCH/MM			
					0.001x?	.XX±.01/0.3 .XXX±.005/0.13 .XXXX±.0020/0.05	RIBCAGE HORIZONTAL HEADER ASSEMBLY			
					dr	M. CORNMAN	6/6/95	dwg no sheet 4 of 4 size		
					engr	D. WHITING	6/6/95	95780 A3		
					chr	D. WHITING	6/6/95	type Product Customer Drawing		
					appd	D. WHITING	6/6/95			
sheet	revision									
index	sheet									