

REVISIONS					
P	LTR	DESCRIPTION	DATE	DWN	APVD
	N1	REVISED PER ECN-22-183424	14NOV2022	PT	SZ

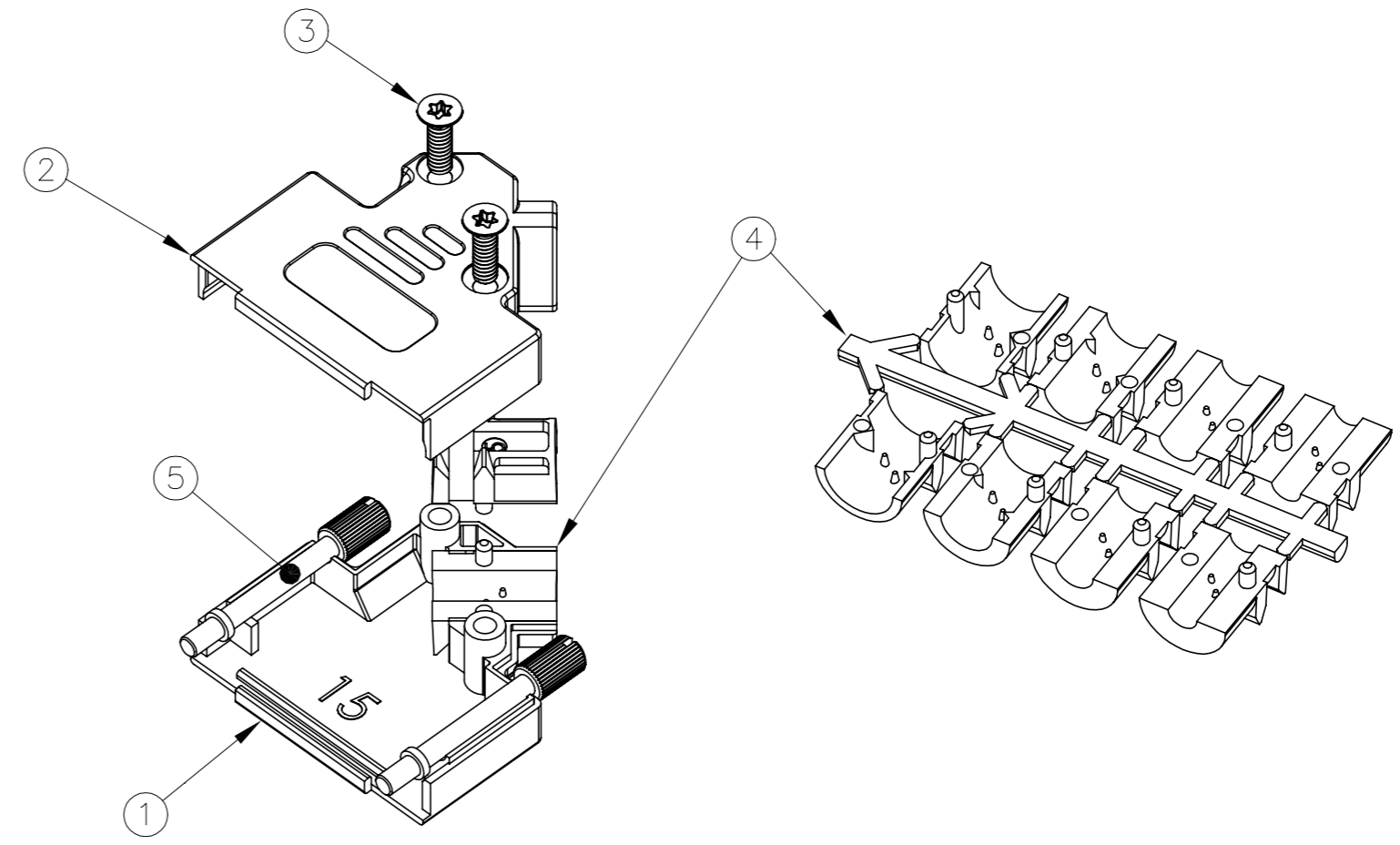
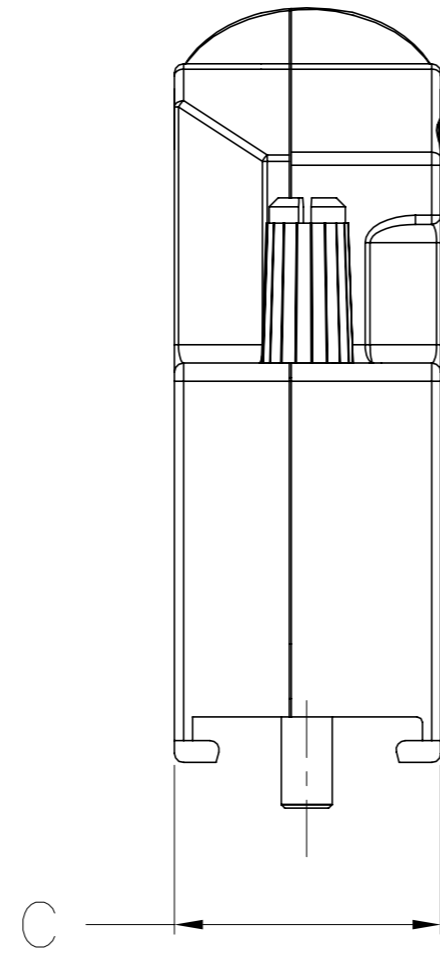
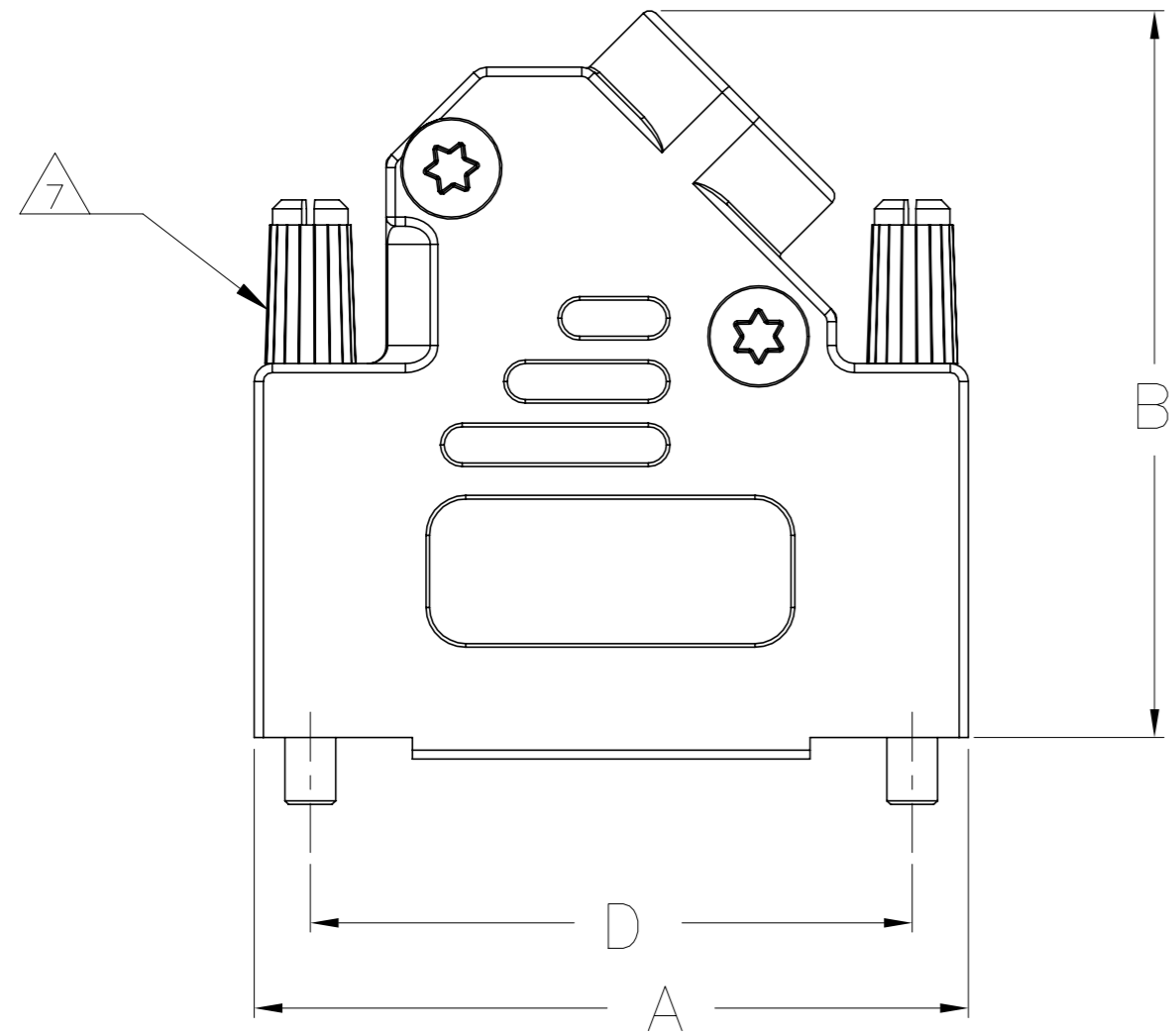

1. FOR ASSEMBLY DETAILS, REFER TO LEAFLET 2227518-1.

7 JACKSCREW QUANTITY:
 9 WAY ASSEMBLY: 1 JACKSCREW
 15 WAY ASSEMBLY: 2 JACKSCREWS
 25 WAY ASSEMBLY: 2 JACKSCREWS
 37 WAY ASSEMBLY: 2 JACKSCREWS

2 BULK PACKAGED BACKSHELL ASSEMBLIES:
 ITEM 1, 100 PCS LOOSE IN BOX. ITEMS 2 THRU 5, 100 TIMES QTY SHOWN IN TABLE IN 1 BAG FOR EACH ITEM. ALL BAGS IN 1 BOX WITH (1) 2227518-1 LEAFLET.

8. OPTIONAL CABLE CRIMP KIT AVAILABLE FOR 6.0-9.5 DIAMETER CABLE. SEE 1478764

3 INDIVIDUALLY PACKAGED SHELL ASSEMBLIES:
 1 BAG CONTAINS ALL COMPONENTS FOR 1 COMPLETE ASSEMBLY. 100 BAGS PER BOX, (1) 2227518-1 LEAFLET PER BOX.

4. TERMINATES 4.0-13.0 CABLE DIAMETERS.

5. 15 POSITION SHOWN.

6 TRIVALENT CHROMIUM CHROMATE COATING OVER ZINC PLATING.

3	63.5	14.6	40.2	69.7	TORX	4-40 UNC	4	37 WAY	5-1478763-4
3	47.0	14.6	40.2	53.2	TORX	4-40 UNC	3	25 WAY	5-1478763-3
3	33.3	14.6	40.2	39.5	TORX	4-40 UNC	2	15 WAY	5-1478763-2
3	25.0	14.6	36.2	31.0	TORX	4-40 UNC	1	9 WAY	5-1478763-1
2	47.0	14.6	40.2	53.2	TORX	M3	3	25 WAY	4-1478763-7
2	33.3	14.6	40.2	39.5	TORX	M3	2	15 WAY	4-1478763-6
2	25.0	14.6	36.2	31.0	TORX	M3	1	9 WAY	4-1478763-5
2	63.5	14.6	40.2	69.7	TORX	4-40 UNC	4	37 WAY	3-1478763-7
2	47.0	14.6	40.2	53.2	TORX	4-40 UNC	3	25 WAY	2-1478763-5
2	33.3	14.6	40.2	39.5	TORX	4-40 UNC	2	15 WAY	1-1478763-5
2	25.0	14.6	36.2	31.0	TORX	4-40 UNC	1	9 WAY	1478763-9
PACKAGING	D	C	B	A	SELF TAPPING FIXING SCREW TYPE	JACKSCREW THREAD	SHELL SIZE	POSITION	PART NUMBER

5	JACKSCREW ASSEMBLY	POLYAMIDE, UL94 V2 KNOB CARBON STEEL SHAFT	BLACK 6	7
4	STRAIN RELIEF SET	POLYCARBONATE UL94 V0	BLACK	1
3	SELF TAPPING FIXING SCREW	CARBON STEEL	6	2
2	TOP BACKSHELL	ZINC	NICKEL	1
1	BOTTOM BACKSHELL	ZINC	NICKEL	1
ITEM	DESCRIPTION	MATERIAL	FINISH	QTY

THIS DRAWING IS A CONTROLLED DOCUMENT. DIMENSIONING AND TOLERANCING PER ASME Y14.5M-2009

DIMENSIONS:	TOLERANCES UNLESS OTHERWISE SPECIFIED:
mm	0 PLC ± 0.5 1 PLC ± 0.5 2 PLC ± 0.5 3 PLC ± 0.5 4 PLC ± 0.5 ANGLES ± -
MATERIAL	FINISH
SEE TABLE	-

DWN	06JAN2011
C. VALENTINE	
CHK	06JAN2012
C. ROHDE	
APVD	06JAN2012
C. ROHDE	
PRODUCT SPEC	
APPLICATION SPEC	
WEIGHT	0.000000
CUSTOMER DRAWING	

TE TE Connectivity			
NAME ADK SERIES DIE-CAST BACKSHELL 45 DEGREE ENTRY			
SIZE	CAGE CODE	DRAWING NO	RESTRICTED TO
A2	00779	C=1478763	-
SCALE	SHEET	REV	
NTS	1 of 1	N1	