

REV.	DATE	ECR NO.	DESCRIPTION
NC	01/05/07	-	INITIAL RELEASE
A	06/07/07	-	REVISE BODY LENGTH AND DIAMETER, REVISE CONTACT PIN
B	01/28/08	-	ADD CABLE STRIPPING DIMENSIONS
C	05/25/08	100019	REVISE BODY AND CONTACT PIN DESIGN
D	07/21/08	-	ADD MID BODY DIA. DIMENSION 7.78 [.307]

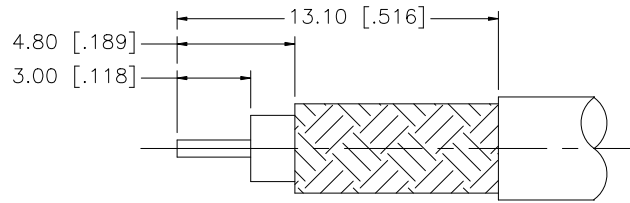

RECOMMENDED CABLE STRIPPING DIMENSIONS

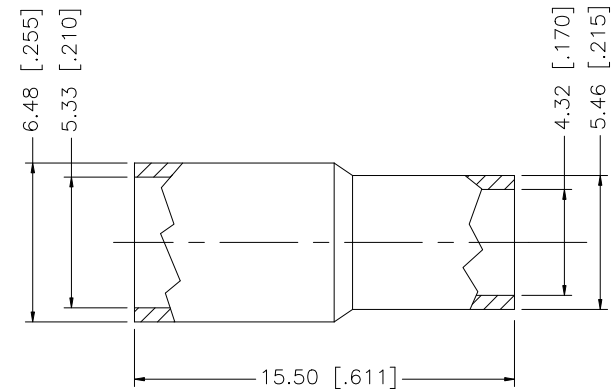
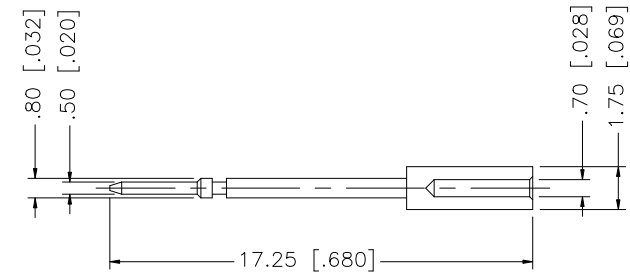
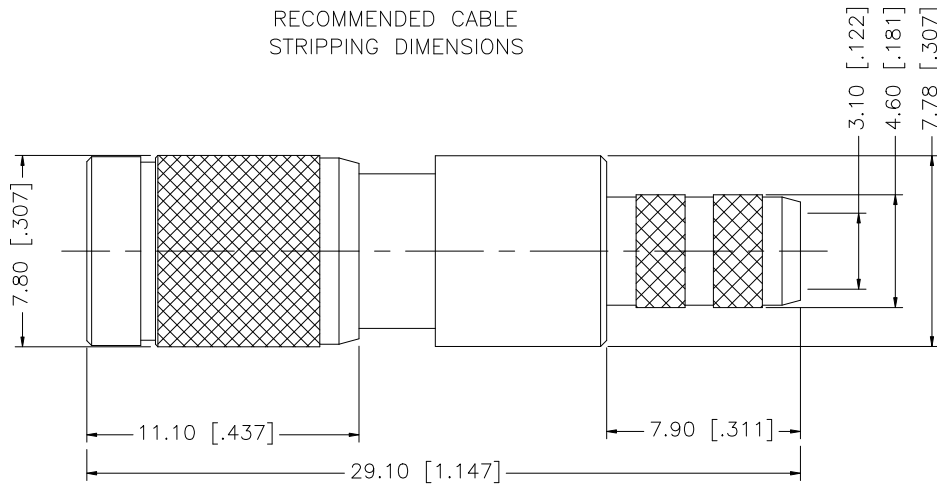

NOTE:

1. CRIMPED FERRULE HEX CRIMP SIZE .213"
2. CONTACT PIN TO SOLDER.

DESCRIPTION	MATERIAL	FINISH	QTY
FERRULE	COPPER	GOLD	1
CONTACT PIN	BRASS	GOLD	1
INSULATOR	PTFE	NATURAL	1
BODY	BRASS	NICKEL	1

UNLESS OTHERWISE SPECIFIED DIMENSIONS ARE IN MILLIMETERS. DIMENSIONS IN [] ARE IN INCHES AND FOR CUSTOMER REFERENCE ONLY.

UNLESS OTHERWISE SPECIFIED TOLERANCES FOR MILLIMETERS ARE:
0.5 - 8mm ± 0.20mm
8 - 30mm ± 0.40mm
30 - 120mm ± 0.50mm

UNLESS OTHERWISE SPECIFIED TOLERANCES FOR INCHES ARE:
.020 - .315 = ± 0.007"
.315 - 1.180 = ± 0.015"
1.180 - 4.724 = ± 0.020"

DO NOT SCALE DRAWING

APPROVALS	DATE
DRAWN G.R.S.	07/21/08
CHECKED	
ISSUED	
SHEET 1 OF 1	
CAD FILE	C:/282/282122-75.DWG

Amphenol Connex

PART DESCRIPTION			
1.0/2.3 PUSH-PULL CRIMP PLUG (FOR BELDEN 1855A CABLE)			
PART NO.		282122-75	
DWG. NO.	282122-75.DWG	REV.	D
SIZE	A	SCALE	NA