

## Description

The ZXBM5210 is a single chip solution for driving a single-coil reversible direct current (DC) fans and motors. The integrated full-bridge driver output stage is designed to minimize audible switching noise and electromagnetic interference (EMI) providing a low noise solution.

For system flexibility, the device has four modes of operation: Forward, Reverse, Brake and Standby selected via FWD and REV pins. The Forward and Reverse modes provide the motor rotation direction control, the Brake mode allows quick stop and the Standby mode helps system efficiency by powering down most of the internal circuits to consume less than 32µA typical. The motor speed can be adjusted by changing the duty ratio of the PWM signal on the FWD or REV pins in the PWM mode or alternatively by adjusting DC voltage input signal to the V<sub>REF</sub> pin in the VREF speed control mode.

To help protect the IC and the motor coil the ZXBM5210 includes under voltage, over voltage, over current and over temperature protections. Once the safe operating range has been exceeded the device shuts down the output drive to help prevent over stress on the IC or the coil. The device internal current protection threshold is 1.5A typical.

The ZXBM5210 is available in the standard SO8 and thermally enhanced SO8-EP packages.

## Features

- Supports single-coil reversible DC motor applications
- Operating voltage: 3V to 18V
- Four modes of operations: Forward, Reverse, Brake and Standby
- Low quiescent current of 0.85mA typical in normal operation and 32µA in standby mode
- Internal over current protection
- Under voltage lockout and over voltage protection
- Over temperature protection
- -40°C to +85°C / 105°C operating temperature
- 6kV ESD withstand capability
- Standard SO-8 and thermally enhanced SO-8EP
- **Totally Lead-Free & Fully RoHS Compliant (Notes 1 & 2)**
- **Halogen and Antimony Free. "Green" Device (Note 3)**

- Notes:
1. No purposely added lead. Fully EU Directive 2002/95/EC (RoHS) & 2011/65/EU (RoHS 2) compliant.
  2. See [http://www.diodes.com/quality/lead\\_free.html](http://www.diodes.com/quality/lead_free.html) for more information about Diodes Incorporated's definitions of Halogen- and Antimony-free, "Green" and Lead-free.
  3. Halogen- and Antimony-free "Green" products are defined as those which contain <900ppm bromine, <900ppm chlorine (<1500ppm total Br + Cl) and <1000ppm antimony compounds.

## Pin Assignments

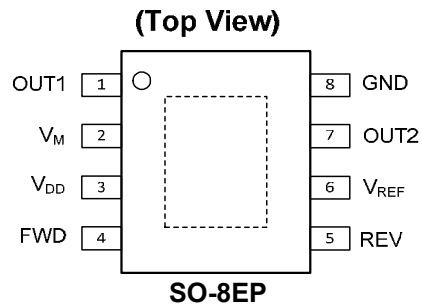
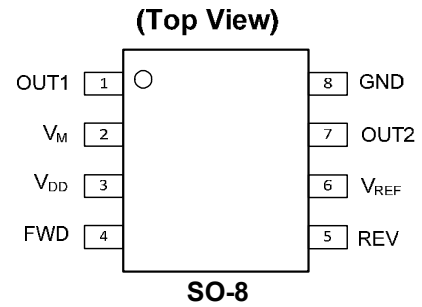

## Applications

- 5V / 9V / 12V / 15V DC reversible motors and actuators
- Home appliances
- Handheld power tools
- Valve open and close
- Remote control motorized toys
- Medium Voltage/ Low Power DC Motors

**Typical Applications Circuit**

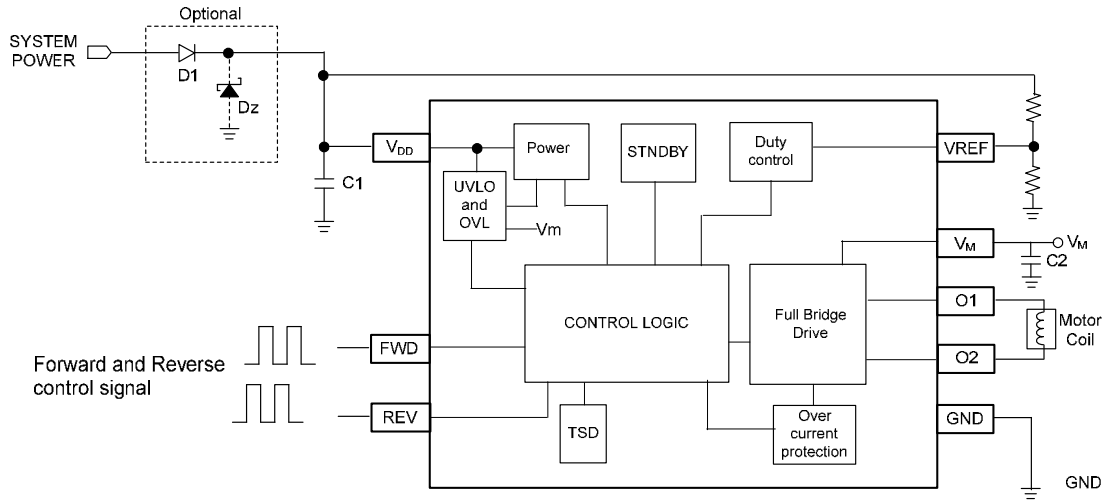

Note: 4. C1 is for power stabilization and to strengthen the noise immunity, the recommended capacitance is 100nF to 1µF or more.  
C2 is a re-circulating capacitor for back rush voltage and recommended capacitance is 100nF for low current applications to 10µF or more for large current applications. See application note section

**Pin Descriptions**

Package: SO-8

Pin #	Pin Name	Function
1	OUT1	Driver output
2	VM	Power Supply Voltage
3	VDD	Power Supply Voltage
4	FWD	Forward Control Input (logic level, 5.5V max)
5	REV	Reverse Control Input (logic level, 5.5V max)
6	VREF	Input reference voltage to set the internal PWM oscillator duty ratio
7	OUT2	Driver Output
8	GND	Ground

Package: SO8-EP

Pin #	Pin Name	Function
1	OUT1	Driver output
2	VM	Power Supply Voltage
3	VDD	Power Supply Voltage
4	FWD	Forward Control Input (logic level, 5.5V max)
5	REV	Reverse Control Input (logic level, 5.5V max)
6	VREF	Input reference voltage to set the internal PWM oscillator duty ratio
7	OUT2	Driver Output
8	GND	Ground
Pad	Pad	The exposed pad is for thermal dissipation and it is internally connected to the ground. On the PCB layout, it can be connected to GND or left open circuit.

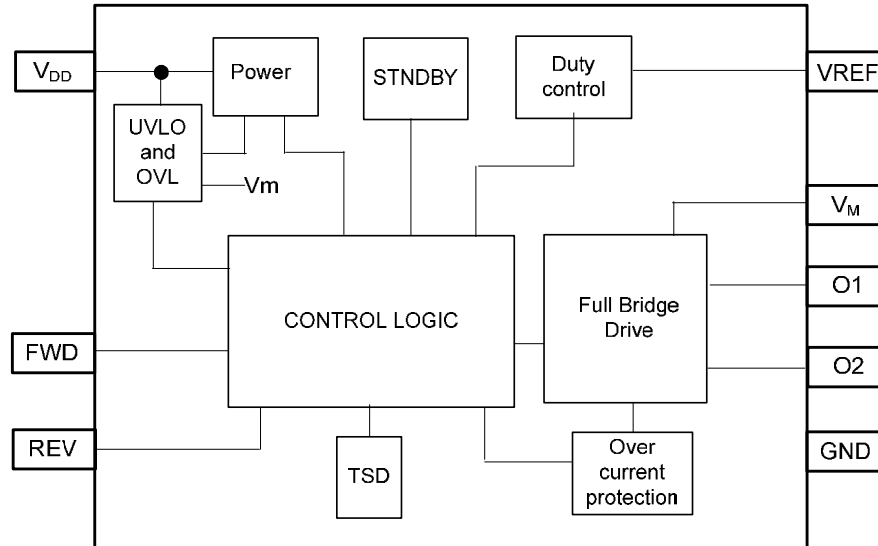
**Functional Block Diagram**

**Absolute Maximum Ratings** (Note 5) @ $T_A = +25^\circ\text{C}$ , unless otherwise specified.

Symbol	Characteristic	Values	Unit	
$V_M$ and $V_{DD}$	Supply voltage (Note 6)	24	V	
$V_{OUT1}$ , $V_{OUT2}$ $V_{REF}$	All other pins except FWD and REV pins	24	V	
$V_{FWD}$ and $V_{REV}$	FWD and REV pin voltage	7	V	
$V_{REVERSE}$	Reverse supply Voltage on all pins	-0.3	V	
$I_{OUTPUT}$	Output current (source and sink)- Peak	1500	mA	
$P_D$	Package power dissipation	SO8 (Note 7)	1043	mW
		SO8-EP (Note 8)	2980	mW
$T_s$	Storage temperature range	-65 to +150	$^\circ\text{C}$	
$T_J$	Maximum junction temperature	150	$^\circ\text{C}$	
ESD HBM	Human Body Model ESD withstand capability	$V_{DD}$ , $V_M$ , $V_{REF}$ , FWD, REV, GND and OUT1 OUT2 pins	6	kV

- Notes:
- Stresses greater than the 'Absolute Maximum Ratings' specified above, may cause permanent damage to the device. These are stress ratings only; functional operation of the device at these or any other conditions exceeding those indicated in this specification is not implied. Device reliability may be affected by exposure to absolute maximum rating conditions for extended periods of time
  - The absolute maximum supply voltage of 24V is a transient stress rating and is not meant as a functional operating condition. It is not recommended to operate the device at the absolute maximum rated conditions for any period of time.
  - SO-8 soldered to minimum recommended landing pads (see Package Outline Dimension section) on a 1"x1" two-layer 2oz.copper FR4 PCB (1.6mm thickness) without any via or copper flood on the bottom layer. See thermal de-rating curves in the thermal performance section.
  - SO-8EP exposed pad soldered to minimum recommended landing pads (see Package Outline Dimension section) on a 2"x2" two-layer 2oz.copper FR4 PCB (1.6mm thickness) with four thermal vias in the exposed PAD to the copper flood on the bottom layer. See thermal de-rating curves in the thermal performance section.

**Recommended Operating Conditions**

Symbol	Characteristic	Conditions	Min	Max	Unit
$V_{DD}$	Supply Voltage	Operating	3	18	V
$T_A$	Operating Temperature Range	Operating, SO8 package	-40	+85	$^\circ\text{C}$
		Operating, SO8-EP package	-40	+105	$^\circ\text{C}$

**Electrical Characteristics** (Note 9)(@ $T_A = +25^\circ\text{C}$ ,  $V_{DD} = 12\text{V}$ , unless otherwise specified.)

Symbol	Characteristics	Conditions	Min	Typ	Max	Unit
$I_{DD}$	Supply Current	No Load	—	0.85	2.5	mA
$I_{DD\_STNDBY}$	Standby Supply Current	FWD=REV=LOW (GND)	—	32	45	$\mu\text{A}$
$V_{UV\_TH}$	Under Voltage lock Out Threshold	Voltage Decreasing	—	2.6	—	V
$V_{UVLO\_R}$	Under Voltage Lock Out Release Threshold	Voltage Increasing	—	2.8	3.0	V
$V_{UV\_HYS}$	Under Voltage Hysteresis	Voltage Increasing	—	200	—	mV
$V_{OV\_TH}$	Overvoltage Threshold	Voltage Increasing	—	20.7	24	V
$V_{OV\_RLTH}$	Overvoltage Release Threshold	Voltage Decreasing	17.0	19	—	V
$V_{OH}$	Output Voltage High	$I_{OUT} = 300\text{mA}$ , $T_A = -40^\circ\text{C}$ to $+105^\circ\text{C}$	$V_{DD} - 0.25$	$V_{DD} - 0.15$	—	V
		$I_{OUT} = 500\text{mA}$ , $T_A = -40^\circ\text{C}$ to $+105^\circ\text{C}$	$V_{DD} - 0.43$	$V_{DD} - 0.25$	—	V
$V_{OL}$	Output Voltage Low	$I_{OUT} = 300\text{mA}$ , $T_A = -40^\circ\text{C}$ to $+105^\circ\text{C}$	—	0.15	0.25	V
		$I_{OUT} = 500\text{mA}$ , $T_A = -40^\circ\text{C}$ to $+105^\circ\text{C}$	—	0.25	0.43	V
$V_{OH} + V_{OL}$	Output voltage of N- and PMOS and bond wire voltage drop combined	$I_{OUT} = 300\text{mA}$ , $T_A = -40^\circ\text{C}$ to $+105^\circ\text{C}$	—	0.3	0.5	V
		$I_{OUT} = 500\text{mA}$ , $T_A = -40^\circ\text{C}$ to $+105^\circ\text{C}$	—	0.5	0.86	V
		$I_{OUT} = 300\text{mA}$ , $V_{DD} = 3\text{V}$ , $T_A = -40^\circ\text{C}$ to $+105^\circ\text{C}$	—	0.39	0.66	V
$R_{ON\_Total}$	Combined N- and PMOS $R_{DS(ON)}$ including bond wire resistance	$I_{OUT} = 500\text{mA}$ , $T_A = -40^\circ\text{C}$ to $+105^\circ\text{C}$	—	1	1.72	$\Omega$
		$I_{OUT} = 300\text{mA}$ , $V_{DD} = 3\text{V}$ , $T_A = -40^\circ\text{C}$ to $+105^\circ\text{C}$	—	1.3	2.2	$\Omega$
$I_{LIM\_TH}$	Over current protection threshold		1.2	1.5		A
$V_{REF}$	$V_{REF}$ voltage range (DC voltage speed control mode)		3	—	$V_{DD}$ (18V max)	V
$I_{VREF}$	$V_{REF}$ bias current (DC voltage speed control mode)	$V_{REF} = V_{DD}$	-15	0	15	$\mu\text{A}$
$F_{OUT}$	Output PWM switching frequency (Internal PWM oscillator)	$V_{REF}$ control mode	20	26.5	35	kHz
		PWM speed control mode	20	—	100	kHz
$F_{FWD\_REV}$	Input PWM frequency of speed control signal	PWM control mode	20	—	100	kHz
$T_{DEAD}$	Dead time between current reversal	$V_{DD} = 3\text{V}$ to $18\text{V}$ , $T_A = -40^\circ\text{C}$ to $+105^\circ\text{C}$	2.1	3	3.9	$\mu\text{s}$
$t_{SDN\_DELAY}$	Shutdown delay – Internal circuits active after FWD = REV = L (except from brake mode)	FWD = GND REV = GND	125	180	—	$\mu\text{s}$
$V_{FWDH}$	FWD Input H Level		2	—	5.5	V
$V_{FWDL}$	FWD Input L Level		0	—	0.8	V
$I_{FWDH}$	FWD pin current – H Level	FWD pin: $V_{FWD} = 5\text{V}$	—	50	—	$\mu\text{A}$
$I_{FWDL}$	FWD pin current – L Level	FWD pin: $V_{FWD} = 0\text{V}$	—	50	—	$\mu\text{A}$
$V_{REVH}$	REV Input H Level		2	—	5.5	V
$V_{REVL}$	REV Input L Level		0	—	0.8	V
$I_{REVH}$	REV pin current – H Level	REV pin: $V_{RVS} = 5\text{V}$	—	50	—	$\mu\text{A}$
$I_{REVL}$	REV pin current – L Level	REV pin: $V_{RVS} = 0\text{V}$	—	50	—	$\mu\text{A}$
$DPWM\_MIN$	Output minimum duty ratio		0%		100	%
$T_{J\_SDN\_TH}$	IC junction temperature thermal shutdown threshold		—	165	—	$^\circ\text{C}$
$T_{J\_SDN\_HYST}$	IC junction temperature thermal shutdown hysteresis		—	25	—	$^\circ\text{C}$

Note: 9. Typical data is at  $T_A = +25^\circ\text{C}$ ,  $V_{DD} = 12\text{V}$ . The maximum and minimum parameters values over the operating temperature range are not tested in production, they are guaranteed by design, characterization and process control.

## Application Note

### Rotation Control and Standby Modes

The device has FWD and REV pins for controlling the motor rotation directions. The device has four motor operation modes: 1) Standby mode, 2) Forward mode, 3) Reverse mode and 4) Brake mode. The four modes are controlled by the FWD and REV logic pins.

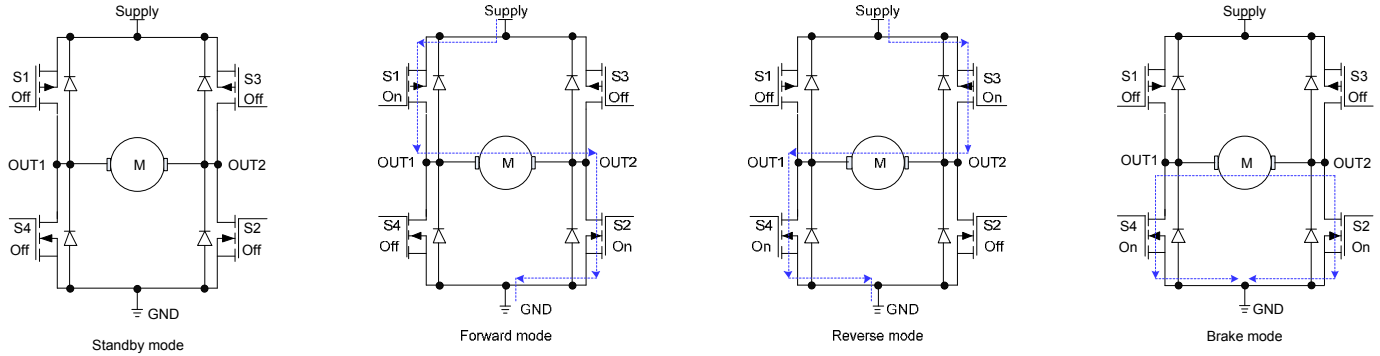

FWD	REV	V <sub>REF</sub>	OUT1	OUT2	Operating mode
L	L	x	Open	Open	Standby mode – All switches are off
H	L	3V to V <sub>DD</sub>	H	L	Forward mode – Current flows from OUT1 to OUT2; V <sub>REF</sub> duty control
L	H	3V to V <sub>DD</sub>	L	H	Reverse mode – Current flows from OUT2 to OUT1; V <sub>REF</sub> duty control
H	H	x	L	L	Brake mode – Short circuit brake with low side switches on
PWM	L	V <sub>DD</sub>	H	PWM	Forward mode – Current flows from OUT1 to OUT2; PWM control mode
L	PWM	V <sub>DD</sub>	PWM	H	Reverse mode – Current flows from OUT2 to OUT1; PWM control mode
H	H	x	L	L	Brake mode – Short circuit brake with low side switches on

In the brake mode, switches S2 and S4 are ON allowing the motor to stop quickly. All the internal control circuits are fully operational.

In the standby mode all the output drive switches are off and additionally, the internal circuits are also turned off to minimize power consumption. The power consumption in the standby mode is less than in the brake mode. If running motor enters the Standby mode, due to the body diodes the motor free wheels to idle state. Whenever the motor enters the standby mode from any mode (except the brake mode) the control logic will remain active in previous mode for at least 125µs before shutting down the internal circuits. To prevent device entering the standby mode during operating mode changes, the mode change signals should be completed within 125µs.

In the forward mode, with switches S1-S2 ON and S3-S4 OFF, OUT1 is high and OUT2 is low. The motor current flows from OUT1 to OUT2. In the reverse mode, switches S1-S4 are ON while S1-S2 are OFF to allow motor current flow from OUT2 to OUT1.

In the forward or reverse mode, for V<sub>REF</sub> speed control, the output drive duty ratio is generated internally based on the voltage on the V<sub>REF</sub> pin. For PWM speed control, external PWM signals applied to the FWD or REV pins control the PWM switching of the low side S2 (forward mode) or S4 (reverse mode). See application section for further details.

The ZXBM5210 has three modes of speed control: V<sub>REF</sub> speed control mode, PWM speed control mode and by adjusting the supply voltage

## Application Note (cont.)

### Motor Speed Control with DC Voltage on $V_{REF}$ Pin

Motor speed can be controlled by adjusting the DC voltage into the  $V_{REF}$  pin. The output drive PWM duty ratio is defined by the ratio of the  $V_{REF}$  voltage to the supply  $V_{DD}$  voltage.

In  $V_{REF}$  speed control mode, FWD and REV pins are only used for direction control and therefore high frequency PWM control signal should not be applied to the FWD and REV pins. If repetitive direction changes required, it is recommended to keep direction change frequency of below 400Hz.

The speed and direction control is given by:

FWD	REV	$V_{REF}$	OUT1	OUT2	Operating mode
L	L	x	Open	Open	Standby mode – All switches are off
H	L	$V_{DD}$	H	L	Forward mode – Current flows from OUT1 to OUT2; 100% duty
H	L	3V to $V_{DD}$	H	L	Forward mode – Current flows from OUT1 to OUT2; $V_{REF}$ duty control
L	H	$V_{DD}$	L	H	Reverse mode – Current flows from OUT2 to OUT1; 100% duty
L	H	3V to $V_{DD}$	L	H	Reverse mode – Current flows from OUT2 to OUT1; $V_{REF}$ duty control
H	H	x	L	L	Brake mode – Short circuit brake with low side switches on

### Motor Speed Control with a PWM Input Signal

Motor speed can be controlled by adjusting the duty cycle of the PWM speed control signal into the FWD or REV while keeping the  $V_{DD}$  pin at the nominal motor voltage. In this mode the input voltage on the  $V_{REF}$  pin must be greater than or equal to  $V_{DD}$ .

In PWM speed control mode the high side switches S1 and S3 are kept fixed while the low side switches S2 or S4 are switched. In the forward mode, S1 is kept switched on, S2 is switched in accordance with the PWM signal and S3 and S4 are switched off. In reverse mode, S3 is switched on, S4 is switched in accordance with the PWM signal and S1 and S2 are switched off.

The speed and direction control is given by:

FWD	REV	$V_{REF}$	OUT1	OUT2	Operating mode
L	L	x	Open	Open	Standby mode – All switches are off
H	L	$V_{DD}$	H	L	Forward mode – Current flows from OUT1 to OUT2; 100% duty
L	H	$V_{DD}$	L	H	Reverse mode – Current flows from OUT2 to OUT1; 100% duty
H	H	x	L	L	Brake mode – Short circuit brake with low side switches on
PWM	L	$V_{DD}$	H	$\overline{\text{PWM}}$	Forward mode – Current flows from OUT1 to OUT2; PWM control mode
L	PWM	$V_{DD}$	$\overline{\text{PWM}}$	H	Reverse mode – Current flows from OUT2 to OUT1; PWM control mode
H	H	x	L	L	Brake mode – Short circuit brake with low side switches on

The motor speed is proportional to the input PWM signal duty. For example, for a 12V motor the  $V_{DD}$  pin is maintained at 12V while varying the PWM control signal duty to adjust the motor speed linearly. The timing diagram below shows the output O1 and O2 in relation to PWM speed control signal at PWM pin.

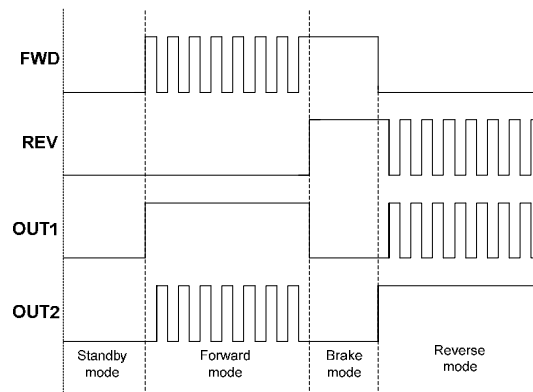

Frequency of PWM speed control signal can be between 8kHz to 100kHz. Recommended typical PWM signal frequency is 25kHz to keep switching frequency away from the audible band.

## Application Note (cont.)

### Motor Speed Control with a PWM Input Signal (cont.)

Depending on the motor design and its inertia the minimum start-up PWM duty required can be typically between 30% - 50%. While the motor is rotating minimum PWM duty can generally be reduced down to 20%. How small the PWM duty can be without stalling the motor depends on the motor mechanical and coil design parameters and not limited by the output capability of the device. If voltage at  $V_{DD}$  is lower than the nominal motor voltage, both start-up PWM duty and minimum running PWM duty required will be higher.

### Motor Speed Control by DC Supply Voltage

Motor speed can be controlled by varying the  $V_{DD}$  supply voltage while the FWD and REV pins are set to either a logic high or low depending on forward or reverse direction needed. The  $V_{REF}$  must be equal to  $V_{DD}$  in this mode. For example, if the  $V_{DD}$  for a 12V motor is changed from 12V to 3V the speed will be reduced from 100% to 25%.

### Re-Circulating Capacitor

During motor operation when the low side switch is turned off the bridge or the motor voltage may overshoot to high levels if there is no current path for the energy in the motor to flow. Such high voltages can damage the IC. A current path can be provided by adding a bypass capacitor from the  $V_{DD}$  or  $V_M$  to the GND. The value of the bypass capacitor depends on the motor coil design, motor current, motor voltage and the IC voltage limits. This could be in the range of 0.47 $\mu$ F for low current applications to 10 $\mu$ F or more for large current applications.

### Dead-Time

During motor current reversal (for motor rotation direction reversal), switch position changes between S1-S2 and S3-S4. Such change may result in cross conduction between high side and low side MOSFETS, e.g. S1 and S4 or S2 and S3. To prevent cross conduction the IC provides a dead time 3 $\mu$ s typical during current reversal or fast turn on of the low side MOSFETS.

### Back-Rush Voltage

Depending on motor characteristics, the environment and the ambient conditions back-rush voltage (at the bridge) may fluctuate during brush commutation and PWM switching. Due to the energy in the coil this back-rush voltage can reach high levels if no adequate alternative current path is provided when inductor current path is interrupted. The back-rush voltage overshoot should not be allowed to go beyond the operating voltage range of the IC. This backrush voltage overshoot can be minimized by using a re-circulating bypass capacitor at the  $V_{DD}$  and  $V_M$  pins.

The value of the re-circulating bypass capacitor depends on the motor coil design, motor current, motor voltage and the IC voltage limits. This could be 0.47 $\mu$ F for low current applications to 10 $\mu$ F or more for large current applications.

### Under Voltage Lockout

To make sure the minimum voltage needed to operate the driver is supplied, the driver has an under voltage lock out. At start up the device will only start if the supply voltage is typically 2.8 or greater. During normal operation, the device will switch off all the output switches and power down if the supply voltage drops below 2.6V typical.

### Over Voltage Protection

When the supply voltage exceeds 20.7V (typical) the driver will turn-off all the output switches. The driver will return to normal condition if the supply voltage drops below 19V (typical) provided no other fault condition or signals are preventing it to enter normal operation.

### In-Rush Current

It is recommended to use the PWM duty cycle to control the average voltage supplied to the motor during power up, standby mode, brake mode or during motor direction reversal. If a PWM signal is not available it is recommended to use a current limiting resistor or other protection devices if needed.

### Over-Current Setting and Protection

The internal over current protection (OCP) threshold is 1.5A typical at 12V supply +25°C.

When the motor current exceeds the OCP threshold for longer than 10 $\mu$ s typical on any of the H-Bridge switches, the device will switch off all the output switches and remain off for 5ms typical. The IC returns to normal operation after the 5ms if over current condition has gone away. If the motor current is still higher than the OCP threshold, the device will enter another 5ms standby mode.

### Thermal Shutdown

The device has an internal thermal shutdown to prevent a thermal run-away scenario. The thermal shutdown is triggered when the junction temperature of the device reaches +165°C. It will remain in standby mode until the junction temperature falls by +25°C.

### Reverse Voltage Protection

If reverse protection is needed this can be achieved by adding an external diode to the  $V_{DD}$  and  $V_M$  pins.

**Application Note** (cont.)

**Motor Electromagnetic and Audible Noise**

To help reduce electromagnetic and audible noise, capacitor can be connected from OUT1 to GND and OUT2 to GND pins. Alternatively, a capacitor can be connected between OUT1 and OUT2 with diodes between the output pins and GND as shown below. To prevent large currents it is recommended to keep any capacitor used at the output pins as small as possible and less than 1µF.

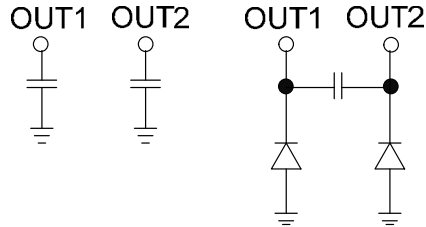



**Typical Operating Characteristics**

**Supply Current**

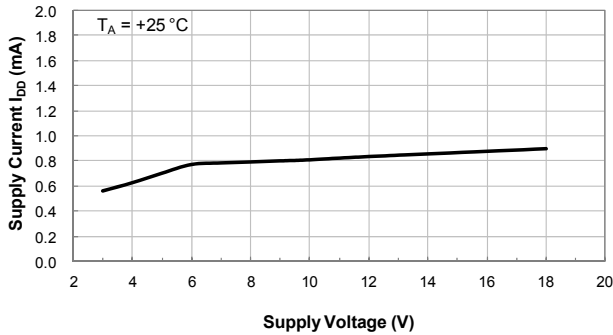

Supply Current vs. Supply Voltage

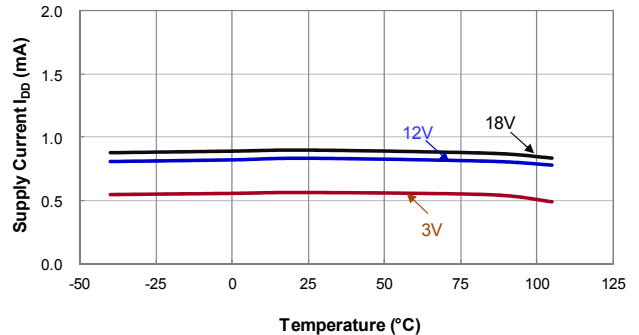

Supply Current vs. Temperature

**Standby Current**

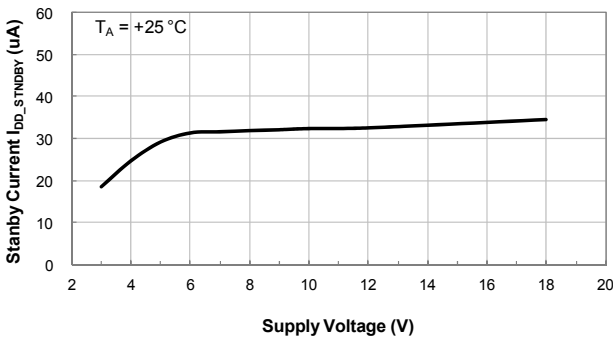

Standby Supply Current vs. Supply Voltage

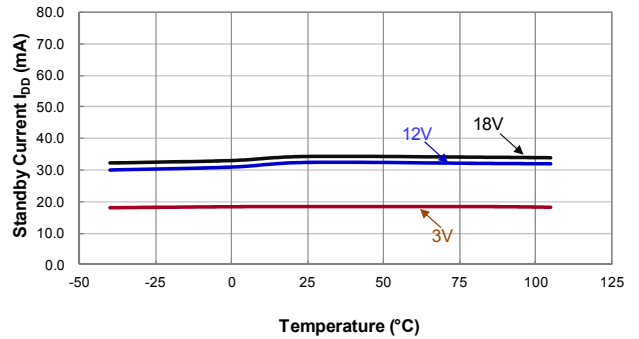

Standby Supply Current vs. Temperature

**Under Voltage Lockout (UVLO)**

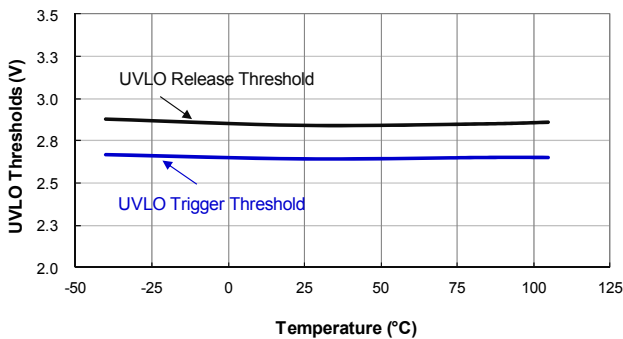

UVLO Trigger and Release Thresholds vs Temperature

**Over Voltage Protection (OVP)**

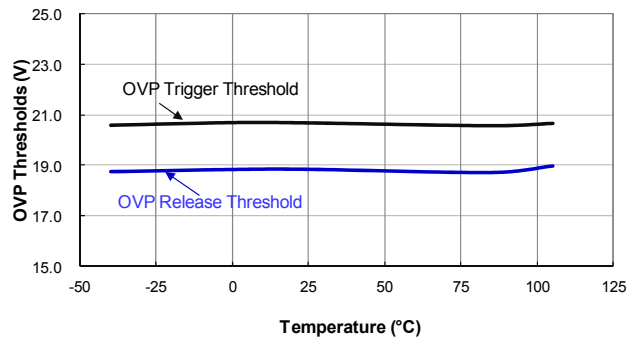

OVP Trigger and Release Thresholds vs Temperature

**Typical Operating Characteristics**

**Output PWM Duty in PWM Speed Control Mode**

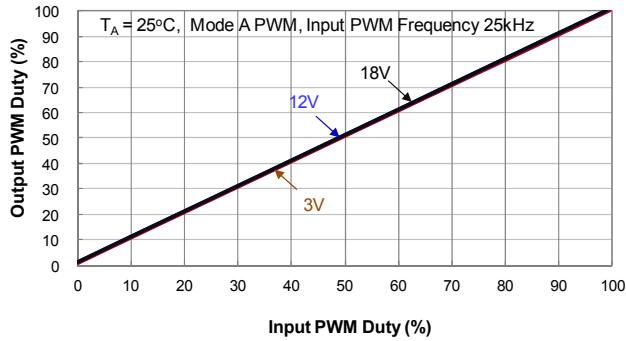

Output PWM Duty vs Input PWM Duty

**Output PWM Duty in VREF Speed Control Mode**

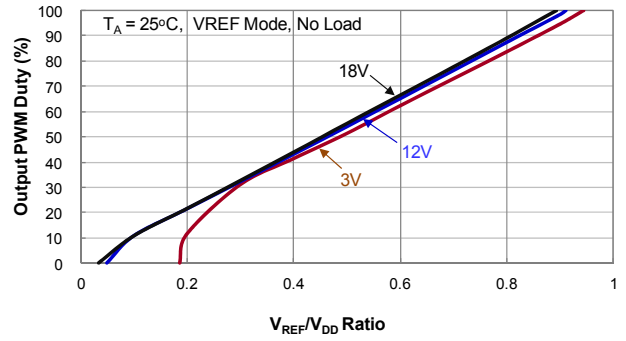

Output PWM Duty vs  $V_{REF}/V_{DD}$  Ratio

**PWM Oscillator Frequency**

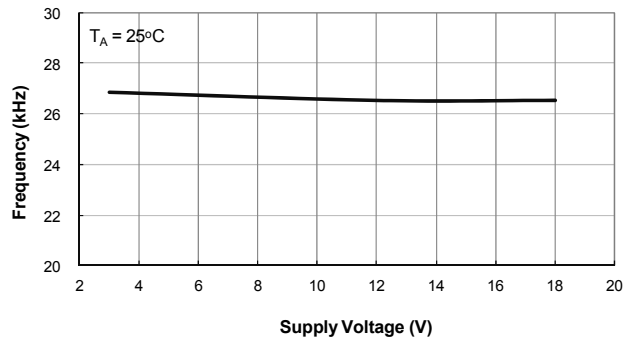

PWM Oscillator Frequency vs. Supply Voltage

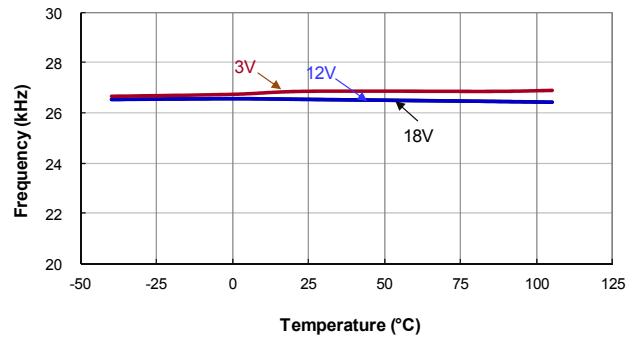

PWM Oscillator Frequency vs. Temperature

**Typical Operating Characteristics**

**Low Side Switch ON Voltage ( $V_{OL}$ )**

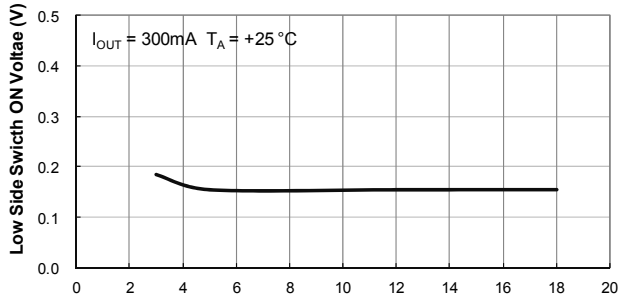

Low Side Switch ON Voltage  $V_{OL}$  vs. Supply Voltage

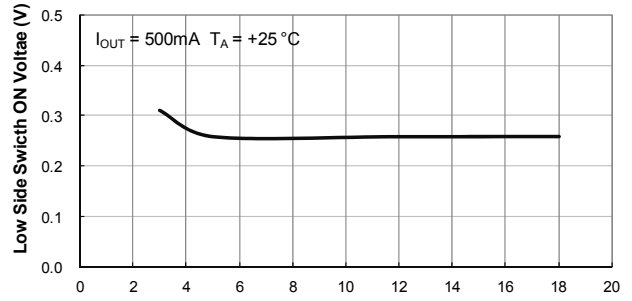

Low Side Switch ON Voltage  $V_{OL}$  vs. Supply Voltage

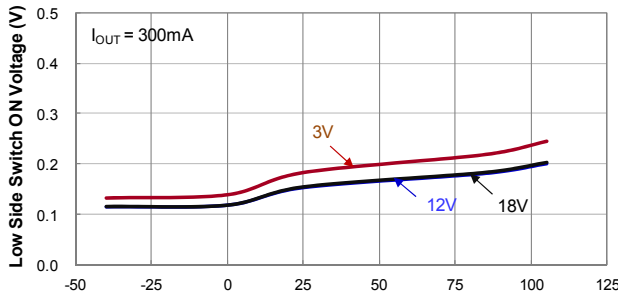

Low Side Switch ON Voltage  $V_{OL}$  vs. Temperature

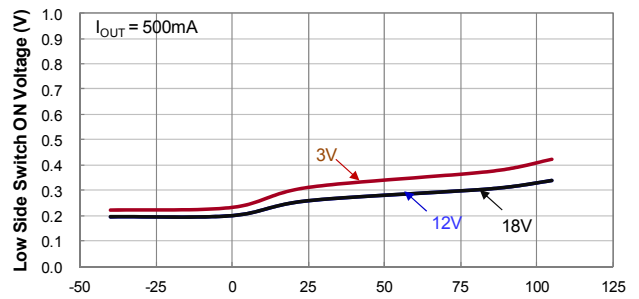

Low Side Switch ON Voltage  $V_{OL}$  vs. Temperature

**High Side Switch ON Voltage ( $V_{DD} - V_{OH}$ )**

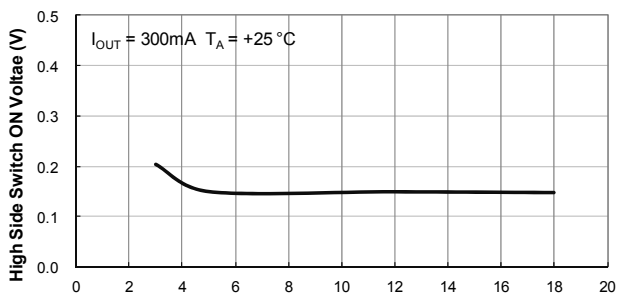

High Side Switch ON Voltage ( $V_{DD} - V_{OH}$ ) vs. Supply Voltage

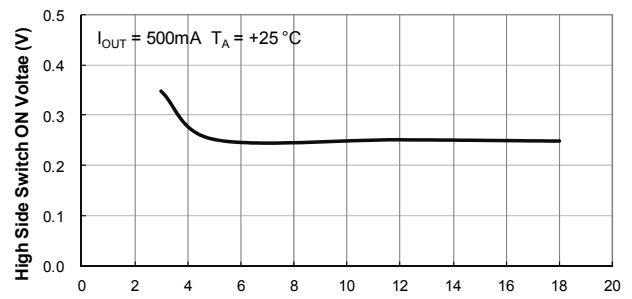

High Side Switch ON Voltage ( $V_{DD} - V_{OH}$ ) vs. Supply Voltage

**Typical Operating Characteristics**

**High Side Switch On Voltage ( $V_{DD} - V_{OH}$ ) (cont.)**

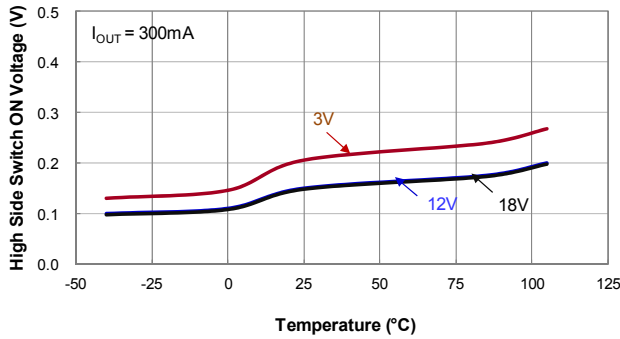

HighSide Switch On Voltage ( $V_{DD}-V_{OL}$ ) vs. Temperature

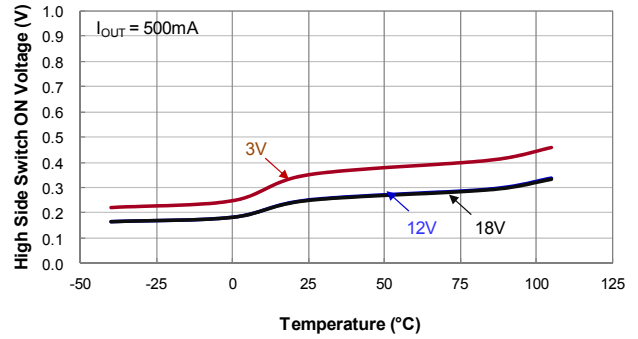

HighSide Switch On Voltage ( $V_{DD}-V_{OL}$ ) vs. Temperature

**H-Bridge Resistance – Total Resistance On ( $R_{DSON\_TOTAL}$ ) of the High and the Low Side Switches**

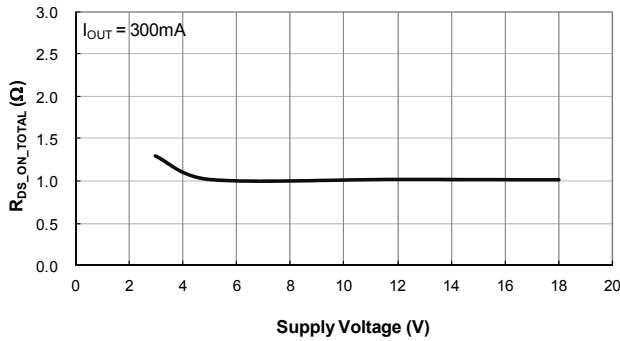

High+Low Side Resistance  $R_{DSON\_TOTAL}$  vs. Voltage

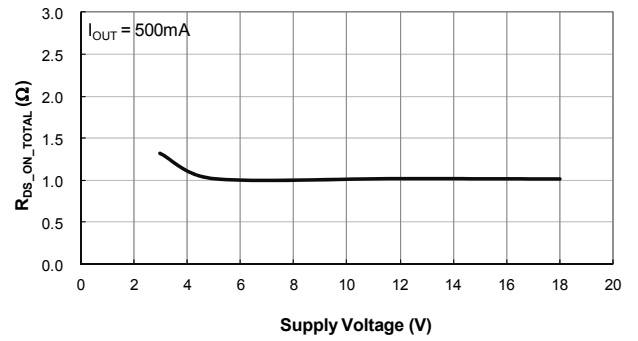

High+Low Side Resistance  $R_{DSON\_TOTAL}$  vs. Voltage

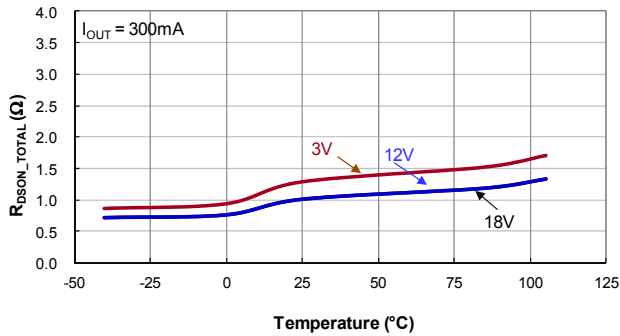

High+Low Side ON Resistance  $R_{DSON\_TOTAL}$  vs. Temperature

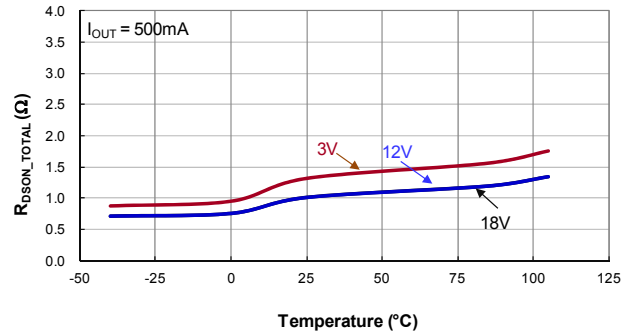

High+Low Side ON Resistance  $R_{DSON\_TOTAL}$  vs. Temperature

**Thermal Performance**

(1) Package Type: SO-8

**MSOP8-EP Power Dissipation De-rating Curve (Note 11)**

T <sub>A</sub> (°C)	-40	0	25	50	60	70	80	85	90	95	100	105	110	120	125	130	140	150
P <sub>D</sub> (mW)	1043	1043	1043	835	751	668	584	543	501	459	417	376	334	250	209	167	83	0

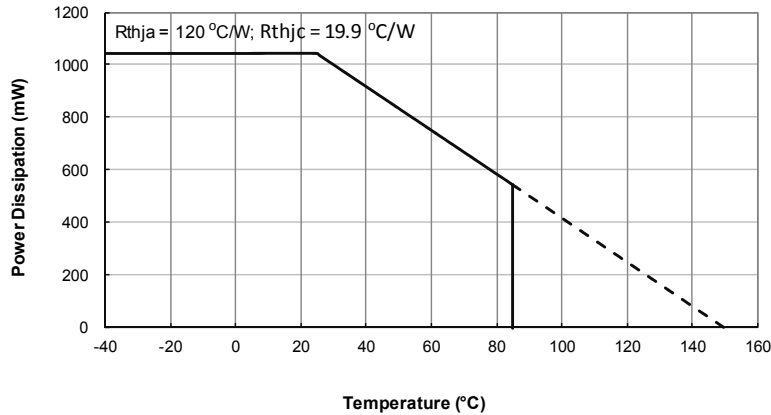

**SO-8 Thermal Derating Curve**

Note: 11. SO-8 soldered to minimum recommended landing pads (see Package Outline Dimension section) on a 1"x1" two-layer 2oz.copper FR4 PCB (1.6mm thickness) without any via or copper flood on the bottom layer.

(2) Package Type: SO-8EP

**SO-8EP Power Dissipation De-rating Curve (Note 12)**

T <sub>A</sub> (°C)	-40	0	25	50	60	70	80	85	90	95	100	105	110	120	125	130	140	150
P <sub>D</sub> (mW)	2980	29080	2980	2384	2146	1907	1669	1550	1430	1430	1192	1073	954	715	596	477	238	0

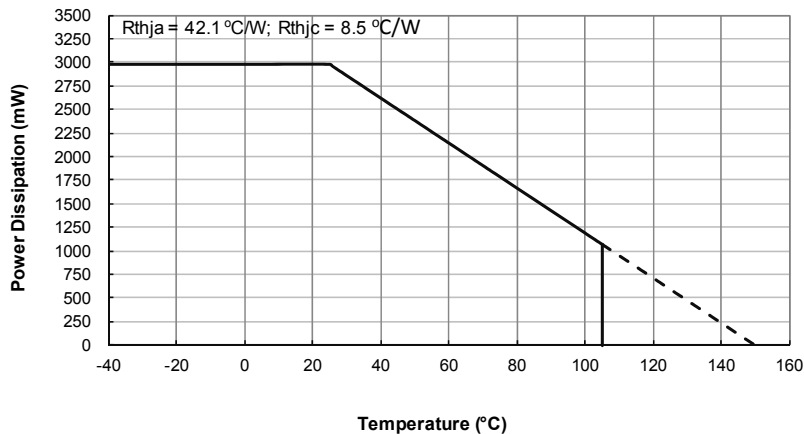

**SO-8EP Thermal Derating Curve**

Note: 12. SO-8EP exposed pad soldered to minimum recommended landing pads (see Package Outline Dimension section) on a 2"x2" two-layer 2oz.copper FR4 PCB (1.6mm thickness) with four thermal vias in the exposed PAD to the copper flood on the bottom layer

**Ordering Information**

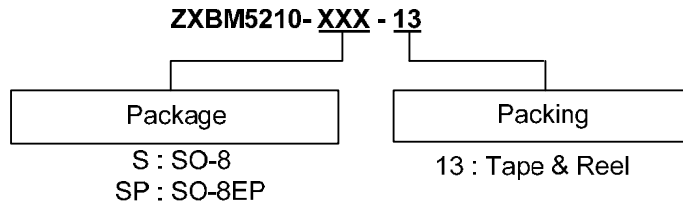

Part Number	Package Code	Packaging	13" Tape and Reel	
			Quantity	Part Number Suffix
ZXBM5210-S-13	S	SO-8	2500/Tape & Reel	-13
ZXBM5210-SP-13	SP	SO-8EP	2500/Tape & Reel	-13

**Marking Information**

(1) Package type: SO-8

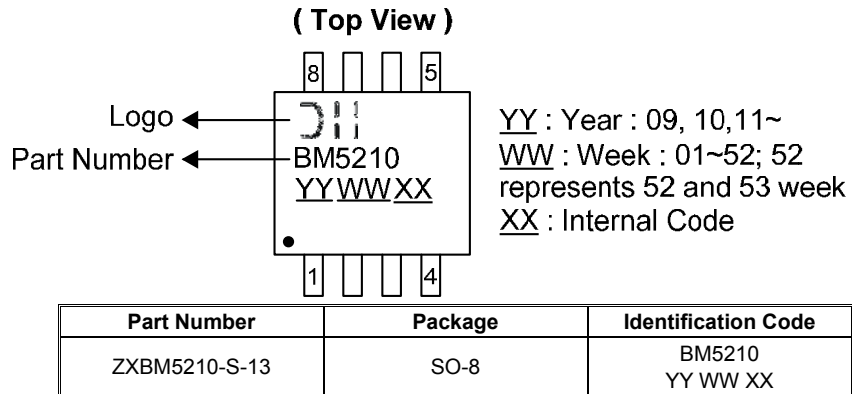

(2) Package type: SO-8EP

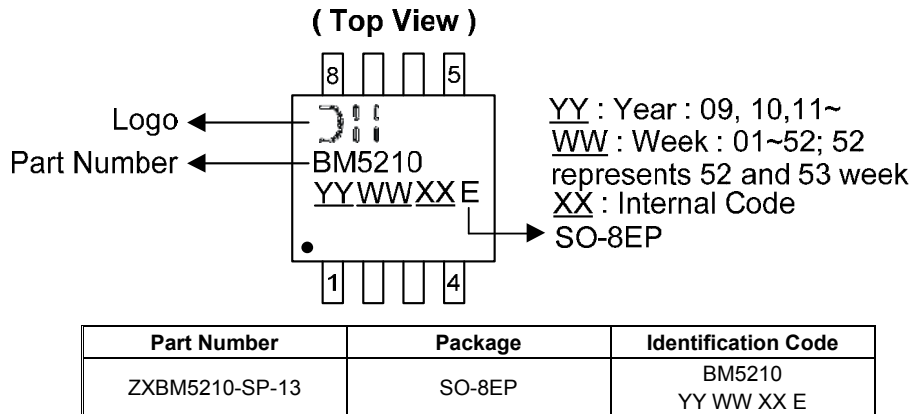

**Package Outline Dimensions** (All dimensions in mm.)

Please see AP02002 at <http://www.diodes.com/datasheets/ap02002.pdf> for latest version.

(1) Package Type: SO-8

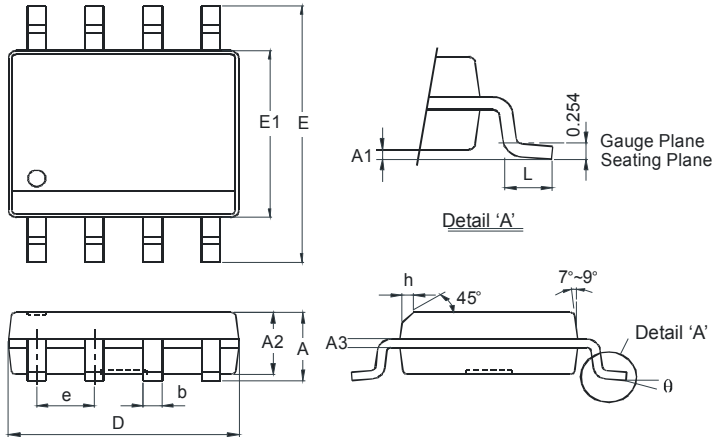

SO-8		
Dim	Min	Max
A	-	1.75
A1	0.10	0.20
A2	1.30	1.50
A3	0.15	0.25
b	0.3	0.5
D	4.85	4.95
E	5.90	6.10
E1	3.85	3.95
e	1.27 Typ	
h	-	0.35
L	0.62	0.82
θ	0°	8°
All Dimensions in mm		

(2) Package Type: SO-8EP

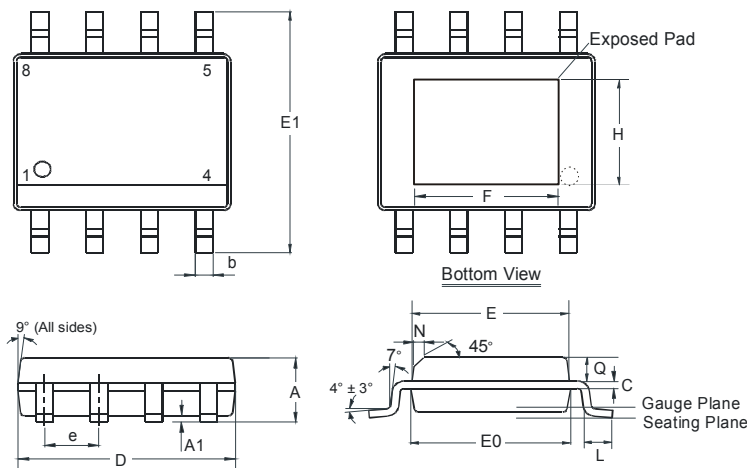

SO-8EP (SOP-8L-EP)			
Dim	Min	Max	Typ
A	1.40	1.50	1.45
A1	0.00	0.13	-
b	0.30	0.50	0.40
C	0.15	0.25	0.20
D	4.85	4.95	4.90
E	3.80	3.90	3.85
E0	3.85	3.95	3.90
E1	5.90	6.10	6.00
e	-	-	1.27
F	2.75	3.35	3.05
H	2.11	2.71	2.41
L	0.62	0.82	0.72
N	-	-	0.35
Q	0.60	0.70	0.65
All Dimensions in mm			

## Suggested Pad Layout

Please see AP02001 at <http://www.diodes.com/datasheets/ap02001.pdf> for the latest version.

### (1) Package Type: SO-8

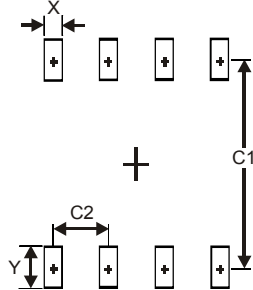

Dimensions	Value (in mm)
X	0.60
Y	1.55
C1	5.4
C2	1.27

### (2) Package Type: SO-8EP

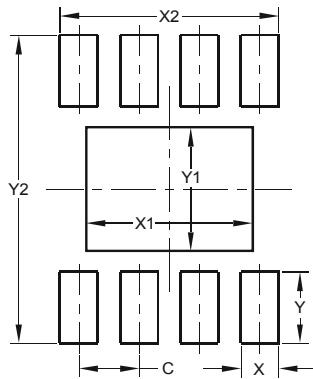

Dimensions	Value (in mm)
C	1.270
X	0.802
X1	3.502
X2	4.612
Y	1.505
Y1	2.613
Y2	6.500



**IMPORTANT NOTICE**

DIODES INCORPORATED MAKES NO WARRANTY OF ANY KIND, EXPRESS OR IMPLIED, WITH REGARDS TO THIS DOCUMENT, INCLUDING, BUT NOT LIMITED TO, THE IMPLIED WARRANTIES OF MERCHANTABILITY AND FITNESS FOR A PARTICULAR PURPOSE (AND THEIR EQUIVALENTS UNDER THE LAWS OF ANY JURISDICTION).

Diodes Incorporated and its subsidiaries reserve the right to make modifications, enhancements, improvements, corrections or other changes without further notice to this document and any product described herein. Diodes Incorporated does not assume any liability arising out of the application or use of this document or any product described herein; neither does Diodes Incorporated convey any license under its patent or trademark rights, nor the rights of others. Any Customer or user of this document or products described herein in such applications shall assume all risks of such use and will agree to hold Diodes Incorporated and all the companies whose products are represented on Diodes Incorporated website, harmless against all damages.

Diodes Incorporated does not warrant or accept any liability whatsoever in respect of any products purchased through unauthorized sales channel. Should Customers purchase or use Diodes Incorporated products for any unintended or unauthorized application, Customers shall indemnify and hold Diodes Incorporated and its representatives harmless against all claims, damages, expenses, and attorney fees arising out of, directly or indirectly, any claim of personal injury or death associated with such unintended or unauthorized application.

Products described herein may be covered by one or more United States, international or foreign patents pending. Product names and markings noted herein may also be covered by one or more United States, international or foreign trademarks.

This document is written in English but may be translated into multiple languages for reference. Only the English version of this document is the final and determinative format released by Diodes Incorporated.

**LIFE SUPPORT**

Diodes Incorporated products are specifically not authorized for use as critical components in life support devices or systems without the express written approval of the Chief Executive Officer of Diodes Incorporated. As used herein:

A. Life support devices or systems are devices or systems which:

1. are intended to implant into the body, or
2. support or sustain life and whose failure to perform when properly used in accordance with instructions for use provided in the labeling can be reasonably expected to result in significant injury to the user.

B. A critical component is any component in a life support device or system whose failure to perform can be reasonably expected to cause the failure of the life support device or to affect its safety or effectiveness.

Customers represent that they have all necessary expertise in the safety and regulatory ramifications of their life support devices or systems, and acknowledge and agree that they are solely responsible for all legal, regulatory and safety-related requirements concerning their products and any use of Diodes Incorporated products in such safety-critical, life support devices or systems, notwithstanding any devices- or systems-related information or support that may be provided by Diodes Incorporated. Further, Customers must fully indemnify Diodes Incorporated and its representatives against any damages arising out of the use of Diodes Incorporated products in such safety-critical, life support devices or systems.

Copyright © 2013, Diodes Incorporated

[www.diodes.com](http://www.diodes.com)