

REVISIONS					
REV	ECO	DESCRIPTION	DATE	BY	APPR
B1	-	RELEASED DRAWING	JAN-18-2014	ARROW	TOMMY
B2	-	ADDED MS24W23G5	JUL-28-2023	JUN	TOMMY
B3	-	ADDED MS24W23T,MS24W23S	AUG-2-2023	JUN	TOMMY

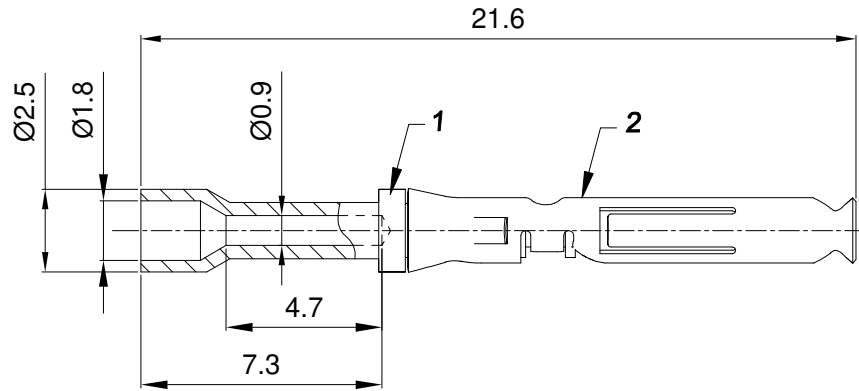

- NOTES: (UNLESS OTHERWISE SPECIFIED)
- MATERIAL:
 - CONTACT BODY: COPPER ALLOY.
 - POSITIONING CLIP: STAINLESS STEEL.
 - SPECIFICATIONS:
 - CURRENT RATING: 7.5A(MAX).
 - TERMINATION TYPE: CRIMPING.
 - CRIMP WIRE RANGE: 26~24AWG.
 - SUITABLE SOCKET TYPE: MP24W23xx.
 - ROHS COMPLIANT.
 - ALL DIMENSION ARE FOR REFERENCE USE ONLY.

P/N	CONTACT PLATING(MATING AREA)
MS24W23T	TIN PLATING OVER NICKEL.
MS24W23S	SILVER PLATING OVER NICKEL.
MS24W23F	GOLD FLASH PLATING OVER NICKEL.
MS24W23G5	5μ"GOLD PLATING OVER NICKEL.
MS24W23G10	10μ"GOLD PLATING OVER NICKEL.
MS24W23G15	15μ"GOLD PLATING OVER NICKEL.
MS24W23G30	30μ"GOLD PLATING OVER NICKEL.

QUANTITY	PART NUMBER	DESCRIPTION	ITEM
MATERIALS LIST			
UNLESS OTHERWISE SPECIFIED 1) All dimensions are in metric(mm). 2) Tolerances are as follows: 1 PL DEC ±0.30 2 PL DEC ±0.15 3 PL DEC ±0.08 Fractions ±1/64 Angles ±1° 3) Note reference =		SIGNATURES DATE DRAWN: JUN AUG-2-2023 CHECKED: JOE AUG-4-2023 ENGINEER: APPROVAL: TOMMY AUG-8-2023 CUSTOMER:	 Sine Systems - www.amphenol-sine.com 44724 Morley Drive Clinton Township, MI 48036
MATERIAL SPECIFICATIONS: PROCESS SPECIFICATIONS: NEXT ASSY:		THIS DRAWING IS SUPPLIED FOR INFORMATION ONLY. DESIGN FEATURES, SPECIFICATIONS AND PERFORMANCE DATA SHOWN HEREON ARE THE PROPERTY OF THE AMPHENOL CORPORATION. NO RIGHTS OF REPRODUCTION ARE IMPLIED. ALL DIMENSIONS ARE SUBJECT TO NORMAL MANUFACTURING VARIATIONS.	ECO-MATE, SOCKET CONTACT, MACHINE, 26-24AWG, SIZE 20 SIZE: B TYPE: C- DWG NO: MS24W23xx REVISION: B3 SCALE: NONE SHEET 1 OF 1

TITLE: ECO-MATE SOCKET CONTACT, MACHINE, 26-24AWG, SIZE 20
 DWG NO.: MS24W23xx
 REV: B3
 SH: 1
 OF: 1