

LC Sine Wave Filter for Motor Drives

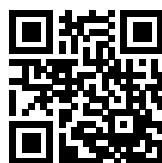

- Prevention of overvoltage on the motor
- Reduction of motor noise
- Reduction of motor losses
- Increase motor service life
- Possible to apply long motor cables



Approvals & Compliances

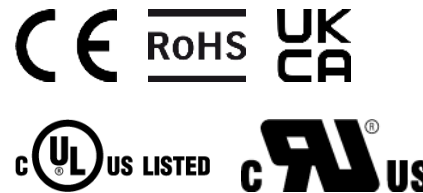

Depending on filter configuration. For use with AC or DC drives (power conversion equipment) only.

Features and Benefits

- Converts the rectangular PWM output voltage of motor drives into a smooth sine wave with low residual ripple
- Elimination of premature motor damage caused by high dv/dt, overvoltages, cable ringing and motor overheating
- Improves bearing life time because of bearing currents caused by circulating currents
- Complies with IEC 60034-17* requirements for general purpose motors
- Optional with IP20 protective cover

Typical Applications

- HVAC applications
- Pumps
- Conveyors
- Compressors
- Elevators
- Cranes
- Medium voltage applications, deployed in front of the step-up transformer
- Retrofit installations with motor drives
- Motor drive with long motor cable
- Motor drive with multiple motors in parallel

Technical Specifications

Nominal operating voltage	3x480 VAC
Rated operating voltage	3x530 VAC
Pollution degree	3
High potential test voltage	P → E 2480 VAC, 1 s
Protection category	IP00 (E0XXT versions) IP20 (E2FXT option, up to 110A version)
Overload capability	1.5x rated current for 1 minute, once per hour
Ambient temperature range	-40°C to +45°C fully operation +45°C to +100°C (up to 18A) or +70°C (26A and above) derated operation* -40°C to +70°C transport and storage
Design corresponding to	Filter: UL 61800-5-1, EN 61800-5-1 Chokes: EN 61558-2-20 or EN 60076-6
Motor frequency	0 to 60 Hz 0...60 Hz (up to 200Hz with derating, see user manual)
Climatic class	40/070/21
Switching frequency f _{PWM}	Min. 2 or 4kHz, max. 16kHz, see filter selection table
Impedance (uk)	6% @ 400 V, 50 Hz and rated current
Residual ripple voltage	<5%
Flammability corresponding to	UL-94V-0
Motor cable length	Up to 1'000 m or 2'000 m (see user manual)
Overvoltage category	III acc. IEC 60664-1
Rated currents	2.3 to 1000 A
Switching frequency	2 to 16 kHz

* Derated = $Inominal \cdot \sqrt{\frac{T_{max} - T_{amb}}{T_{max} - T_{nominal}}}$ - please refer to user manual for details and example

Typical electrical schematic

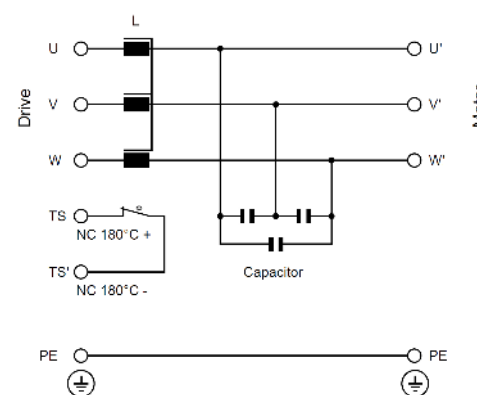

Filter Selection Table FN 5420 IP00

Filter	Rated current @ 45°C/ 50Hz [A]	Typical motor drive power rating @ 400 V* [kW]	Typical motor drive power rating @ 480 V** [kW]	Nominal inductance [mH]	Nominal capacitance*** [μF]	Min. switching frequency [kHz]	Typical power loss**** [W]	Input/ Output terminals	Weight [kg]
FN5420-2.3-88-E0XXT	2.3	0.75	0.90	19.2	3x0.47	4	41	88	1.20
FN5420-3.1-88-E0XXT	3.1	1.1	1.3	14.2	3x0.68	4	45	88	1.55
FN5420-5.9-88-E0XXT	5.9	2.2	2.6	7.48	3x1.5	4	76	88	2.2
FN5420-10-88-E0XXT	10.2	4.0	4.8	4.32	3x2.2	4	91	88	5.1
FN5420-13-89-E0XXT	13.2	5.5	6.6	3.34	3x3.0	4	123	89	5.5
FN5420-18-89-E0XXT	18	7.5	9.0	2.45	3x3.7	4	150	89	6.6
FN5420-26-92-E0XXT	26	11	13	1.70	3x5	4	127	92	9.5
FN5420-32-92-E0XXT	32	15	18	1.38	3x6	4	196	92	11.9
FN5420-38-92-E0XXT	38	19	22	1.16	3x8	4	229	92	12.1
FN5420-45-92-E0XXT	45	22	26	0.980	3x8	4	272	92	13.7
FN5420-60-92-E0XXT	60	30	36	0.735	3x12	4	283	92	18.5
FN5420-75-99-E0XXT	75	37	44	0.588	3x15	4	154	99	21.5
FN5420-90-99-E0XXT	90	45	54	0.490	3x20	4	239	99	25.0
FN5420-110-99-E0XXT	110	55	66	0.401	3x20	4	283	99	28.5
FN5420-145-99-E0XXT	145	75	90	0.304	3x100	2	472	99	56
FN5420-180-99-E0XXT	180	90	108	0.245	3x150	2	658	99	58
FN5420-200-99-E0XXT	200	110	132	0.221	3x150	2	707	99	60
FN5420-250-99-E0XXT	250	132	158	0.176	3x200	2	882	99	76
FN5420-300-99-E0XXT	302	160	192	0.146	3x250	2	936	99	98
FN5420-400-99-E0XXT	400	200	240	0.110	3x300	2	1023	99	128
FN5420-480-99-E0XXT	477	250	300	0.092	3x350	2	1318	99	155
FN5420-630-99-E0XXT	630	315	378	0.070	3x500	2	1459	99	185
FN5420-710-99-E0XXT	710	355	426	0.062	3x550	2	1922	99	220
FN5420-800-99-E0XXT	800	400	480	0.055	3x600	2	2062	99	262
FN5420-1000-99-E0XXT	1000	500	600	0.044	3x750	2	2315	99	366

* General purpose four-pole (1500 r/min) AC induction motor rated 400 V/50 Hz.

** General purpose four-pole (1500 r/min) AC induction motor rated 480 V/50 Hz.

*** Total capacitance value. Capacitor connection in delta (Δ) for all versions.

**** See user and installation manual for calculation of the filter power loss at other operation point. Exact value of the complete system depends on the motor cable length and type, switching frequency and further stray parameters of the system.

Required drive settings

Ensure the drive's switching frequency is set to the required minimum switching frequency (see filter selection table). The mode of operation, for both motor- and regenerative load, must be "scalar" (V/Hz) with a fixed switching frequency. Check the drives manufacturer manual whether special settings are necessary. In any doubt contact the drives manufacturer. CAUTION: If the motor drives settings are not correct the filter may be damaged.

Filter Selection Table FN 5420 IP20

Filter	Rated current @ 45°C/ 50Hz [A]	Typical motor drive power rating @ 400 V* [kW]	Typical motor drive power rating @ 480 V** [kW]	Nominal inductance [mH]	Nominal capacitance*** [μF]	Min. switching frequency [kHz]	Typical power loss**** [W]	Input/ Output terminals	Weight [kg]	Frame size
FN5420-2.3-44-E2XXT	2.3	0.75	0.9	19.2	3x0.47	4	41	44	2.4	A
FN5420-3.1-44-E2XXT	3.1	1.1	1.3	14.2	3x0.68	4	45	44	2.8	A
FN5420-5.9-44-E2FXT	5.9	2.2	2.6	7.48	3x1.5	4	76	44	4.0	B
FN5420-10-44-E2FXT	10.2	4.0	4.8	4.32	3x2.2	4	91	44	6.8	B
FN5420-13-33-E2FXT	13.2	5.5	6.6	3.34	3x3.0	4	123	44	7.2	C
FN5420-18-33-E2FXT	18	7.5	9.0	2.45	3x3.7	4	150	33	7.9	C
FN5420-26-33-E2FXT	26	11	13	1.70	3x5	4	127	33	11.8	C
FN5420-32-33-E2FXT	32	15	18	1.38	3x6	4	196	33	14.2	C
FN5420-38-33-E2FXT	38	18.5	22	1.16	3x8	4	229	33	14.4	C
FN5420-45-34-E2FXT	45	22	26	0.980	3x8	4	272	34	21	D
FN5420-60-34-E2FXT	60	30	36	0.735	3x12	4	283	34	25	D
FN5420-75-35-E2FXT	75	37	44	0.588	3x15	4	154	35	30	E
FN5420-90-35-E2FXT	90	45	54	0.490	3x20	4	239	35	34	E
FN5420-110-35-E2FXT	110	55	66	0.401	3x20	4	283	35	38	E

* General purpose four-pole (1500 r/min) AC induction motor rated 400 V/50 Hz.

** General purpose four-pole (1500 r/min) AC induction motor rated 480 V/50 Hz.

*** Total capacitance value. Capacitor connection in delta (Δ) for all versions.

**** See user and installation manual for calculation of the filter power loss at other operation point. Exact value of the complete system depends on the motor cable length and type, switching frequency and further stray parameters of the system.

Required drive settings

Ensure the drive's switching frequency is set to the required minimum switching frequency (see filter selection table). The mode of operation, for both motor- and regenerative load, must be "scalar" (V/Hz) with a fixed switching frequency. Check the drives manufacturer manual whether special settings are necessary. In any doubt contact the drives manufacturer. **CAUTION:** If the motor drives settings are not correct the filter may be damaged.

Mechanical Data FN 5420 IP00

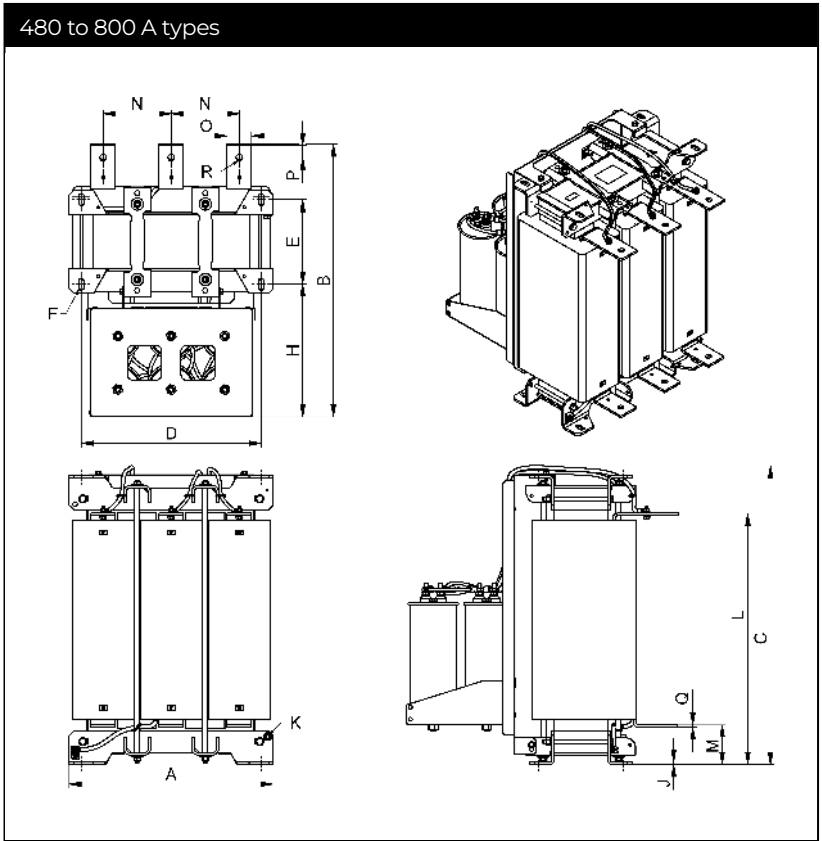
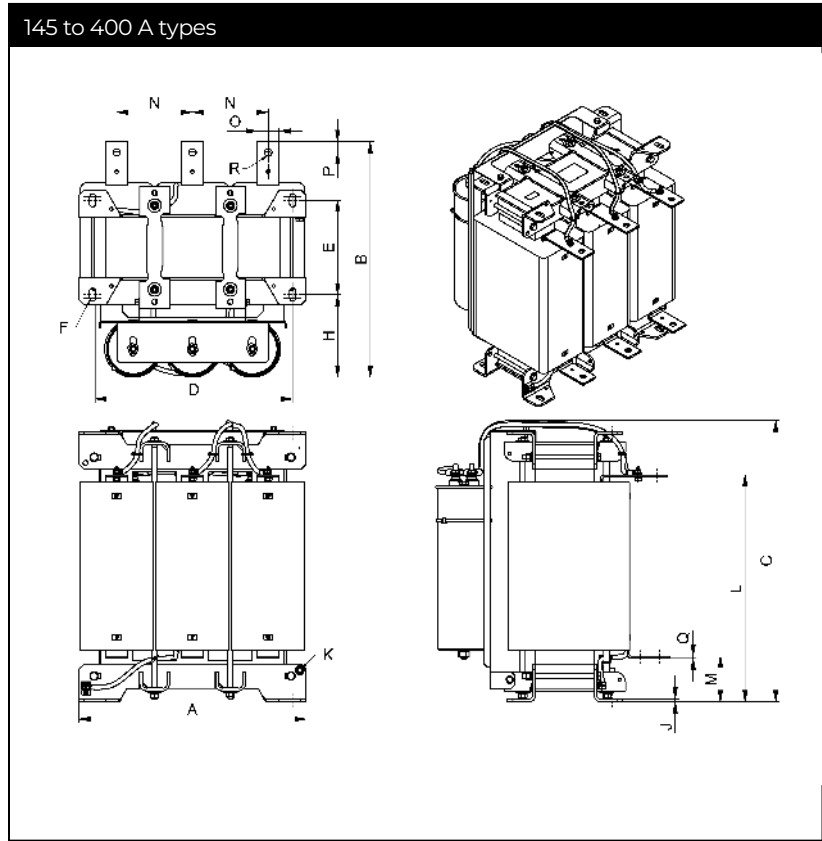
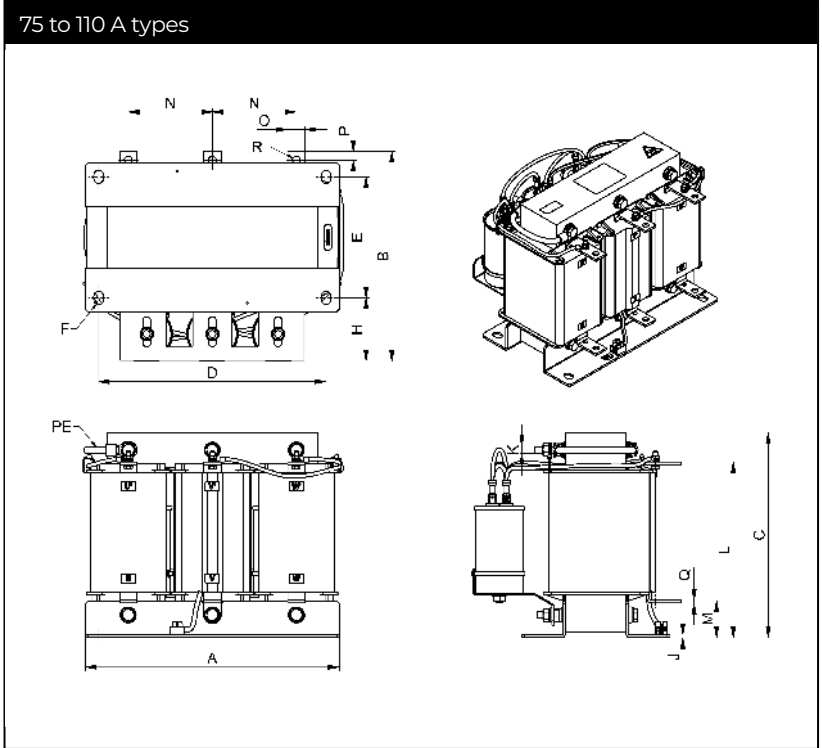
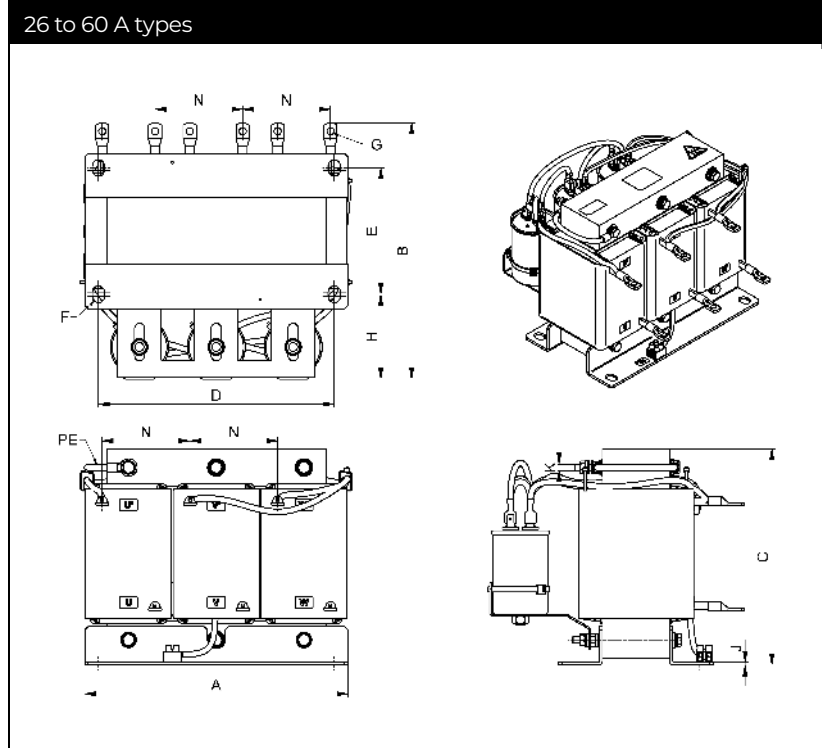
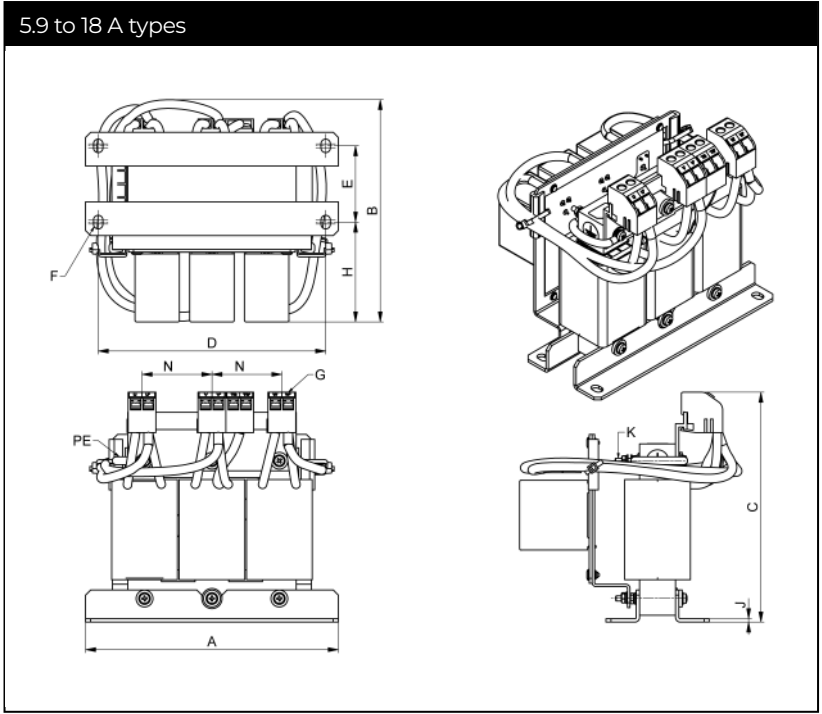
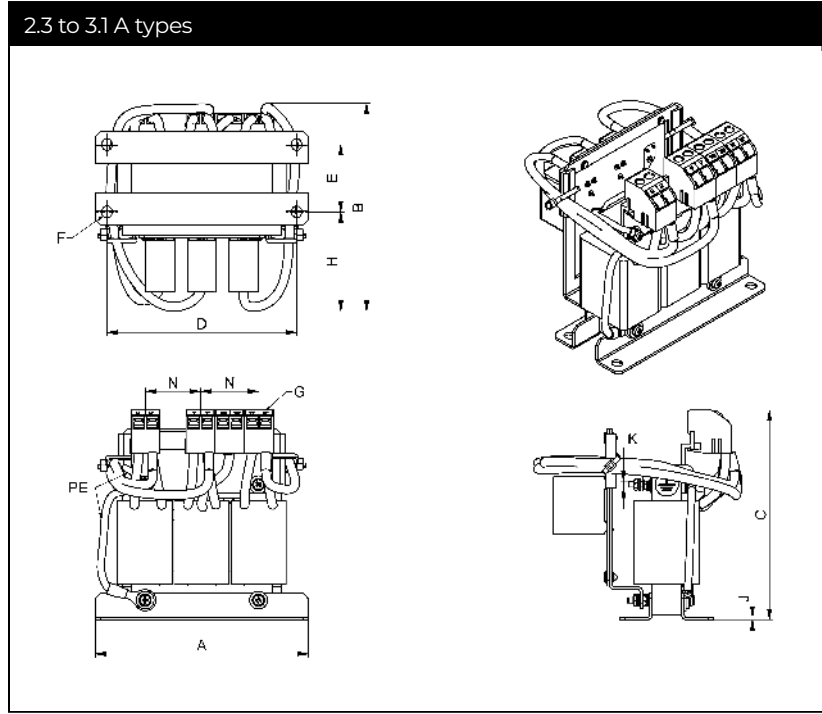

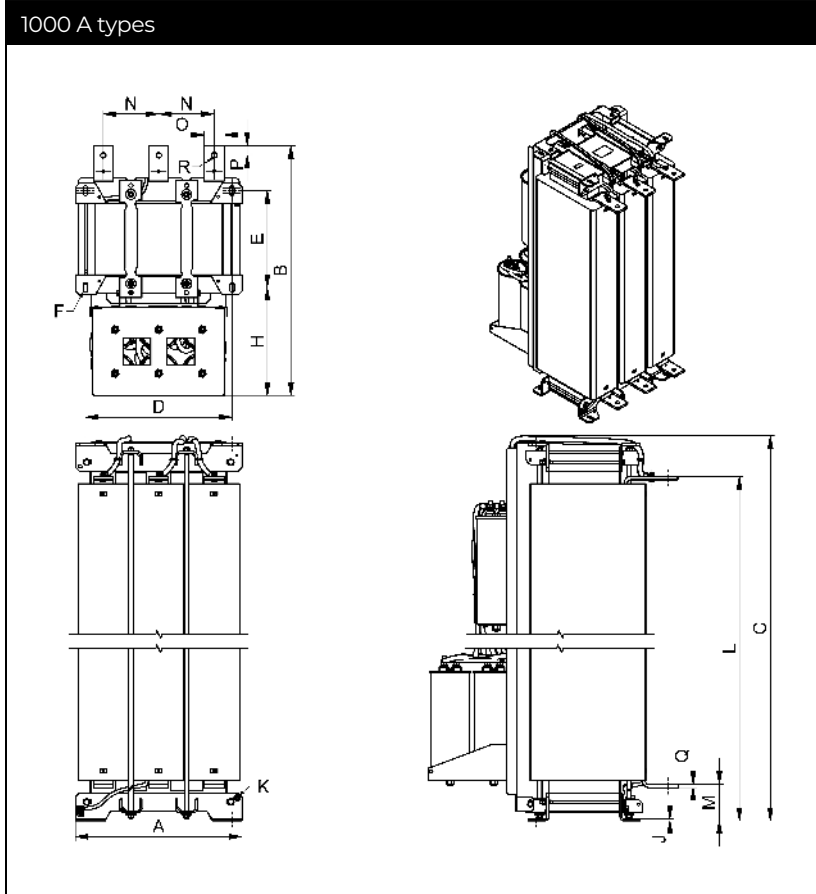

Dimensions FN 5420 IP00

Filter	A	B±5	C±3	D	E	F	G	H	J	K	L±5	M±5	N±5	O	P	Q	R
2.3	120	115	118	107	38	6.5x5.5	-88	56	1.5	M3	-	-	32	-	-	-	-
3.1	120	120	118	107	47.2	6.5x5.5	-88	50	1.5	M3	-	-	32	-	-	-	-
5.9	150	130	137	135	45.3	8x5.5	-88	60	2	M3	-	-	42	-	-	-	-
10.2	195	156	159	170	71.5	12x9	-88	62	2.5	M4	-	-	50	-	-	-	-
13.2	195	148	160	170	71.5	12x9	-89	58	2.5	M4	-	-	50	-	-	-	-
18	220	145	183	200	57.5	12x9	-89	67	2.5	M6	-	-	60	-	-	-	-
26	220	197	158	200	77.5	12x9	ø6.5	71	2.5	M6	-	-	60	-	-	-	-
32	240	196	179	220	84.5	12x9	ø6.4	65	2.5	M6	-	-	68	-	-	-	-
38	240	196	179	220	84.5	12x9	ø6.4	65	2.5	M6	-	-	68	-	-	-	-
45	240	193	198	215	95	15x11	ø6.4	58	3	M6	-	-	80	-	-	-	-
60	240	233	198	215	115	15x11	ø6.4	77	3	M6	-	-	80	-	-	-	-
75	240	242	223	215	129	15x11	-	77	3	M6	170	37	80	20	10	3	ø9
90	265	243	218	240	126	15x11	-	79	3	M8	185	42	88	20	10	3	ø9
110	290	240	234	260	138	15x11	-	72	3	M8	201	43	96	20	10	3	ø9
145	420	338	371	370	134	24x11	-	140	5	M8	263	79	140	25	12.5	4	ø11
180	420	343	370	370	134	24x11	-	142	5	M8	264	80	140	25	12.5	4	ø11
200	420	356	371	370	134	24x11	-	142	5	M8	265	81	140	25	12.5	4	ø11
250	420	387	436	370	134	24x11	-	152	5	M8	321	87	140	40	20	4	ø13.5
302	420	430	422	370	174	24x11	-	152	5	M8	314	80	140	40	20	4	ø13.5
400	420	434	531	370	174	24x11	-	152	5	M8	418	84	140	40	20	4	ø13.5
477	420	560	627	370	174	24x11	-	273	5	M8	518	83	140	50	25	5	ø13.5
630	420	560	755	370	174	24x11	-	273	5	M8	631	96	140	50	25	5	ø13.5
710	420	600	726	370	214	24x11	-	273	5	M8	617	82	140	50	25	5	ø13.5
800	420	602	854	370	214	24x11	-	273	5	M8	734	96	140	50	25	8	ø13.5
1000	420	631	1050	370	244	24x11	-	273	5	M8	930	92	140	50	25	8	ø13.5

All dimensions in mm; 1 inch = 25.4 mm

Tolerances according: ISO 2768-m / EN 22768-m

Power Terminals

Terminal designation	Recommended connector type	Screw thread	Flex wire AWG	Flex wire	Screw torque value	Max width cable lug*
				[mm ²]	[Nm]	[mm]
88	Fork cable shoe	M3.5	20-16	0.5-1.5	0.78	6.4
89	Fork cable shoe	M4	18-12	0.5-2.5	1.76	8
92	Ring cable shoe	M6	-	-	-	-
99	Ring cable shoe	M8/M10/M12	-	-	-	-

* To fulfill creepage/clearance acc. UL 61800-5-1 without additional protection (insulation). Creepage/clearance can vary depending on applicable standard and must be reviewed by customer. Creepage/clearance may be reduced when additional protection (insulation) is provided.

Auxiliary Terminals

Filter size	Recommended connector type	Screw thread	Flex wire AWG	Flex wire	Screw torque value	Max width cable lug
				[mm ²]	[Nm]	[mm]
2.3A & 3.1A	Fork cable shoe	M3.5	20-16	0.5-1.5	0.78	6.4
5.9 to 18A	Fork cable shoe	M4	18-12	0.5-2.5	1.76	8.0
26A to 1000A	No connector	-	20-14	0.5-2.5	0.4	-

Earth Terminals

Filter size	Screw thread	Screw torque value [Nm]
2.3 to 5.9A	M3	0.6
10 to 13A	M4	1.7
18 to 75A	M6	4
90 to 1000A	M8	9

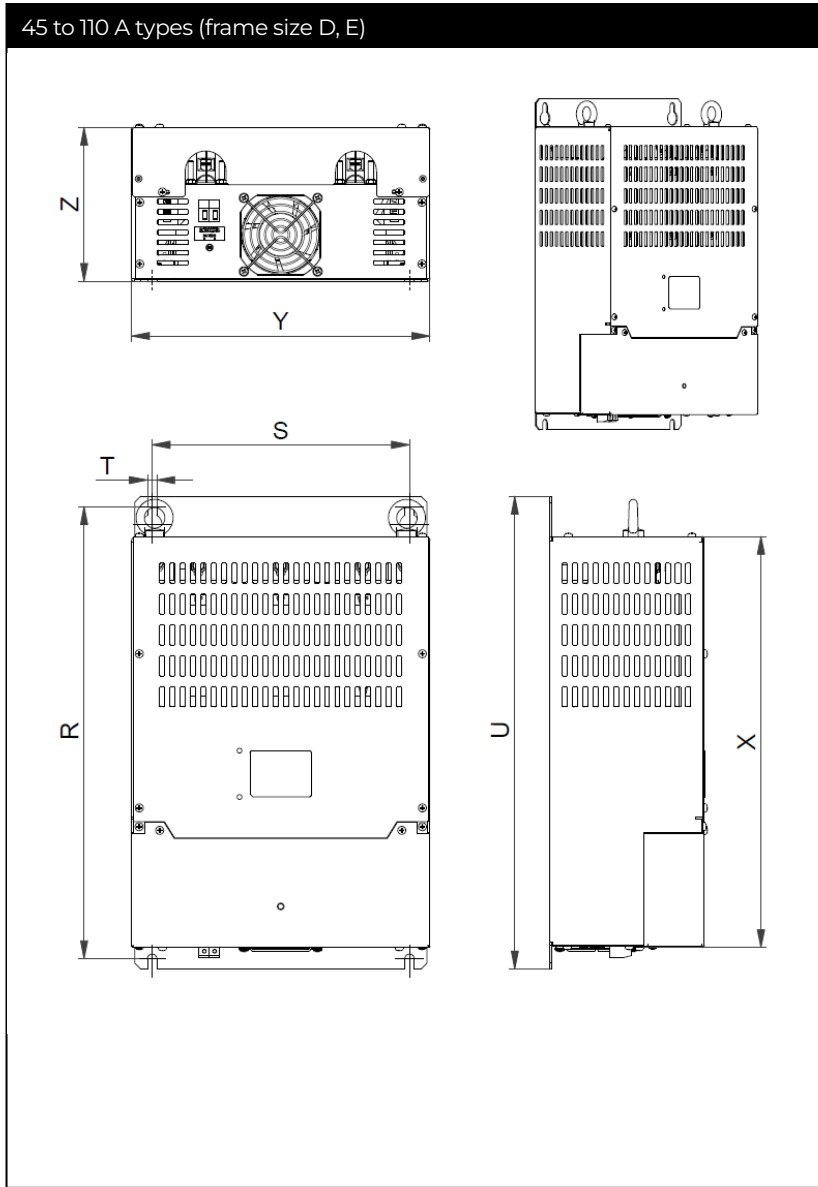
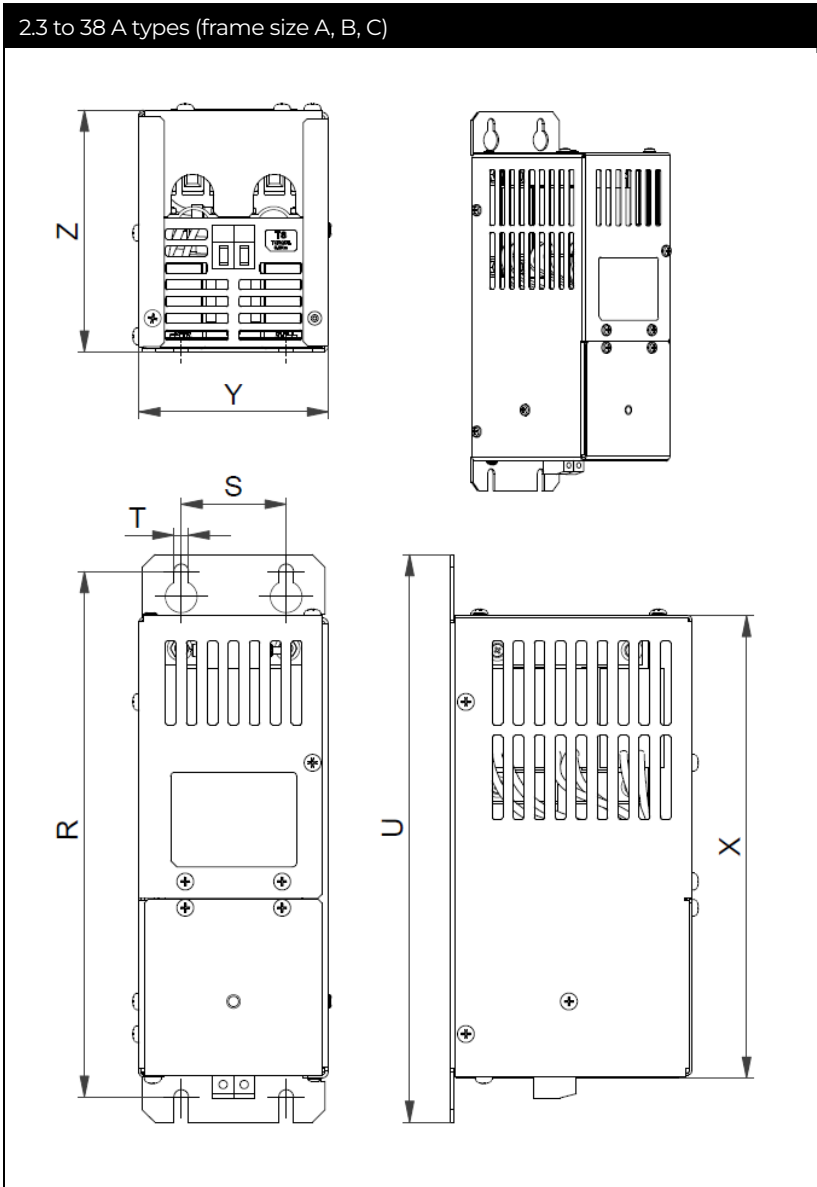

Dimensions FN 5420 IP20

Frame	Drill pattern			Base	Box size		
Type	R +2/0	S	T	U	X ±2	Y	Z ±2
A	250	50	7	270	220	90	115
B	310	60	7	330	280	100	165
C	405	90	7	425	375	130	225
D	440	250	9	460	400	290	150
E	510	290	9	530	470	330	170

All dimensions in mm; 1 inch = 25.4 mm
 Tolerances according: ISO 2768-m / EN 22768-m

Power Terminals

Terminal designation	Recommended connector type	Solid wire	Flex wire	Flex wire	Screw torque value
		[mm ²]	[AWG]	[mm ²]	[Nm]
44	No connector	0.5 - 10	20 - 8	0.5 - 6	1.0 - 1.2
33	No connector	0.5 - 16	20 - 6	0.5 - 10	1.5 - 1.8
34	No connector	6 - 35	10 - 2	6 - 25	4.0 - 4.5
35	No connector	10 - 50	6 - 1/0	16 - 50	7.0 - 8.0

Auxiliary Terminals

Filter frame size	Function	Recommended connector type	Solid wire	Flex wire	Flex wire	Screw torque value
			[mm ²]	[AWG]	[mm ²]	[Nm]
All sizes	Thermal switch signal	No connector	0.5 - 6	24 - 10	0.5 - 4	0.7 - 0.8
All sizes	24V fan power input	No connector	0.5 - 6	24 - 10	0.5 - 4	0.7 - 0.8

Earth Terminals

Filter frame type	Screw thread	Screw torque value [Nm]
A, B, C and D	M5	2.2
E	M8	9.0

Headquarters, Global Innovation and Development

Switzerland

Schaffner Group

Industrie Nord
Nordstrasse 11e
4542
Luterbach
+41 32 681 66 26
info@schaffner.com

Sales and Application Centers

Switzerland

Schaffner EMV AG

Industrie Nord
Nordstrasse 11e
4542
Luterbach
+41 32 681 66 26
switzerlandsales@schaffner.com

China

Schaffner EMC Ltd. Shanghai

T20-3 C No 565 Chuangye Road Pudong district
201201
Shanghai
+86 2138139500
cschina@schaffner.com

Singapore

Schaffner EMC Pte Ltd.

Blk 3015A Ubi Road 1 #05-09 Kampong Ubi Industrial Estate
408705
Singapore
+65 63773283
singaporesales@schaffner.com

To find your local partner within Schaffner's global network schaffner.com

© 2023 Schaffner Group

The content of this document has been carefully checked and understood. However, neither Schaffner nor its subsidiaries assume any liability whatsoever for any errors or inaccuracies of this document and the consequences thereof. Published specifications are subject to change without notice. Product suitability for any area of application must ultimately be determined by the customer. In all cases, products must never be operated outside their published specifications. Schaffner does not guarantee the availability of all published products. This disclaimer shall be governed by substantive Swiss law and resulting disputes shall be settled by the courts at the place of business of Schaffner Holding AG. Latest publications and a complete disclaimer can be downloaded from the Schaffner website. All trademarks recognized.