

THIS DRAWING IS UNPUBLISHED. RELEASED FOR PUBLICATION
 © COPYRIGHT - By - ALL RIGHTS RESERVED.

REVISIONS				
P	LTR	DESCRIPTION	DATE	APVD
E		REV PER ECO 16-003934	3-15-16	CT CD

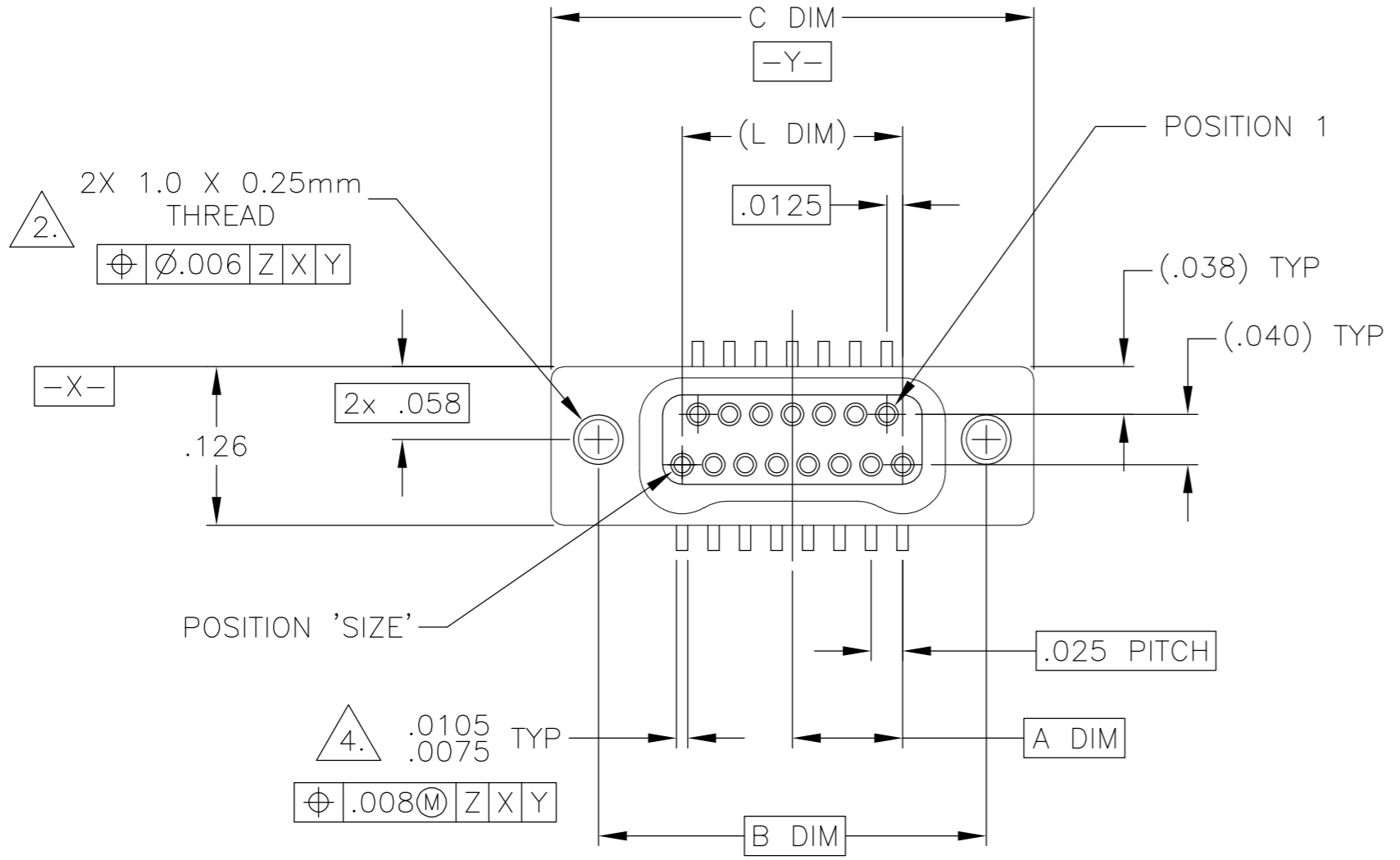

SIZE	A DIM	B DIM	C DIM ±.0050	(L DIM)
09	.050	.229	.3085	(.100)
15	.0875	.304	.3835	(.175)
25	.150	.429	.5085	(.300)
31	.1875	.504	.5835	(.375)
37	.225	.579	.6585	(.450)
51	.3125	.754	.8335	(.625)
65	.400	.929	1.0085	(.800)

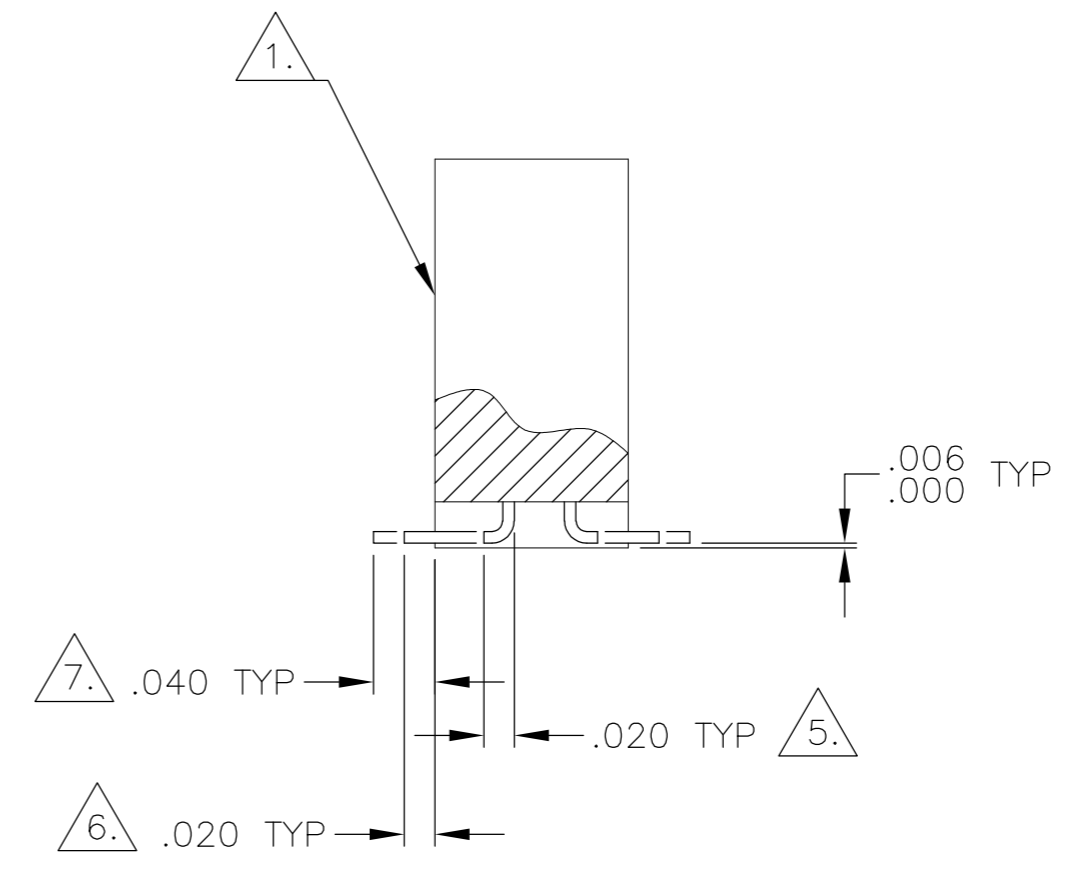
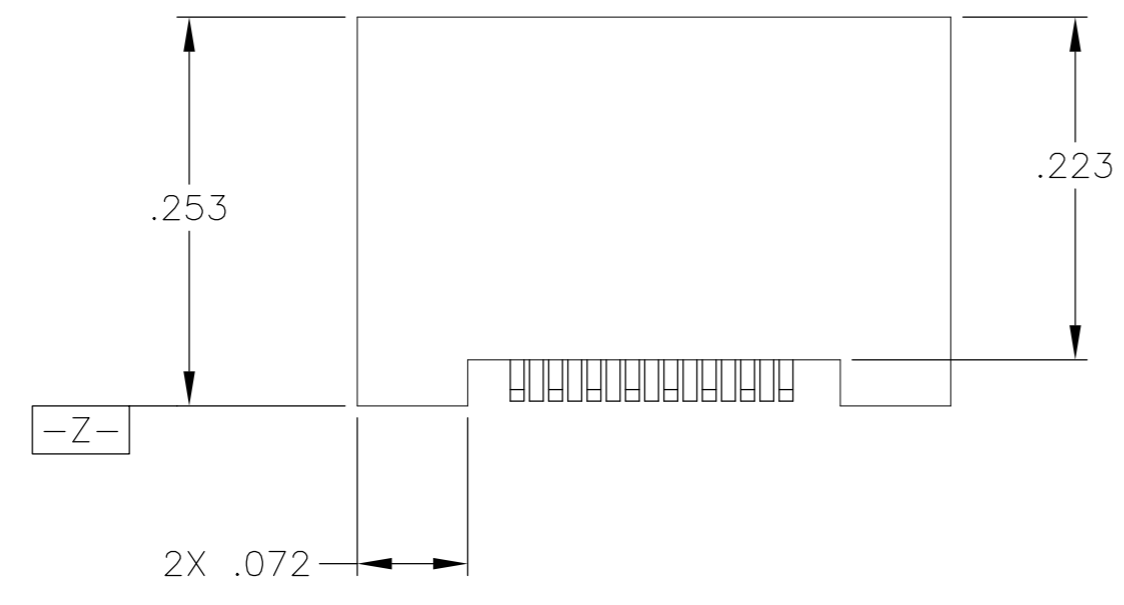

- 1. SHELL OPTIONS (TO BE SPECIFIED IN NANONICS PART NUMBER):
 METAL: 6061-T6 ALUMINUM, ELECTROLESS NICKEL PLATED PER MIL-C-26074 (STANDARD) OR GOLD PLATED PER MIL-G-45204
 303 STAINLESS STEEL, PASSIVATED PER SAE-AMS-QQ-P-35
 INSULATOR MATERIAL FOR ALL METAL SHELLS IS LIQUID CRYSTAL POLYMER (LCP) PER MIL-M-24519 OR PER ASTM D5138
- 2. STANDARD 1.0 X 0.25mm JACKSCREW AND MOUNTING THREADS ARE SHOWN FOR REFERENCE ONLY AND MUST BE SPECIFIED IN THE NANONICS PART NUMBER WHEN REQUIRED. 1.2 X 0.25mm THREADS ALSO AVAILABLE.
- 3. MOUNTING HARDWARE IS AVAILABLE WITH THIS CONFIGURATION (NOT SHOWN). HARDWARE MUST BE SPECIFIED IN THE NANONICS PART NUMBER. CONSULT TYCO ELECTRONICS FOR DETAILS.
- 4. SMT LEADS ARE BeCu, TIN LEAD PLATED 60/40 COMPOSITION PER SAE-AMS-P-81728.
- 5. NANONICS TERMINATION CODE: L8
- 6. NANONICS TERMINATION CODE: L82
- 7. NANONICS TERMINATION CODE: L84
- 8. THIS DRAWING PREVIOUSLY IDENTIFIED AS NANONICS N10138/246
- 9. POSITIONAL TOLERANCES FOR BASIC DIMENSIONED FEATURES ARE RELATIVE TO FIDUCIALS OR SOME SIMILAR DATUM REFERENCE DEFINED BY THE PCB DESIGNER.

THIS DRAWING IS A CONTROLLED DOCUMENT.		DWN C. SCHOLL 2 APR 01		
DIMENSIONS: INCHES		CHK M. STORRY 2 APR 01		
TOLERANCES UNLESS OTHERWISE SPECIFIED:		APVD M. STORRY 4-2-01	NAME RECEPTACLE ASSEMBLY, VERTICAL SURFACE MOUNT, TWO ROW DUALLOBE, METAL, W/INTEGRATED STANDOFFS	
0 PLC ± -		PRODUCT SPEC	SIZE A2	CAGE CODE 00779
1 PLC ± -		APPLICATION SPEC	DRAWING NO C=1589486	RESTRICTED TO -
2 PLC ± .010		WEIGHT 0	SCALE 8:1	SHEET 1 of 2
3 PLC ± .005		CUSTOMER DRAWING	REV E	
4 PLC ± -				
ANGLES ± 1				
MATERIAL SEE NOTES	FINISH SEE NOTES			

THIS DRAWING IS UNPUBLISHED. RELEASED FOR PUBLICATION
 © COPYRIGHT - By - ALL RIGHTS RESERVED.

REVISIONS				
P	LTR	DESCRIPTION	DATE	APVD
-	-	SEE SHEET #1	-	-

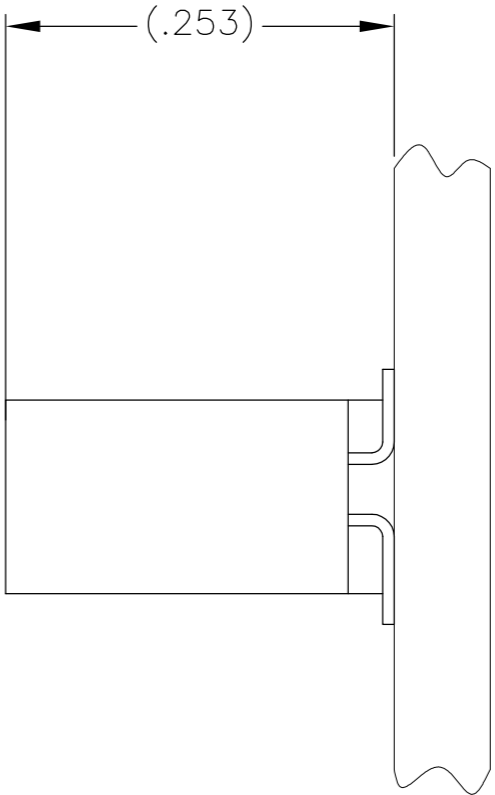
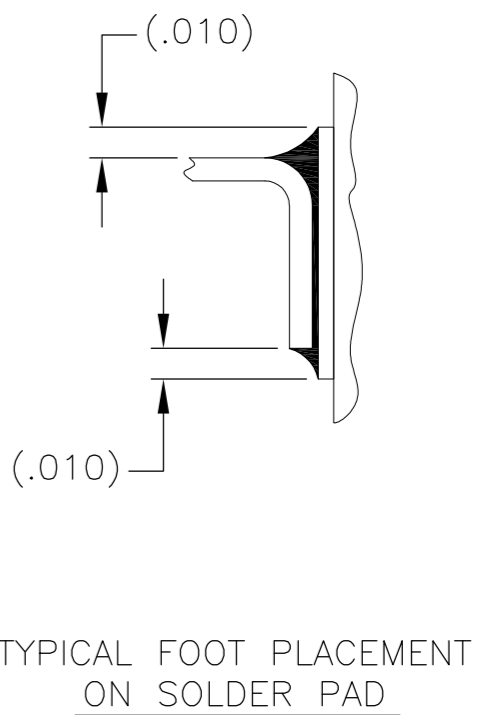
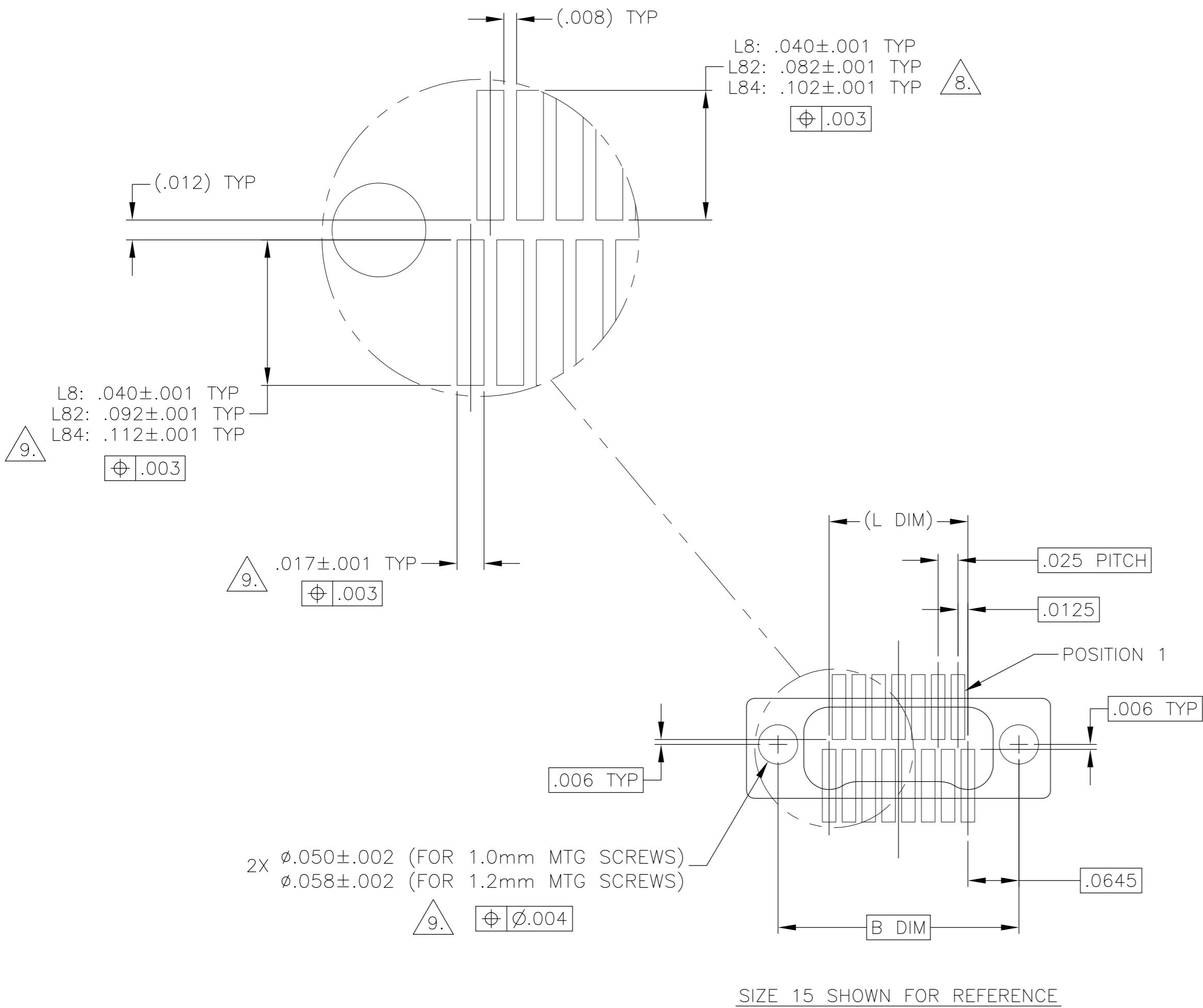

SIZE 15 SHOWN FOR REFERENCE

TYPICAL PCB LAYOUT

THIS DRAWING IS A CONTROLLED DOCUMENT.		DWN C. SCHOLL 2 APR 01	TE Connectivity																			
DIMENSIONS: INCHES		CHK M. STORRY 2 APR 01																				
TOLERANCES UNLESS OTHERWISE SPECIFIED:		APVD M. STORRY 4-2-01	NAME RECEPTACLE ASSEMBLY, VERTICAL SURFACE MOUNT, TWO ROW DUALLOBE, METAL, W/INTEGRATED STANDOFFS																			
<table border="1"> <tr><td>0 PLC</td><td>±</td><td>-</td></tr> <tr><td>1 PLC</td><td>±</td><td>-</td></tr> <tr><td>2 PLC</td><td>±</td><td>.010</td></tr> <tr><td>3 PLC</td><td>±</td><td>.005</td></tr> <tr><td>4 PLC</td><td>±</td><td>-</td></tr> <tr><td>ANGLES</td><td></td><td>± 1</td></tr> </table>		0 PLC	±	-	1 PLC	±	-	2 PLC	±	.010	3 PLC	±	.005	4 PLC	±	-	ANGLES		± 1	PRODUCT SPEC -	SIZE A2	CAGE CODE 00779
0 PLC	±	-																				
1 PLC	±	-																				
2 PLC	±	.010																				
3 PLC	±	.005																				
4 PLC	±	-																				
ANGLES		± 1																				
MATERIAL SEE NOTES		FINISH SEE NOTES	WEIGHT 0	DRAWING NO C=1589486																		
CUSTOMER DRAWING		SCALE 8:1	SHEET 2 of 2	REV E																		