

FEATURES

- Radio frequency (RF) bandwidth to 6.1 GHz
- 25-bit fixed modulus allows subhertz frequency resolution
- Frequency and phase modulation capability
- Sawtooth and triangular waveforms in the frequency domain
- Parabolic ramp
- Ramp superimposed with FSK
- Ramp with 2 different sweep rates
- Ramp delay
- Ramp frequency readback
- Ramp interruption
- 2.7 V to 3.3 V power supply
- Separate V_P allows extended tuning voltage
- Programmable charge pump currents
- 3-wire serial interface
- Digital lock detect
- Power-down mode
- Cycle slip reduction for faster lock times
- Switched bandwidth fast lock mode
- Qualified for automotive applications

APPLICATIONS

- Frequency modulated continuous wave (FMCW) radar
- Communications test equipment

GENERAL DESCRIPTION

The **ADF4158** is a 6.1 GHz, fractional-N frequency synthesizer with direct modulation and waveform generation capability. It contains a 25-bit fixed modulus, allowing subhertz resolution at 6.1 GHz. It consists of a low noise digital phase frequency detector (PFD), a precision charge pump, and a programmable reference divider. There is a sigma-delta (Σ - Δ) based fractional interpolator to allow programmable fractional-N division. The INT and FRAC registers define an overall N-divider as $N = INT + (FRAC/2^{25})$.

The **ADF4158** can be used to implement frequency shift keying (FSK) and phase shift keying (PSK) modulation. There are also a number of frequency sweep modes available that generate various waveforms in the frequency domain, for example, sawtooth and triangular waveforms. The **ADF4158** features cycle slip reduction circuitry, which leads to faster lock times, without the need for modifications to the loop filter.

Control of all on-chip registers is via a simple 3-wire interface. The device operates with a power supply ranging from 2.7 V to 3.3 V and can be powered down when not in use.

FUNCTIONAL BLOCK DIAGRAM

Figure 1.

08728-001

Rev. I

[Document Feedback](#)

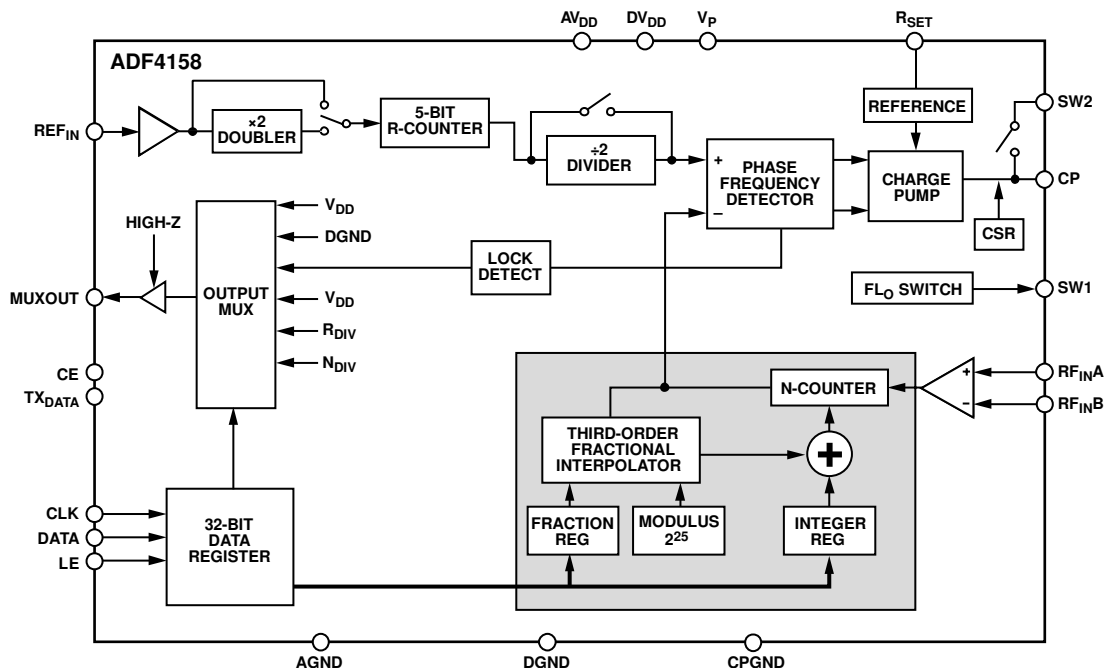
Information furnished by Analog Devices is believed to be accurate and reliable. However, no responsibility is assumed by Analog Devices for its use, nor for any infringements of patents or other rights of third parties that may result from its use. Specifications subject to change without notice. No license is granted by implication or otherwise under any patent or patent rights of Analog Devices. Trademarks and registered trademarks are the property of their respective owners.

One Technology Way, P.O. Box 9106, Norwood, MA 02062-9106, U.S.A.
 Tel: 781.329.4700 ©2010–2018 Analog Devices, Inc. All rights reserved.
[Technical Support](#) www.analog.com

TABLE OF CONTENTS

| | | | |
|---|----|--|----|
| Features | 1 | R-Divider Register (R2) Map | 17 |
| Applications | 1 | Function Register (R3) Map | 19 |
| General Description | 1 | Test Register (R4) Map | 21 |
| Functional Block Diagram | 1 | Deviation Register (R5) Map | 22 |
| Revision History | 3 | Step Register (R6) Map | 23 |
| Specifications | 4 | Delay Register (R7) Map | 24 |
| Timing Specifications | 5 | Applications Information | 25 |
| Absolute Maximum Ratings | 7 | Initialization Sequence | 25 |
| ESD Caution | 7 | RF Synthesizer: A Worked Example | 25 |
| Pin Configuration and Pin Function Descriptions | 8 | Reference Doubler and Reference Divider | 25 |
| Typical Performance Characteristics | 9 | Cycle Slip Reduction for Faster Lock Times | 25 |
| Circuit Description | 11 | Modulation | 26 |
| Reference Input Section | 11 | Waveform Generation | 26 |
| RF Input Stage | 11 | Other Waveforms | 28 |
| RF INT Divider | 11 | External Control of Ramp Steps | 30 |
| 25-Bit Fixed Modulus | 11 | Fast Lock Mode | 32 |
| INT, FRAC, and R Relationship | 11 | Spur Mechanisms | 33 |
| R-Counter | 12 | Low Frequency Applications | 33 |
| Phase Frequency Detector (PFD) and Charge Pump | 12 | Filter Design—ADIsimPLL | 33 |
| MUXOUT and LOCK Detect | 12 | PCB Design Guidelines for the Chip Scale Package | 33 |
| Input Shift Registers | 12 | Application of ADF4158 in FMCW Radar | 34 |
| Program Modes | 12 | Outline Dimensions | 35 |
| Register Maps | 13 | Ordering Guide | 35 |
| FRAC/INT Register (R0) Map | 15 | Automotive Products | 35 |
| LSB FRAC Register (R1) Map | 16 | | |

REVISION HISTORY**6/2018—Rev. H to Rev. I**

| | |
|---------------------------------|----|
| Updated Outline Dimensions..... | 35 |
| Changes to Ordering Guide..... | 35 |

8/2017—Rev. G to Rev. H

| | |
|---------------------------------|------------|
| Changed CP-24-7 to CP-24-8..... | Throughout |
| Changes to Figure 5..... | 8 |
| Updated Outline Dimensions..... | 35 |
| Changes to Ordering Guide..... | 35 |

3/2014—Rev. F to Rev. G

| | |
|---|----|
| Changes to Timeout Interval Section | 27 |
|---|----|

2/2014—Rev. E to Rev. F

| | |
|---|----|
| Changed CKJ to CLK, Table 3 | 6 |
| Changed V_{DD} to V_{DD} Parameter to DV_{DD} to AV_{DD} Parameter, Table 4..... | 7 |
| Changes to 25-Bit Fixed Modulus Section..... | 11 |
| Changes to Figure 22 | 14 |
| Added Σ - Δ Modulator Mode Section..... | 21 |
| Changed 12-Bit Clock Divider Value Section to 12-Bit CLK_2 Divider Value Section | 21 |
| Changes to Clock Divider (DIV) Mode, 12-Bit CLK_2 Divider Value Section, and Figure 27 | 21 |
| Changes to Frequency Deviation Section and Timeout Interval Section | 27 |
| Changes to FMCW Radar Ramp Settings Worked Example Section | 28 |
| Added External Control of Ramp Steps Section..... | 30 |
| Changes to Figure 42 | 30 |
| Changes to Interrupt Modes and Frequency Readback Section | 31 |
| Added Fast Lock Mode Section..... | 32 |
| Changes to Fast Lock Timer and Register Sequences Section, Fast Lock Example Section, and Fast Lock: Loop Filter Topology Section | 32 |

3/2013—Rev. D to Rev. E

| | |
|--|----|
| Changes to Figure 7, Figure 8, Figure 9, and Figure 10..... | 9 |
| Changes to Figure 22 | 14 |
| Changes to Negative Bleed Current Section, Readback to MUXOUT Section, and Figure 27 | 21 |
| Changes to Figure 28 | 22 |
| Changes to FMCW Radar Ramp Settings Worked Example Section | 27 |

6/2012—Rev. C to Rev. D

| | |
|---|----|
| Changes to Table 3 and Figure 3 | 6 |
| Added Figure 4; Renumbered Sequentially | 6 |
| Added Negative Bleed Current Section..... | 21 |
| Changes to Figure 27 | 21 |

12/2011—Rev. B to Rev. C

| | |
|---|----|
| Changes to Features Section | 1 |
| Changes to Figure 6 Caption and Figure 9 Caption | 9 |
| Changes to Figure 11 | 10 |
| Changes to Figure 19 | 12 |
| Changes to Figure 20 | 13 |
| Changed 12-Bit MOD Divider Section to 12-Bit CLK_1 Divider Section | 17 |
| Changes to 12-Bit CLK_1 Divider Section | 17 |
| Changes to Figure 24 | 18 |
| Changes to Delay Clock Select Section and Figure 29 | 24 |
| Changes to Timeout Interval Section..... | 27 |
| Changes to FMCW Radar Ramp Settings Worked Example Section | 28 |
| Changes to Delayed Start, Example Section and Delay Between Ramps, Example Section | 29 |
| Changes to Fast-Lock Timer and Register Sequences Section and Fast Lock: An Example Section | 32 |
| Changes to Ordering Guide..... | 35 |
| Added Automotive Products Section | 35 |

9/2011—Rev. A to Rev. B

| | |
|---|---|
| Changes to Noise Characteristics Parameter..... | 3 |
|---|---|

7/2011—Rev. 0 to Rev. A

| | |
|--|----|
| Changes to Figure 21 | 13 |
| Changes to Figure 25 | 19 |
| Changes to 12-Bit Clock Divider Value Section | 20 |
| Changes to Figure 28 | 22 |
| Changes to FMCW Radar Ramp Settings Worked Example Section | 26 |
| Added Ramp Programming Sequence Section, and added Other Waveforms Heading | 27 |
| Changes to Figure 36 | 28 |
| Added Ramp Complete Signal to Muxout Section and changes to Figure 40 | 29 |
| Added Figure 42; Renumbered Sequentially | 30 |
| Changes to Figure 45 | 31 |
| Changes to Figure 46 | 33 |

4/2010—Revision 0: Initial Version

SPECIFICATIONS

$AV_{DD} = DV_{DD} = 2.7\text{ V}$ to 3.3 V , $V_P = AV_{DD}$ to 5.5 V , $AGND = DGND = 0\text{ V}$, $T_A = T_{MIN}$ to T_{MAX} , dBm referred to $50\ \Omega$, unless otherwise noted.

Table 1.

| Parameter | C Version ¹ | | | Unit | Test Conditions/Comments |
|--|------------------------|------------------|------|------|---|
| | Min | Typ | Max | | |
| RF CHARACTERISTICS | | | | | |
| RF Input Frequency (RF _{IN}) | 0.5 | | 6.1 | GHz | –10 dBm minimum to 0 dBm maximum; for lower frequencies, ensure slew rate (SR) > 400 V/μs –15 dBm minimum to 0 dBm maximum for 2 GHz to 4 GHz RF input frequency |
| REFERENCE CHARACTERISTICS | | | | | |
| REF _{IN} Input Frequency | 10 | | 260 | MHz | For f < 10 MHz, use a dc-coupled CMOS-compatible square wave, slew rate > 25 V/μs |
| REF _{IN} Input Sensitivity | 0.4 | | 16 | MHz | If an internal reference doubler is enabled |
| REF _{IN} Input Capacitance | | | 10 | pF | Biased at $AV_{DD}/2^2$ |
| REF _{IN} Input Current | | | ±100 | μA | |
| PHASE DETECTOR | | | | | |
| Phase Detector Frequency ³ | | | 32 | MHz | |
| CHARGE PUMP | | | | | |
| I _{CP} Sink/Source | | | | | Programmable |
| High Value | | 5 | | mA | With R _{SET} = 5.1 kΩ |
| Low Value | | 312.5 | | μA | |
| Absolute Accuracy | | 2.5 | | % | With R _{SET} = 5.1 kΩ |
| R _{SET} Range | 2.7 | | 10 | kΩ | |
| I _{CP} Three-State Leakage Current | | 1 | | nA | Sink and source current |
| Matching | | 2 | | % | $0.5\text{ V} < V_{CP} < V_P - 0.5\text{ V}$ |
| I _{CP} vs. V _{CP} | | 2 | | % | $0.5\text{ V} < V_{CP} < V_P - 0.5\text{ V}$ |
| I _{CP} vs. Temperature | | 2 | | % | $V_{CP} = V_P/2$ |
| LOGIC INPUTS | | | | | |
| V _{INH} , Input High Voltage | 1.4 | | | V | |
| V _{INL} , Input Low Voltage | | | 0.6 | V | |
| I _{INH} /I _{INL} , Input Current | | | ±1 | μA | |
| C _{IN} , Input Capacitance | | | 10 | pF | |
| LOGIC OUTPUTS | | | | | |
| V _{OH} , Output High Voltage | 1.4 | | | V | Open-drain output chosen; 1 kΩ pull-up to 1.8 V |
| V _{OH} , Output High Voltage | V _{DD} – 0.4 | | | V | CMOS output chosen |
| I _{OH} , Output High Current | | | 100 | μA | |
| V _{OL} , Output Low Voltage | | | 0.4 | V | I _{OL} = 500 μA |
| POWER SUPPLIES | | | | | |
| AV _{DD} | 2.7 | | 3.3 | V | |
| DV _{DD} | | AV _{DD} | | | |
| V _P | AV _{DD} | | 5.5 | V | |
| I _{DD} | | 23 | 32 | mA | |

| Parameter | C Version ¹ | | | Unit | Test Conditions/Comments |
|--|------------------------|------|-----|--------|--|
| | Min | Typ | Max | | |
| NOISE CHARACTERISTICS | | | | | |
| Normalized Phase Noise Floor (PN _{SYNTH}) ⁴ | | -216 | | dBc/Hz | PLL loop bandwidth = 500 kHz; measured at 100 kHz offset |
| Normalized 1/f Noise (PN _{1/f}) ⁵ | | -110 | | dBc/Hz | 100 kHz offset; normalized to 1 GHz |
| Phase Noise Performance ⁶ 5805 MHz Output ⁷ | | -93 | | dBc/Hz | At VCO output At 5 kHz offset, 32 MHz PFD frequency |

¹ Operating temperature for C version: -40°C to +125°C.

² AC coupling ensures AV_{DD}/2 bias.

³ Guaranteed by design. Sample tested to ensure compliance.

⁴ The synthesizer phase noise floor is estimated by measuring the in-band phase noise at the output of the VCO and subtracting 20 log(N) (where N is the N divider value) and 10 log(f_{PFD}). PN_{SYNTH} = PN_{TOT} - 10 log(f_{PFD}) - 20 log(N).

⁵ The PLL phase noise is composed of 1/f (flicker) noise plus the normalized PLL noise floor. The formula for calculating the 1/f noise contribution at an RF frequency, f_{RF}, and at a frequency offset f is given by PN_{1/f} + 10 log(10 kHz/f) + 20 log(f_{RF}/1 GHz). Both the normalized phase noise floor and flicker noise are modeled in ADIsimPLL™.

⁶ The phase noise is measured with the EVAL-ADF4158EB1Z and the Agilent E5052A phase noise system.

⁷ f_{REFIN} = 128 MHz; f_{PFD} = 32 MHz; offset frequency = 5 kHz; RF_{OUT} = 5805 MHz; INT = 181; FRAC = 13631488; loop bandwidth = 100 kHz.

TIMING SPECIFICATIONS

AV_{DD} = DV_{DD} = SDV_{DD} = 2.7 V to 3.3 V; V_P = AV_{DD} to 5.5 V; AGND = DGND = SDGND = 0 V; T_A = T_{MIN} to T_{MAX}, dBm referred to 50 Ω, unless otherwise noted.

Table 2. Write Timing

| Parameter | Limit at T _{MIN} to T _{MAX} (C Version) | Unit | Test Conditions/Comments |
|----------------|---|--------|--------------------------|
| t ₁ | 20 | ns min | LE setup time |
| t ₂ | 10 | ns min | DATA to CLK setup time |
| t ₃ | 10 | ns min | DATA to CLK hold time |
| t ₄ | 25 | ns min | CLK high duration |
| t ₅ | 25 | ns min | CLK low duration |
| t ₆ | 10 | ns min | CLK to LE setup time |
| t ₇ | 20 | ns min | LE pulse width |

Write Timing Diagram

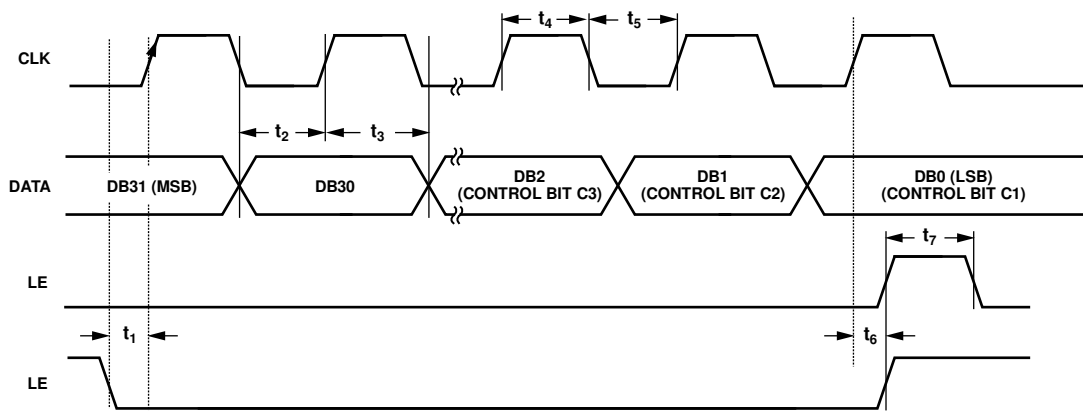

Figure 2. Write Timing Diagram

08728-026

Table 3. Read Timing

| Parameter | Limit at T _{MIN} to T _{MAX} (C Version) | Unit | Test Conditions/Comments |
|----------------|---|--------|------------------------------------|
| t ₁ | 20 | ns min | TX _{DATA} setup time |
| t ₂ | 20 | ns min | CLK setup time to DATA (on MUXOUT) |
| t ₃ | 25 | ns min | CLK high duration |
| t ₄ | 25 | ns min | CLK low duration |
| t ₅ | 10 | ns min | CLK to LE setup time |

Read Timing Diagram

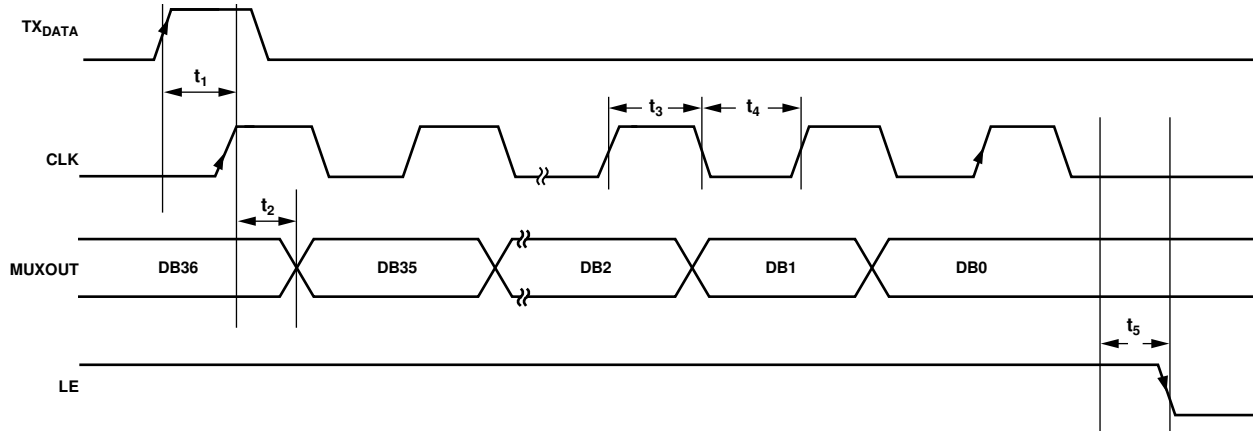

NOTES
1. LE SHOULD BE KEPT HIGH DURING READBACK.

Figure 3. Read Timing Diagram

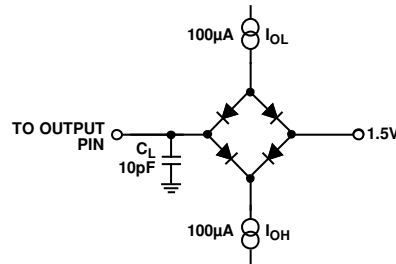

Figure 4. Load Circuit for MUXOUT Timing, C_L = 10 pF

08728-226

08728-004

ABSOLUTE MAXIMUM RATINGS

$T_A = 25^\circ\text{C}$, GND = AGND = DGND = SDGND = 0 V,
 $V_{DD} = AV_{DD} = DV_{DD} = SDV_{DD}$, unless otherwise noted.

Table 4.

| Parameter | Rating |
|--|----------------------------|
| V_{DD} to GND | -0.3 V to +4 V |
| DV_{DD} to AV_{DD} | -0.3 V to +0.3 V |
| V_P to GND | -0.3 V to +5.8 V |
| V_P to V_{DD} | -0.3 V to +5.8 V |
| Digital I/O Voltage to GND | -0.3 V to $V_{DD} + 0.3$ V |
| Analog I/O Voltage to GND | -0.3 V to $V_{DD} + 0.3$ V |
| REF_{IN} , RF_{IN} to GND | -0.3 V to $V_{DD} + 0.3$ V |
| Operating Temperature Range Industrial (C Version) | -40°C to +125°C |
| Storage Temperature Range | -65°C to +125°C |
| Maximum Junction Temperature | 150°C |
| LFCSP θ_{JA} Thermal Impedance (Paddle Soldered) | 30.4°C/W |
| Reflow Soldering | |
| Peak Temperature | 260°C |
| Time at Peak Temperature | 40 sec |

Stresses at or above those listed under Absolute Maximum Ratings may cause permanent damage to the product. This is a stress rating only; functional operation of the product at these or any other conditions above those indicated in the operational section of this specification is not implied. Operation beyond the maximum operating conditions for extended periods may affect product reliability.

ESD CAUTION



ESD (electrostatic discharge) sensitive device. Charged devices and circuit boards can discharge without detection. Although this product features patented or proprietary protection circuitry, damage may occur on devices subjected to high energy ESD. Therefore, proper ESD precautions should be taken to avoid performance degradation or loss of functionality.

PIN CONFIGURATION AND PIN FUNCTION DESCRIPTIONS

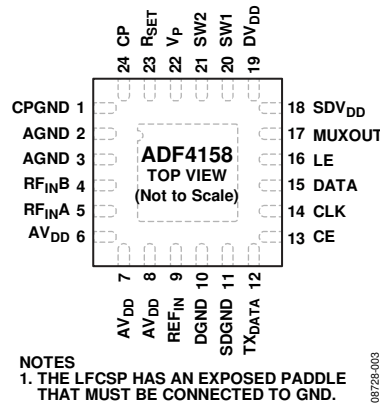

Figure 5. Pin Configuration

Table 5. Pin Function Descriptions

| Pin No. | Mnemonic | Description |
|---------|--------------------|--|
| 1 | CPGND | Charge Pump Ground. This is the ground return path for the charge pump. |
| 2, 3 | AGND | Analog Ground. This is the ground return path of the prescaler. |
| 4 | RF _{INB} | Complementary Input to the RF Prescaler. Decouple this point to the ground plane with a small bypass capacitor, typically 100 pF. |
| 5 | RF _{INA} | Input to the RF Prescaler. This small signal input is normally ac-coupled from the VCO. |
| 6, 7, 8 | AV _{DD} | Positive Power Supply for the RF Section. Place decoupling capacitors to the digital ground plane as close as possible to this pin. AV _{DD} must have the same voltage as DV _{DD} . |
| 9 | REF _{IN} | Reference Input. This is a CMOS input with a nominal threshold of V _{DD} /2 and an equivalent input resistance of 100 kΩ. It can be driven from a TTL or CMOS crystal oscillator, or it can be ac-coupled. |
| 10 | DGND | Digital Ground. |
| 11 | SDGND | Digital Σ-Δ Modulator Ground. Ground return path for the Σ-Δ modulator. |
| 12 | TX _{DATA} | Tx Data Pin. Provide data to be transmitted in FSK or PSK mode on this pin. |
| 13 | CE | Chip Enable. A logic low on this pin powers down the device and puts the charge pump output into three-state mode. |
| 14 | CLK | Serial Clock Input. This serial clock is used to clock in the serial data to the registers. The data is latched into the shift register on the CLK rising edge. This input is a high impedance CMOS input. |
| 15 | DATA | Serial Data Input. The serial data is loaded MSB first with the three LSBs being the control bits. This input is a high impedance CMOS input. |
| 16 | LE | Load Enable, CMOS Input. When LE is high, the data stored in the shift registers is loaded into one of the eight latches, with the latch being selected using the control bits. |
| 17 | MUXOUT | Multiplexer Output. This pin allows either the RF lock detect, the scaled RF, or the scaled reference frequency to be accessed externally. |
| 18 | SDV _{DD} | Power Supply Pin for the Digital Σ-Δ Modulator. This pin should be the same voltage as AV _{DD} . Place decoupling capacitors to the ground plane as close as possible to this pin. |
| 19 | DV _{DD} | Positive Power Supply for the Digital Section. Place decoupling capacitors to the digital ground plane as close as possible to this pin. DV _{DD} must have the same voltage as AV _{DD} . |
| 20, 21 | SW1, SW2 | Switches for Fast Lock. |
| 22 | V _P | Charge Pump Power Supply. This should be greater than or equal to V _{DD} . In systems where V _{DD} is 3 V, it can be set to 5.5 V and used to drive a VCO with a tuning range of up to 5.5 V. |
| 23 | R _{SET} | Connecting a resistor between this pin and ground sets the maximum charge pump output current. The relationship between I _{CP} and R _{SET} is $I_{CPmax} = \frac{25.5}{R_{SET}}$ where: I _{CPmax} = 5 mA. R _{SET} = 5.1 kΩ. |
| 24 | CP | Charge Pump Output. When enabled, this provides ±I _{CP} to the external loop filter, which in turn drives the external VCO. |
| 25 | EPAD | Exposed Paddle. The LFCSP has an exposed paddle that must be connected to GND. |

TYPICAL PERFORMANCE CHARACTERISTICS

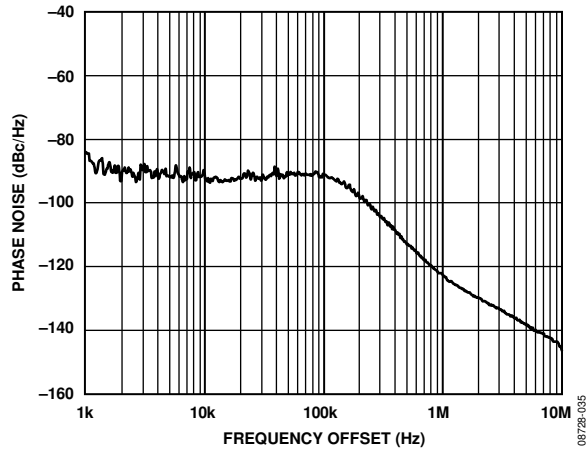

Figure 6. Phase Noise at 5805 MHz, PFD = 32 MHz, Loop Bandwidth = 100 kHz

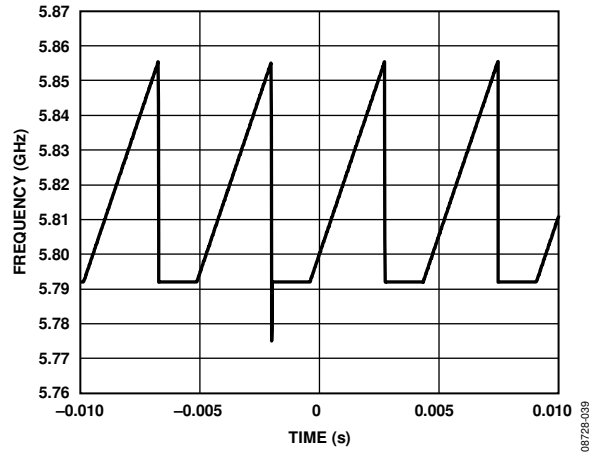

Figure 9. Delay Between Ramps for Sawtooth Waveform, PFD = 32 MHz, INT = 181, FRAC = 0, DEV Offset = 4, DEV Word = 20972, Step Word = 200, CLK₂ Divider = 10, CLK₁ Divider = 125, DEL Start Word = 1025

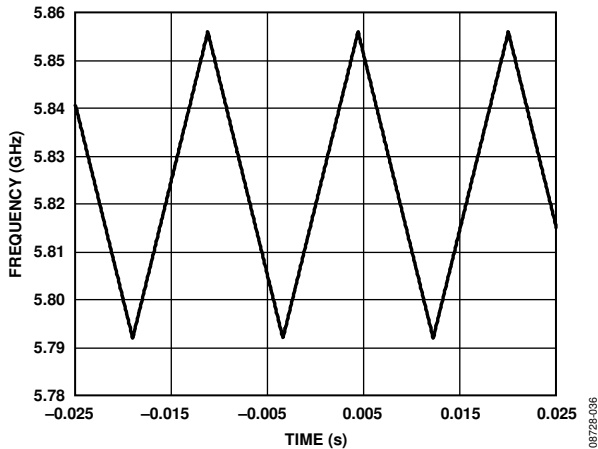

Figure 7. Triangular Waveform, PFD = 32 MHz, INT = 181, FRAC = 0, DEV Offset = 4, DEV Word = 20972, Step Word = 200, CLK₂ Divider = 10, CLK₁ Divider = 125

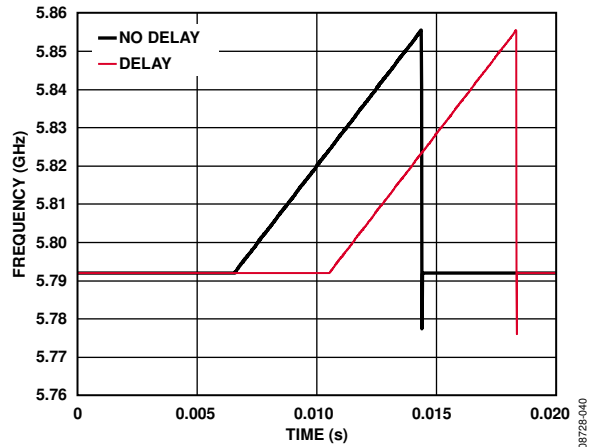

Figure 10. Delayed Start of Triangular Burst, PFD = 32 MHz, INT = 181, FRAC = 0, DEV Offset = 4, DEV Word = 20972, Step Word = 200, CLK₂ Divider = 10, CLK₁ Divider = 125, DEL Start Word = 1000

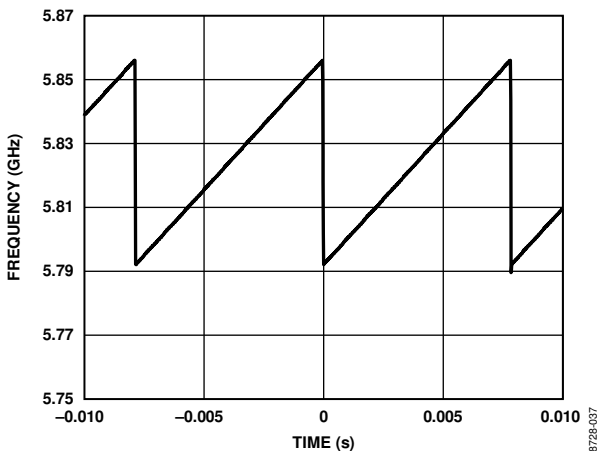

Figure 8. Sawtooth Waveform, PFD = 32 MHz, INT = 181, FRAC = 0, DEV Offset = 4, DEV Word = 20972, Step Word = 200, CLK₂ Divider = 10, CLK₁ Divider = 125

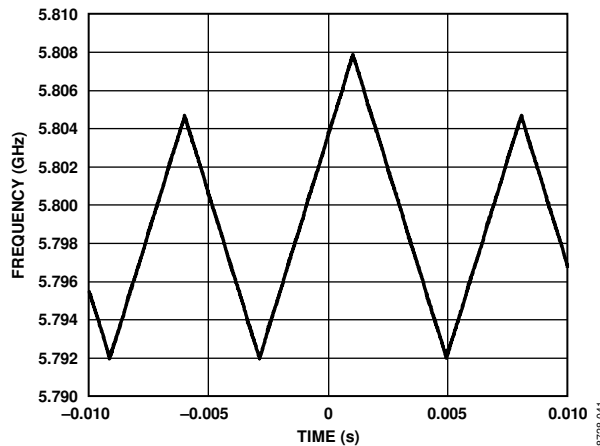

Figure 11. Dual Ramp Rate Waveform, PFD = 32 MHz, INT = 181, FRAC = 0, Ramp 1: DEV Offset = 3, DEV Word = 16777, Step Word = 100, Ramp 2: DEV Offset = 3, DEV Word = 20792, Step Word = 80

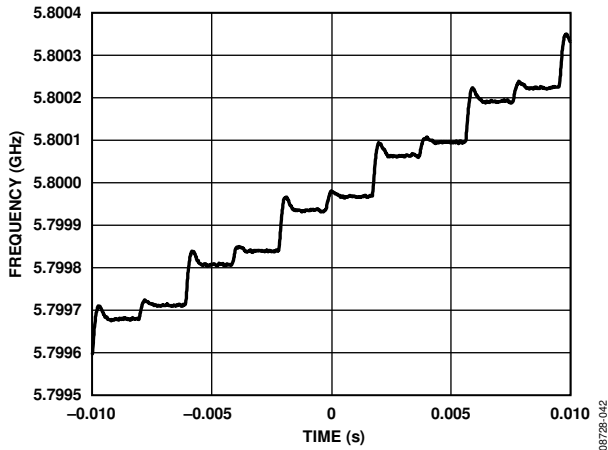

Figure 12. FSK Superimposed on Rising Edge of Triangular Waveform; Ramp Settings: PFD = 32 MHz, INT = 181, FRAC = 0, DEV Offset = 4, DEV Word = 20972, Step Word = 200, CLK DIV = 10, CLK Divider = 125; FSK Settings: DEV Offset = 3, DEV Word = 4194

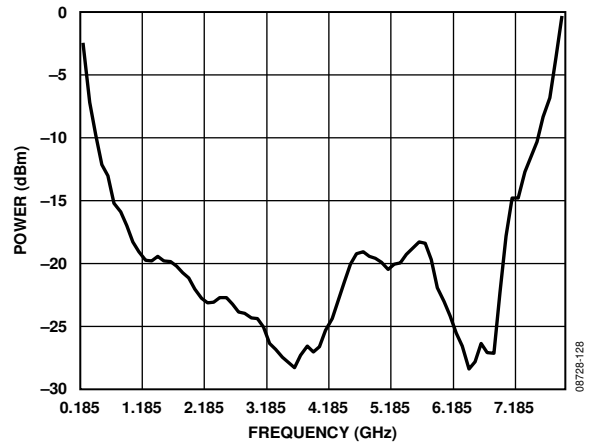

Figure 14. RF_{IN} Sensitivity-Average Over Temperature and V_{DD}

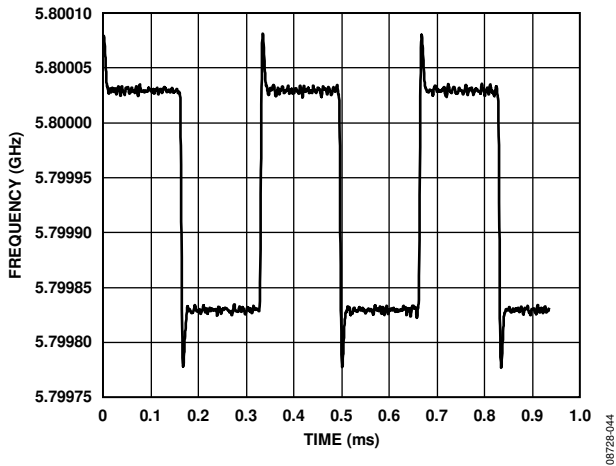

Figure 13. FSK; Settings: Frequency Deviation = 100 kHz, Data Rate = 3 kHz

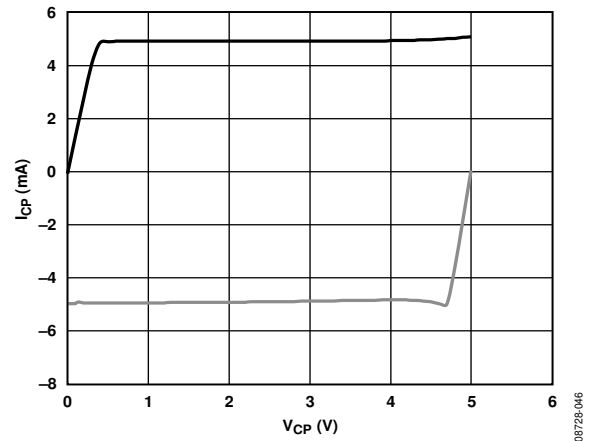

Figure 15. Charge Pump Output Characteristics

CIRCUIT DESCRIPTION

REFERENCE INPUT SECTION

The reference input stage is shown in Figure 16. SW1 and SW2 are normally closed switches. SW3 is normally open. When power-down is initiated, SW3 is closed and SW1 and SW2 are opened. This ensures that there is no loading of the REF_{IN} pin on power-down.

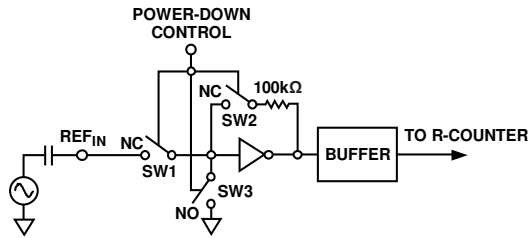

Figure 16. Reference Input Stage

RF INPUT STAGE

The RF input stage is shown in Figure 17. It is followed by a 2-stage limiting amplifier to generate the current-mode logic (CML) clock levels needed for the prescaler.

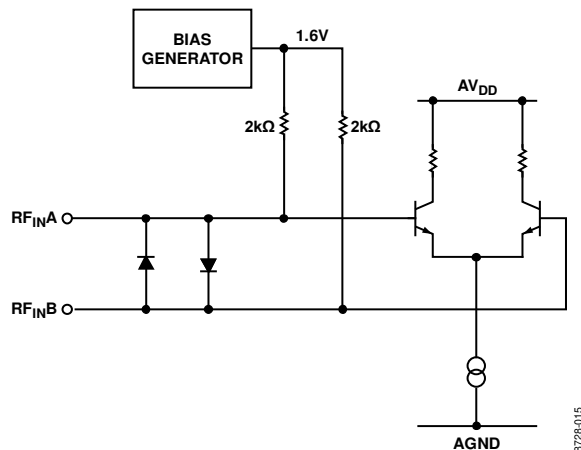

Figure 17. RF Input Stage

RF INT DIVIDER

The RF INT CMOS counter allows a division ratio in the PLL feedback counter. Division ratios from 23 to 4095 are allowed.

25-BIT FIXED MODULUS

The ADF4158 has a 25-bit fixed modulus. This allows output frequencies to be spaced with a resolution of

$$f_{RES} = f_{PFD} / 2^{25} \quad (1)$$

where f_{PFD} is the frequency of the phase frequency detector (PFD). For example, with a PFD frequency of 10 MHz, frequency steps of 0.298 Hz are possible. Due to the architecture of the Σ - Δ modulator, there is a fixed $+ (f_{PFD} / 2^{26})$ offset on the VCO output. To remove this offset, see the Σ - Δ Modulator Mode section.

INT, FRAC, AND R RELATIONSHIP

The INT and FRAC values, in conjunction with the R-counter, make it possible to generate output frequencies that are spaced by fractions of the phase frequency detector (PFD). The RF VCO frequency (RF_{OUT}) equation is

$$RF_{OUT} = f_{PFD} \times (INT + (FRAC / 2^{25})) \quad (2)$$

where:

RF_{OUT} is the output frequency of external voltage controlled oscillator (VCO).

INT is the preset divide ratio of binary 12-bit counter (23 to 4095).

FRAC is the numerator of the fractional division (0 to $2^{25} - 1$).

$$f_{PFD} = REF_{IN} \times [(1 + D) / (R \times (1 + T))] \quad (3)$$

where:

REF_{IN} is the reference input frequency.

D is the REF_{IN} doubler bit (0 or 1).

R is the preset divide ratio of the binary, 5-bit, programmable reference counter (1 to 32).

T is the REF_{IN} divide-by-2 bit (0 or 1).

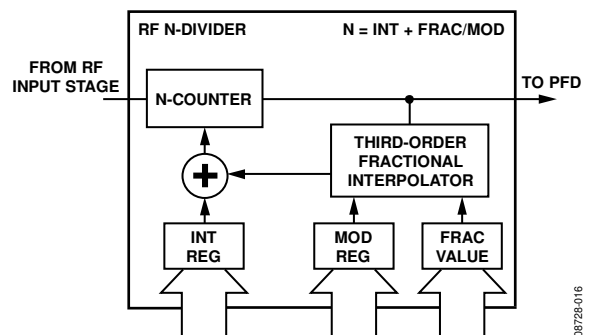

Figure 18. RF N-Divider

R-COUNTER

The 5-bit R-counter allows the input reference frequency (REF_{IN}) to be divided down to produce the reference clock to the PFD. Division ratios from 1 to 32 are allowed.

PHASE FREQUENCY DETECTOR (PFD) AND CHARGE PUMP

The PFD takes inputs from the R-counter and N-counter and produces an output proportional to the phase and frequency difference between them. Figure 19 shows a simplified schematic of the PFD. The PFD includes a fixed delay element that sets the width of the antibacklash pulse, which is typically 3 ns. This pulse ensures that there is no dead zone in the PFD transfer function and gives a consistent reference spur level.

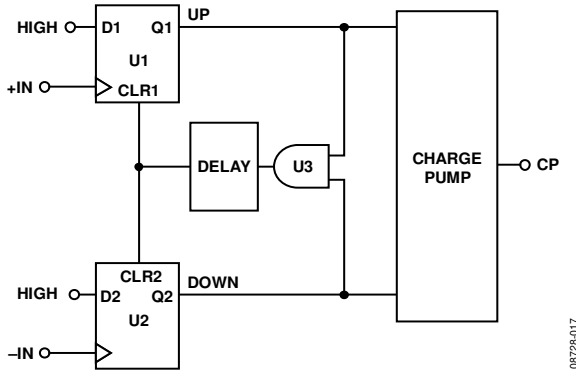

Figure 19. PFD Simplified Schematic

MUXOUT AND LOCK DETECT

The output multiplexer on the ADF4158 allows the user to access various internal points on the chip. The state of MUXOUT is controlled by the M4, M3, M2, and M1 bits (see Figure 23). Figure 20 shows the MUXOUT section in block diagram form.

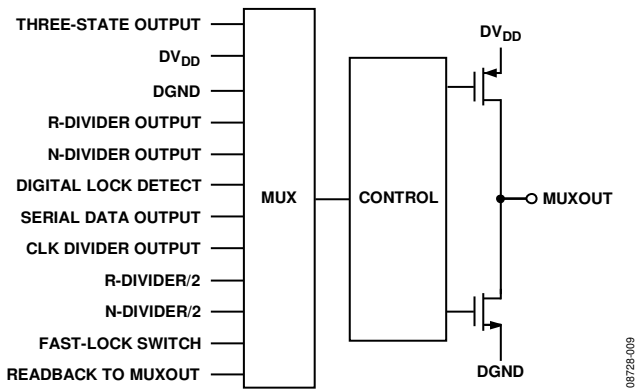

Figure 20. MUXOUT Schematic

INPUT SHIFT REGISTERS

The ADF4158 digital section includes a 5-bit RF R-counter, a 12-bit RF N-counter, and a 25-bit FRAC counter. Data is clocked into the 32-bit shift register on each rising edge of CLK. The data is clocked in MSB first. Data is transferred from the shift register to one of eight latches on the rising edge of LE. The destination latch is determined by the state of the three control bits (C3, C2, and C1) in the shift register. These are the three LSBs—DB2, DB1, and DB0—as shown in Figure 2. The truth table for these bits is shown in Table 6. Figure 21 and Figure 22 show a summary of how the latches are programmed.

PROGRAM MODES

Table 6 and Figure 23 through Figure 30 show how to set up the program modes in the ADF4158.

Several settings in the ADF4158 are double buffered. These include the LSB fractional value, R-counter value, reference doubler, current setting, and RDIV2. This means that two events must occur before the part uses a new value for any of the double-buffered settings. First, the new value is latched into the device by writing to the appropriate register. Second, a new write must be performed on Register R0.

For example, updating the fractional value can involve a write to the 13 LSB bits in R1 and the 12 MSB bits in R0. R1 should be written to first, followed by the write to R0. The frequency change begins after the write to R0. Double buffering ensures that the bits written to in R1 do not take effect until after the write to R0.

Table 6. C3, C2, and C1 Truth Table

| Control Bits | | | Register |
|--------------|----|----|----------|
| C3 | C2 | C1 | |
| 0 | 0 | 0 | R0 |
| 0 | 0 | 1 | R1 |
| 0 | 1 | 0 | R2 |
| 0 | 1 | 1 | R3 |
| 1 | 0 | 0 | R4 |
| 1 | 0 | 1 | R5 |
| 1 | 1 | 0 | R6 |
| 1 | 1 | 1 | R7 |

REGISTER MAPS

FRAC/INT REGISTER (R0)

| RAMP ON | MUXOUT CONTROL | | | | | 12-BIT INTEGER VALUE (INT) | | | | | | | | | | | 12-BIT MSB FRACTIONAL VALUE (FRAC) | | | | | | | | CONTROL BITS | | | | | | |
|---------|----------------|------|------|------|------|----------------------------|------|------|------|------|------|------|------|------|------|------|------------------------------------|------|------|------|------|------|-----|-----|--------------|-----|-----|-----|-------|-------|-------|
| | DB31 | DB30 | DB29 | DB28 | DB27 | DB26 | DB25 | DB24 | DB23 | DB22 | DB21 | DB20 | DB19 | DB18 | DB17 | DB16 | DB15 | DB14 | DB13 | DB12 | DB11 | DB10 | DB9 | DB8 | DB7 | DB6 | DB5 | DB4 | DB3 | DB2 | DB1 |
| R1 | M4 | M3 | M2 | M1 | N12 | N11 | N10 | N9 | N8 | N7 | N6 | N5 | N4 | N3 | N2 | N1 | F25 | F24 | F23 | F22 | F21 | F20 | F19 | F18 | F17 | F16 | F15 | F14 | C3(0) | C2(0) | C1(0) |

LSB FRAC REGISTER (R1)

| RESERVED | | | | | 13-BIT LSB FRACTIONAL VALUE (FRAC) (DBB) | | | | | | | | | | | RESERVED | | | | | | | | CONTROL BITS | | | | | | | |
|----------|------|------|------|------|--|------|------|------|------|------|------|------|------|------|------|----------|------|------|------|------|------|-----|-----|--------------|-----|-----|-----|-----|-------|-------|-------|
| DB31 | DB30 | DB29 | DB28 | DB27 | DB26 | DB25 | DB24 | DB23 | DB22 | DB21 | DB20 | DB19 | DB18 | DB17 | DB16 | DB15 | DB14 | DB13 | DB12 | DB11 | DB10 | DB9 | DB8 | DB7 | DB6 | DB5 | DB4 | DB3 | DB2 | DB1 | DB0 |
| 0 | 0 | 0 | 0 | F13 | F12 | F11 | F10 | F9 | F8 | F7 | F6 | F5 | F4 | F3 | F2 | F1 | 0 | 0 | 0 | 0 | 0 | 0 | 0 | 0 | 0 | 0 | 0 | 0 | C3(0) | C2(0) | C1(0) |

R-DIVIDER REGISTER (R2)

| RESERVED | CSR EN | DBB | | | | | RESERVED | PRESCALER | R DIV2 DBB | REFERENCE DOUBLER DBB | DBB | | | | | 12-BIT CLK ₁ DIVIDER | | | | | | | | CONTROL BITS | | | | | | | | | | | | | | | | | |
|----------|--------|--------------------|-----|------|------|------|----------|-----------|------------|-----------------------|-----------------|----|----|----|----|---------------------------------|------|------|------|------|------|------|------|--------------|------|------|------|------|-------|-------|-------|------|------|------|------|------|------|-----|-----|-----|-----|
| | | CP CURRENT SETTING | | | | | | | | | 5-BIT R-COUNTER | | | | | DB31 | DB30 | DB29 | DB28 | DB27 | DB26 | DB25 | DB24 | DB23 | DB22 | DB21 | DB20 | DB19 | DB18 | DB17 | DB16 | DB15 | DB14 | DB13 | DB12 | DB11 | DB10 | DB9 | DB8 | DB7 | DB6 |
| 0 | 0 | 0 | CR1 | CPI4 | CPI3 | CPI2 | CPI1 | 0 | P1 | U2 | U1 | R5 | R4 | R3 | R2 | R1 | D12 | D11 | D10 | D9 | D8 | D7 | D6 | D5 | D4 | D3 | D2 | D1 | C3(0) | C2(1) | C1(0) | | | | | | | | | | |

FUNCTION REGISTER (R3)

| RESERVED | | | | | | | | | | | | | | | | N SEL | SD RESET | RESERVED | RAMP MODE | PSK ENABLE | FSK ENABLE | LDP | PD POLARITY | POWER-DOWN | CP THREE-STATE COUNTER RESET | CONTROL BITS | | | | | |
|----------|------|------|------|------|------|------|------|------|------|------|------|------|------|------|------|-------|----------|----------|-----------|------------|------------|-----|-------------|------------|------------------------------|--------------|------|------|-------|-------|-------|
| DB31 | DB30 | DB29 | DB28 | DB27 | DB26 | DB25 | DB24 | DB23 | DB22 | DB21 | DB20 | DB19 | DB18 | DB17 | DB16 | | | | | | | | | | | DB15 | DB14 | DB13 | DB12 | DB11 | DB10 |
| 0 | 0 | 0 | 0 | 0 | 0 | 0 | 0 | 0 | 0 | 0 | 0 | 0 | 0 | 0 | 0 | NS1 | U12 | 0 | 0 | RM2 | RM1 | PE1 | FE1 | U11 | U10 | U9 | U8 | U7 | C3(0) | C2(1) | C1(1) |

NOTES
1. DBB = DOUBLE-BUFFERED BIT(S).

Figure 21. Register Summary 1

08728-010

TEST REGISTER (R4)

| LE SEL | Σ-Δ MODULATOR MODE | | | | | | RESERVED | NEG BLEED CURRENT | READ-BACK TO MUXOUT | CLK DIV MODE | 12-BIT CLK ₂ DIVIDER VALUE | | | | | | | | | | | | RESERVED | | | | CONTROL BITS | | | | |
|--------|--------------------|------|------|------|------|------|----------|-------------------|---------------------|--------------|---------------------------------------|------|------|------|------|------|------|------|------|------|------|------|----------|-----|-----|-----|--------------|-----|-------|-------|-------|
| | DB31 | DB30 | DB29 | DB28 | DB27 | DB26 | DB25 | DB24 | DB23 | DB22 | DB21 | DB20 | DB19 | DB18 | DB17 | DB16 | DB15 | DB14 | DB13 | DB12 | DB11 | DB10 | DB9 | DB8 | DB7 | DB6 | DB5 | DB4 | DB3 | DB2 | DB1 |
| LS1 | S5 | S4 | S3 | S2 | S1 | 0 | NB2 | NB1 | R2 | R1 | C2 | C1 | D12 | D11 | D10 | D9 | D8 | D7 | D6 | D5 | D4 | D3 | D2 | D1 | 0 | 0 | 0 | 0 | C3(1) | C2(0) | C1(0) |

DEVIATION REGISTER (R5)

| RESERVED | TX RAMP CLK | PAR RAMP | INTERRUPT | FSK RAMP EN | RAMP 2 EN | DEV SEL | 4-BIT DEV OFFSET WORD | | | | 16-BIT DEVIATION WORD | | | | | | | | | | | | | | | | CONTROL BITS | | | | |
|----------|-------------|----------|-----------|-------------|-----------|---------|-----------------------|------|------|------|-----------------------|------|------|------|------|------|------|------|------|------|------|-----|-----|-----|-----|-----|--------------|-----|-------|-------|-------|
| DB31 | DB30 | DB29 | DB28 | DB27 | DB26 | DB25 | DB24 | DB23 | DB22 | DB21 | DB20 | DB19 | DB18 | DB17 | DB16 | DB15 | DB14 | DB13 | DB12 | DB11 | DB10 | DB9 | DB8 | DB7 | DB6 | DB5 | DB4 | DB3 | DB2 | DB1 | DB0 |
| 0 | 0 | TR1 | PR1 | I2 | I1 | FRE1 | R2E1 | DS1 | DO4 | DO3 | DO2 | DO1 | D16 | D15 | D14 | D13 | D12 | D11 | D10 | D9 | D8 | D7 | D6 | D5 | D4 | D3 | D2 | D1 | C3(1) | C2(0) | C1(1) |

STEP REGISTER (R6)

| RESERVED | | | | | | | | STEP SEL | 20-BIT STEP WORD | | | | | | | | | | | | | | | | | | | CONTROL BITS | | | |
|----------|------|------|------|------|------|------|------|----------|------------------|------|------|------|------|------|------|------|------|------|------|------|------|-----|-----|-----|-----|-----|-----|--------------|-------|-------|-------|
| DB31 | DB30 | DB29 | DB28 | DB27 | DB26 | DB25 | DB24 | DB23 | DB22 | DB21 | DB20 | DB19 | DB18 | DB17 | DB16 | DB15 | DB14 | DB13 | DB12 | DB11 | DB10 | DB9 | DB8 | DB7 | DB6 | DB5 | DB4 | DB3 | DB2 | DB1 | DB0 |
| 0 | 0 | 0 | 0 | 0 | 0 | 0 | 0 | SSE1 | S20 | S19 | S18 | S17 | S16 | S15 | S14 | S13 | S12 | S11 | S10 | S9 | S8 | S7 | S6 | S5 | S4 | S3 | S2 | S1 | C3(1) | C2(1) | C1(0) |

DELAY REGISTER (R7)

| RESERVED | | | | | | | | | | | | | RAMP DEL FL | RAMP DEL | DEL CLK SEL | DEL START EN | 12-BIT DELAY START DIVIDER | | | | | | | | | | | | CONTROL BITS | | |
|----------|------|------|------|------|------|------|------|------|------|------|------|------|-------------|----------|-------------|--------------|----------------------------|------|------|------|------|-----|-----|-----|-----|-----|-----|-----|--------------|-------|-------|
| DB31 | DB30 | DB29 | DB28 | DB27 | DB26 | DB25 | DB24 | DB23 | DB22 | DB21 | DB20 | DB19 | DB18 | DB17 | DB16 | DB15 | DB14 | DB13 | DB12 | DB11 | DB10 | DB9 | DB8 | DB7 | DB6 | DB5 | DB4 | DB3 | DB2 | DB1 | DB0 |
| 0 | 0 | 0 | 0 | 0 | 0 | 0 | 0 | 0 | 0 | 0 | 0 | 0 | RDF1 | RD1 | DC1 | DSE1 | DS12 | DS11 | DS10 | DS9 | DS8 | DS7 | DS6 | DS5 | DS4 | DS3 | DS2 | DS1 | C3(1) | C2(1) | C1(1) |

Figure 22. Register Summary 2

08728-110

FRAC/INT REGISTER (R0) MAP

With Register R0 DB[2:0] set to [0, 0, 0], the on-chip FRAC/INT register is programmed as shown in Figure 23.

Ramp On

Setting DB31 to 1 enables the ramp, setting DB31 to 0 disables the ramp.

MUXOUT Control

The on-chip multiplexer is controlled by DB[30:27] on the ADF4158. See Figure 23 for the truth table.

12-Bit Integer Value (INT)

These 12 bits control what is loaded as the INT value. This is used to determine the overall feedback division factor. It is used in Equation 2. See the INT, FRAC, and R Relationship section for more information.

12-Bit MSB Fractional Value (FRAC)

These 12 bits, along with Bits DB[27:15] in the LSB FRAC register (Register R1), control what is loaded as the FRAC value into the fractional interpolator. This is part of what determines the overall feedback division factor. It is also used in Equation 2. These 12 bits are the most significant bits (MSB) of the 25-bit FRAC value, and Bits DB[27:15] in the LSB FRAC register (Register R1) are the least significant bits (LSB). See the RF Synthesizer: A Worked Example section for more information.

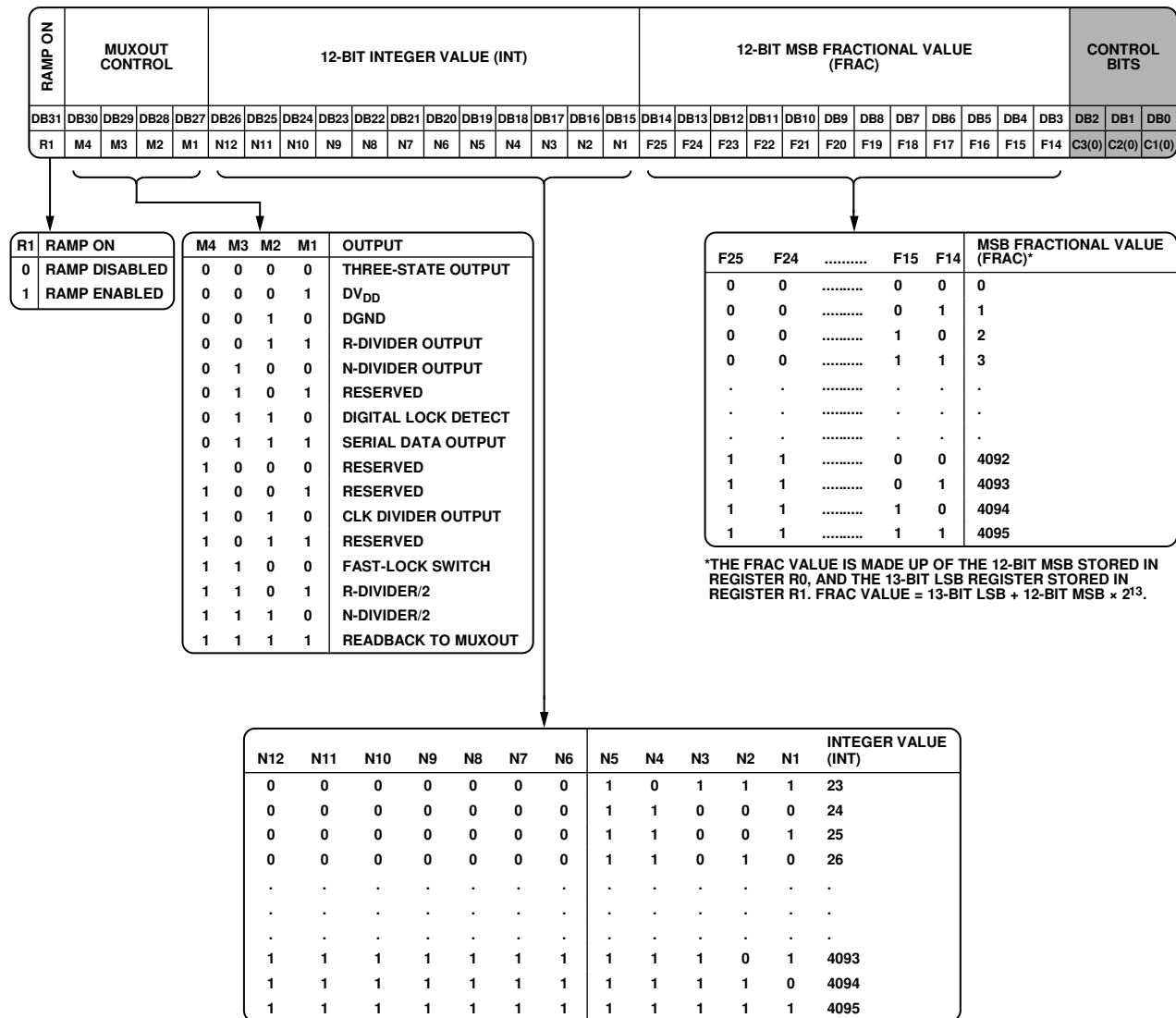

*THE FRAC VALUE IS MADE UP OF THE 12-BIT MSB STORED IN REGISTER R0, AND THE 13-BIT LSB REGISTER STORED IN REGISTER R1. FRAC VALUE = 13-BIT LSB + 12-BIT MSB × 2¹³.

Figure 23. FRAC/INT Register (R0) Map

LSB FRAC REGISTER (R1) MAP

With Register R1 DB[2:0] set to [0, 0, 1], the on-chip LSB FRAC register is programmed as shown in Figure 24.

13-Bit LSB FRAC Value

These 13 bits, along with Bits DB[14:3] in the FRAC/INT register (Register R0), control what is loaded as the FRAC value into the fractional interpolator. This is part of what determines the overall feedback division factor. It is also used in Equation 2. These 13 bits

are the least significant bits (LSB) of the 25-bit FRAC value, and Bits DB[14:3] in the INT/FRAC register are the most significant bits (MSB). See the RF Synthesizer: A Worked Example section for more information.

Reserved Bits

All reserved bits should be set to 0 for normal operation.

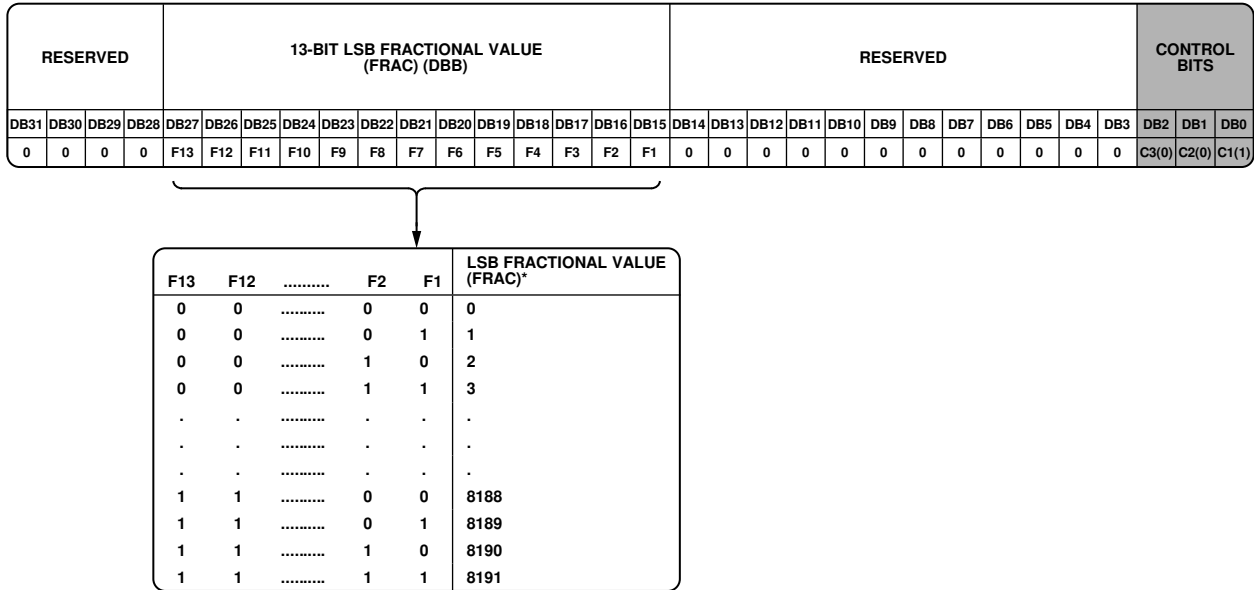

*THE FRAC VALUE IS MADE UP OF THE 12-BIT MSB STORED IN REGISTER R0, AND THE 13-BIT LSB REGISTER STORED IN REGISTER R1. FRAC VALUE = 13-BIT LSB + 12-BIT MSB x 2¹³.

- NOTES
1. DBB = DOUBLE-BUFFERED BITS.

Figure 24. LSB FRAC Register (R1) Map

08728-012

R-DIVIDER REGISTER (R2) MAP

With Register R2 DB[2:0] set to [0, 1, 0], the on-chip R-divider register is programmed as shown in Figure 25.

Reserved Bits

All reserved bits should be set to 0 for normal operation.

CSR Enable

Setting this bit to 1 enables cycle slip reduction. This is a method for improving lock times. Note that the signal at the PFD must have a 50% duty cycle in order for cycle slip reduction to work. In addition, the charge pump current setting must be set to a minimum. See the Cycle Slip Reduction for Faster Lock Times section for more information.

Also note that the cycle slip reduction feature can only be operated when the phase detector polarity setting is positive (DB6 in Register R3). It cannot be used if the phase detector polarity is set to negative.

Charge Pump Current Setting

DB[27:24] set the charge pump current setting (see Figure 25). Set these bits to the charge pump current that the loop filter is designed with.

Prescaler (P/P + 1)

The dual-modulus prescaler ($P/P + 1$), along with the INT, FRAC, and MOD counters, determines the overall division ratio from the R_{FIN} to the PFD input.

Operating at CML levels, it takes the clock from the RF input stage and divides it down for the counters. It is based on a synchronous 4/5 core. When set to 4/5, the maximum RF frequency allowed is 3 GHz. Therefore, when operating the ADF4158 above 3 GHz, the prescaler must be set to 8/9. The prescaler limits the INT value.

With $P = 4/5$, $N_{MIN} = 23$.

With $P = 8/9$, $N_{MIN} = 75$.

RDIV2

Setting DB21 to 1 inserts a divide-by-2 toggle flip-flop between the R-counter and the PFD. This can be used to provide a 50% duty cycle signal at the PFD for use with cycle slip reduction.

Reference Doubler

Setting DB20 to 0 feeds the REF_{IN} signal directly to the 5-bit RF R-counter, disabling the doubler. Setting this bit to 1 multiplies the REF_{IN} frequency by a factor of 2 before feeding the signal into the 5-bit R-counter. When the doubler is disabled, the REF_{IN} falling edge is the active edge at the PFD input to the fractional synthesizer. When the doubler is enabled, both the rising edge and falling edge of REF_{IN} become active edges at the PFD input.

The maximum allowed REF_{IN} frequency when the doubler is enabled is 30 MHz.

5-Bit R-Counter

The 5-bit R-counter allows the input reference frequency (REF_{IN}) to be divided down to produce the reference clock to the phase frequency detector (PFD). Division ratios from 1 to 32 are allowed.

12-Bit CLK_1 Divider

Bits DB[14:3] are used to program the CLK_1 divider, which determines the duration of the time step in ramp mode.

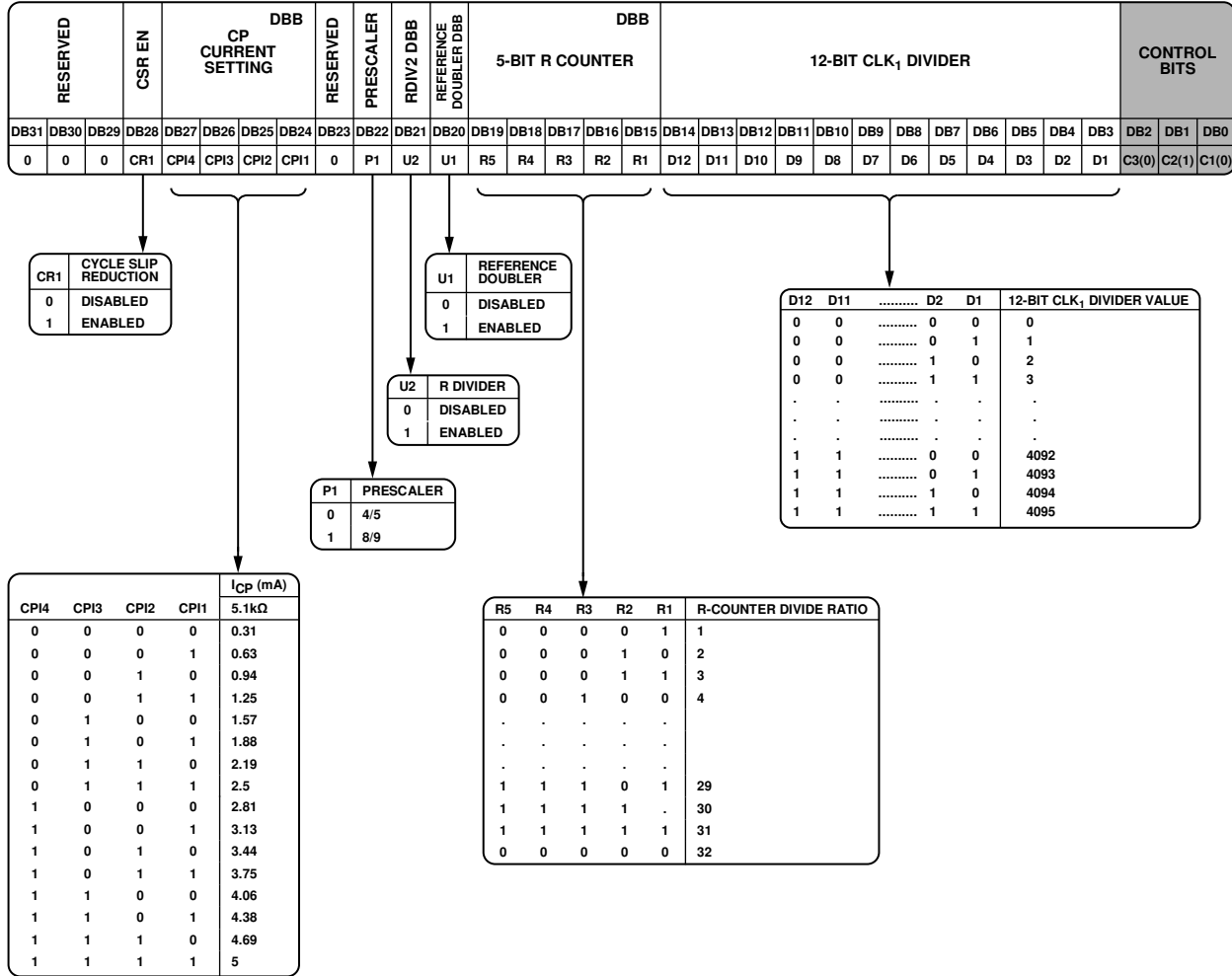

NOTES
1. DBB = DOUBLE-BUFFERED BITS.

Figure 25. R-Divider Register (R2) Map

08728-013

FUNCTION REGISTER (R3) MAP

With Register R3 DB[2:0] set to [0, 1, 1], the on-chip function register is programmed as shown in Figure 26.

Reserved Bits

All reserved bits should be set to 0 for normal operation.

N SEL

This setting is used to circumvent the issue of pipeline delay between an update of the integer and fractional values in the N-counter. Typically, the INT value is loaded first, followed by the FRAC value. This can cause the N-counter value to be at an incorrect value for a brief period of time equal to the pipeline delay (about four PFD cycles). This has no effect if the INT value has not been updated. However, if the INT value has been changed, this can cause the PLL to overshoot in frequency while it tries to lock to the temporarily incorrect N value. After the correct fractional value is loaded, the PLL quickly locks to the correct frequency. Introducing an additional delay to the loading of the INT value using the N SEL bit causes the INT and FRAC values to be loaded at the same time, preventing frequency overshoot. The delay is turned on by setting Bit DB15 to 1.

SD Reset

For most applications, DB14 should be set to 0. When DB14 is set to 0, the Σ - Δ modulator is reset on each write to Register R0. If it is not required that the Σ - Δ modulator be reset on each Register R0 write, set this bit to 1.

Ramp Mode

DB[11:10] determine the type of generated waveform.

PSK Enable

When DB9 is set to 1, PSK modulation is enabled. When set to 0, PSK modulation is disabled.

FSK Enable

When DB8 is set to 1, FSK modulation is enabled. When set to 0, FSK modulation is disabled.

Lock Detect Precision (LDP)

When DB7 is programmed to 0, 24 consecutive PFD cycles of 15 ns must occur before digital lock detect is set. When this bit is programmed to 1, 40 consecutive reference cycles of 15 ns must occur before digital lock detect is set.

Phase Detector (PD) Polarity

DB6 sets the phase detector polarity. When the VCO characteristics are positive, set this bit to 1. When the VCO characteristics are negative, set this bit to 0.

Power-Down

DB5 provides the programmable power-down mode. Setting this bit to 1 performs a power-down. Setting this bit to 0 returns the synthesizer to normal operation. While in software power-down mode, the part retains all information in its registers. Only when supplies are removed are the register contents lost.

When a power-down is activated, the following events occur:

1. All active dc current paths are removed.
2. The synthesizer counters are forced to their load state conditions.
3. The charge pump is forced into three-state mode.
4. The digital lock-detect circuitry is reset.
5. The RF_{IN} input is debiased.
6. The input register remains active and capable of loading and latching data.

Charge Pump Three-State

DB4 puts the charge pump into three-state mode when programmed to 1. It should be set to 0 for normal operation.

Counter Reset

DB3 is the RF counter reset bit. When this bit is set to 1, the RF synthesizer counters are held in reset. For normal operation, set this bit to 0.

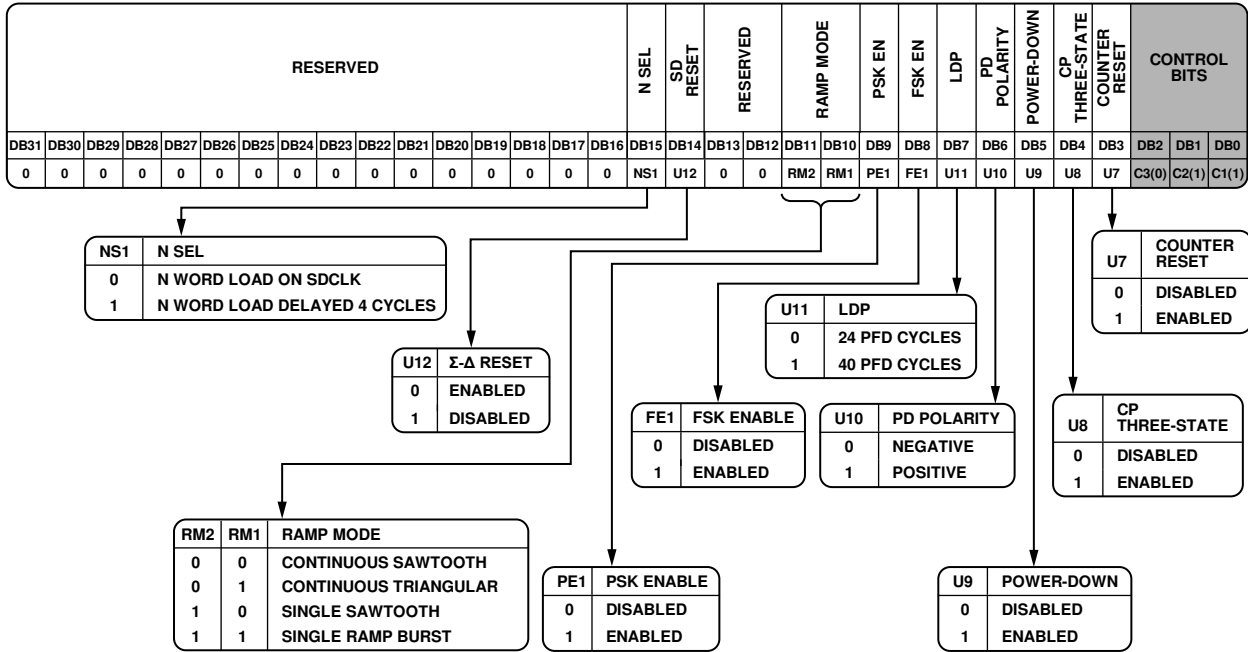

Figure 26. Function Register (R3) Map

08728-014

TEST REGISTER (R4) MAP

With Register R4 DB[2:0] set to [1, 0, 0], the on-chip test register (R4) is programmed as shown in Figure 27.

LE SEL

In some applications, it is necessary to synchronize LE with the reference signal. To do this, DB31 should be set to 1. Synchronization is done internally on the part.

Σ - Δ Modulator Mode

To completely disable the Σ - Δ modulator, set Bits DB[30:26] to 0b01110, which puts the ADF4158 into integer-N mode, and the channel spacing becomes equal to the PFD frequency. Both the 12-bit MSB fractional value (Register R0, DB[14:3]) and the 13-bit LSB fractional value (Register R1, DB[27:15]) must be set to 0. After writing to Register 4, Register 3 must be written to twice to trigger a counter reset. (That is, write Register 3 with DB3 = 1, and then write Register 3 with DB3 = 0.)

All features driven by the Σ - Δ modulator are disabled, such as ramping, PSK, FSK, and phase adjust.

Disabling the Σ - Δ modulator also removes the fixed + ($f_{PFD}/2^{26}$) offset on the VCO output.

For normal operation, set these bits to 0b00000.

Reserved Bits

All reserved bits should be set to 0 for normal operation.

Negative Bleed Current

Setting Bits DB[24:23] to 11 turns on the constant negative bleed current. This ensures that the charge pump operates out of the dead zone. Thus, the phase noise is not degraded and the level of spurs is lower. Enabling constant negative bleed current is particularly important on channels close to multiple PFD frequencies. Refer to the AN-1154 Application Note for more information on the negative bleed current. When using negative bleed current, readback to MUXOUT must be disabled.

Readback to MUXOUT

DB[22:21] enable or disable the readback to MUXOUT function. This function allows reading back the synthesizer’s frequency at the moment of interrupt. When using readback to MUXOUT, negative bleed current must be off.

Clock Divider (DIV) Mode

Bits DB[20:19] are used to enable ramp divider mode or fast lock divider mode. If neither is being used, set these bits to 0b00.

12-Bit CLK₂ Divider Value

Bits DB[18:7] program the clock divider (the CLK₂ timer) when the part operates in ramp mode (see the Timeout Interval section). The CLK₂ timer also determines how long the loop remains in wideband mode when fast lock mode is used (see the Fast Lock Mode section).

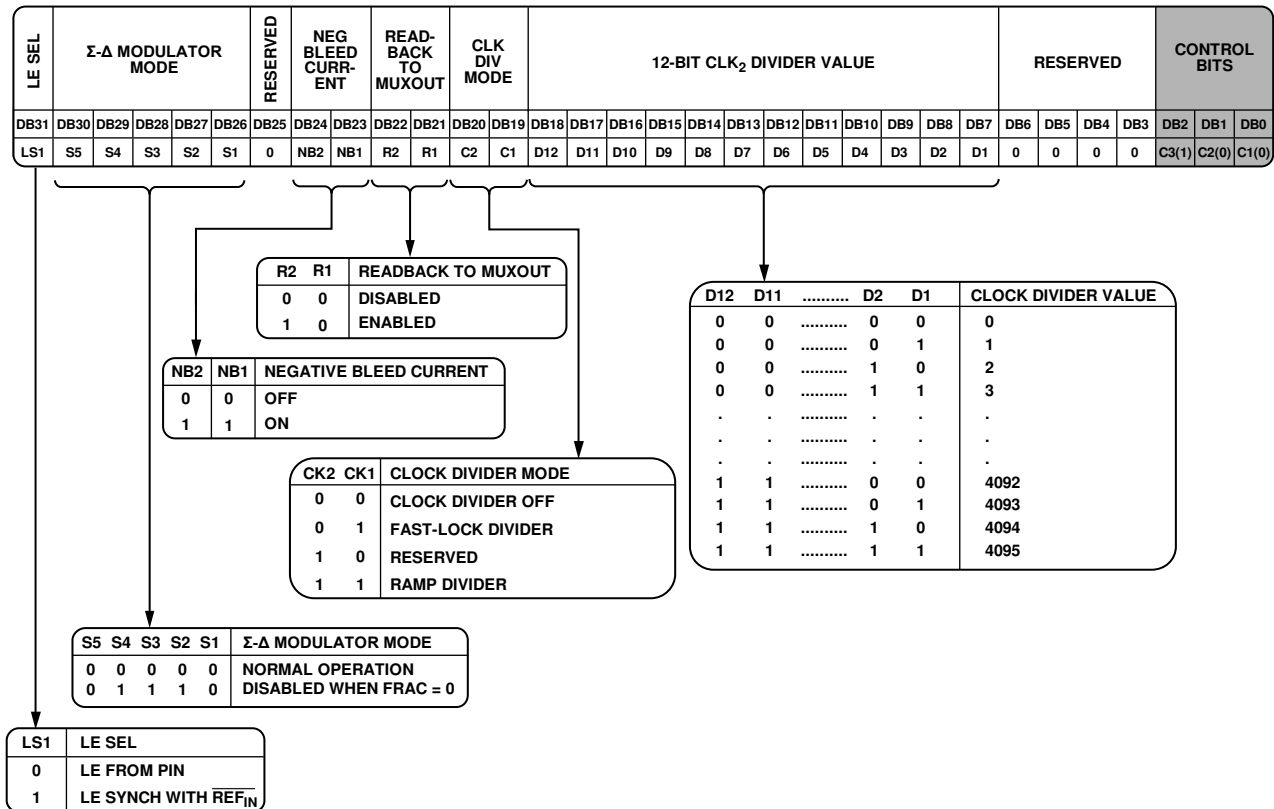

Figure 27. Test Register (R4) Map

DEVIATION REGISTER (R5) MAP

With Register R5 DB[2:0] set to [1, 0, 1], the on-chip deviation register is programmed as shown in Figure 28.

Reserved Bits

All reserved bits should be set to 0 for normal operation.

Tx Ramp CLK

Setting DB29 to 0 uses the clock divider clock for clocking the ramp. Setting DB29 to 1 uses the Tx data clock for clocking the ramp.

PAR Ramp

Setting DB28 to 1 enables the parabolic ramp. Setting DB28 to 0 disables the parabolic ramp.

Interrupt

DB[27:26] determine which type of interrupt is used. This feature is used for reading back the INT and FARC value of a ramp at a given moment in time (rising edge on the TX_{DATA} pin triggers the interrupt). From these bits, frequency can be obtained. After readback, the sweep might continue or stop at the readback frequency.

FSK Ramp Enable

Setting DB25 to 1 enables the FSK ramp. Setting DB25 to 0 disables the FSK ramp.

Ramp 2 Enable

Setting DB24 to 1 enables the second ramp. Setting DB24 to 0 disables the second ramp.

Deviation Select

Setting DB23 to 0 chooses the first deviation word. Setting DB23 to 1 chooses the second deviation word.

4-Bit Deviation Offset Word

DB[22:19] determine the deviation offset. The deviation offset affects the deviation resolution.

16-Bit Deviation Word

DB[18:3] determine the signed deviation word. The deviation word defines the deviation step.

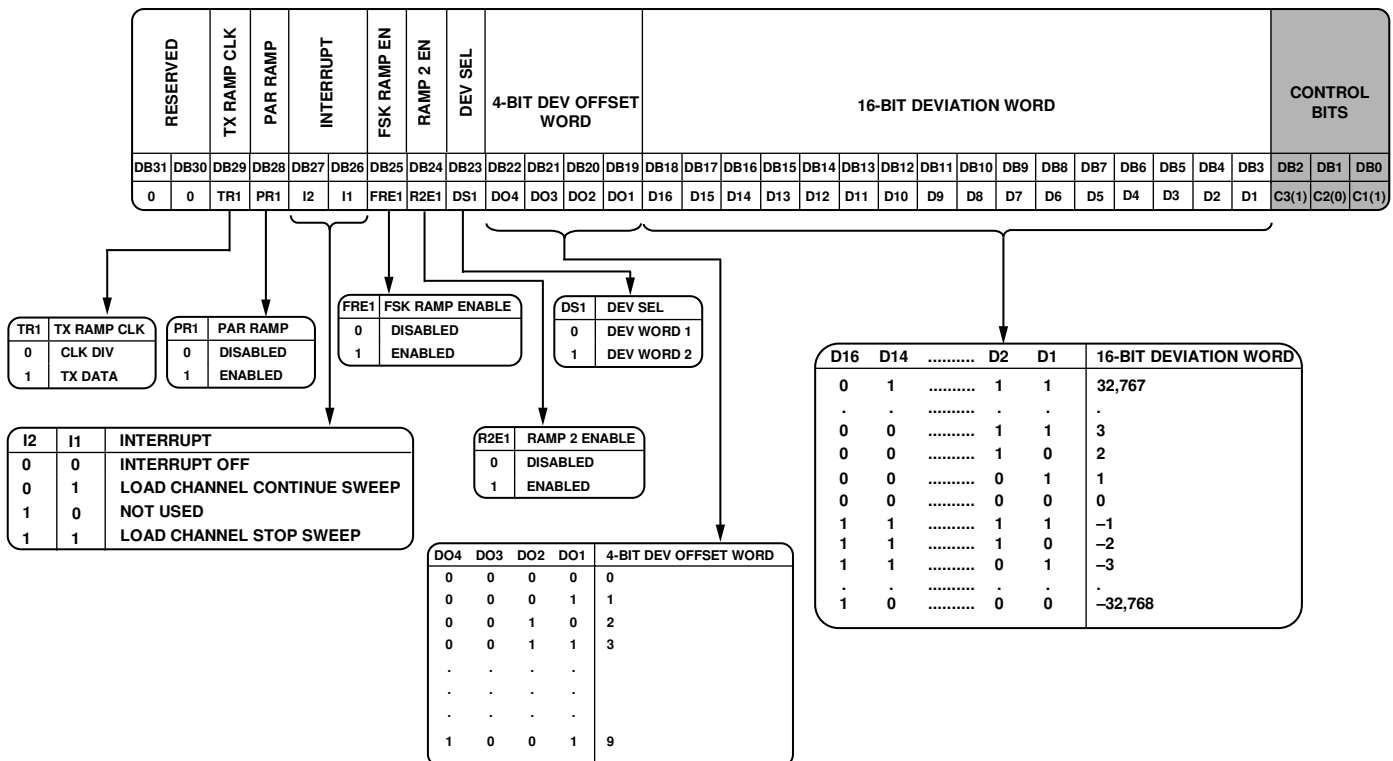

Figure 28. Deviation Register (R5) Map

07828-116

STEP REGISTER (R6) MAP

With Register R6 DB[2:0] set to [1, 1, 0], the on-chip step register is programmed as shown in Figure 29.

Reserved Bits

All reserved bits should be set to 0 for normal operation.

Step SEL

Setting DB23 to 0 chooses Step Word 1. Setting DB23 to 1 chooses Step Word 2.

20-Bit Step Word

DB[22:3] determine the step word. Step word is a number of steps in the ramp.

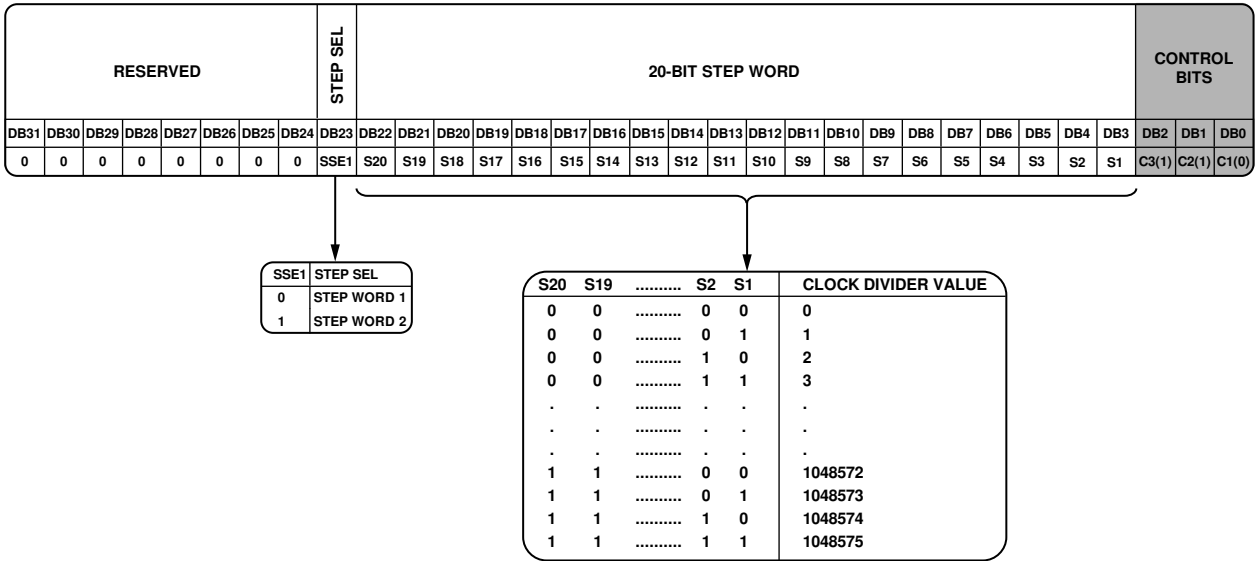

Figure 29. Step Register (R6) Map

08728-117

DELAY REGISTER (R7) MAP

With Register R7 DB[2:0] set to [1, 1, 1], the on-chip delay register is programmed as shown in Figure 30.

Reserved Bits

All reserved bits should be set to 0 for normal operation.

Ramp Delay Fast Lock

Setting DB18 to 1 enables the ramp delay fast-lock function. Setting DB18 to 0 disables this function.

Ramp Delay

Setting DB17 to 1 enables the ramp delay function. Setting DB17 to 0 disables this function.

Delay Clock Select

Setting DB16 to 0 selects the PFD clock as the delay clock. Setting DB16 to 1 selects PFD × CLK₁ (CLK₁ set by DB[14:3] in Register R2) as delay clock.

Delayed Start Enable

Setting DB15 to 1 enables delayed start. Setting DB15 to 0 disables delayed start.

12-Bit Delayed Start Word

DB[14:3] determine the delay start word. The delay start word affects the duration of the ramp start delay.

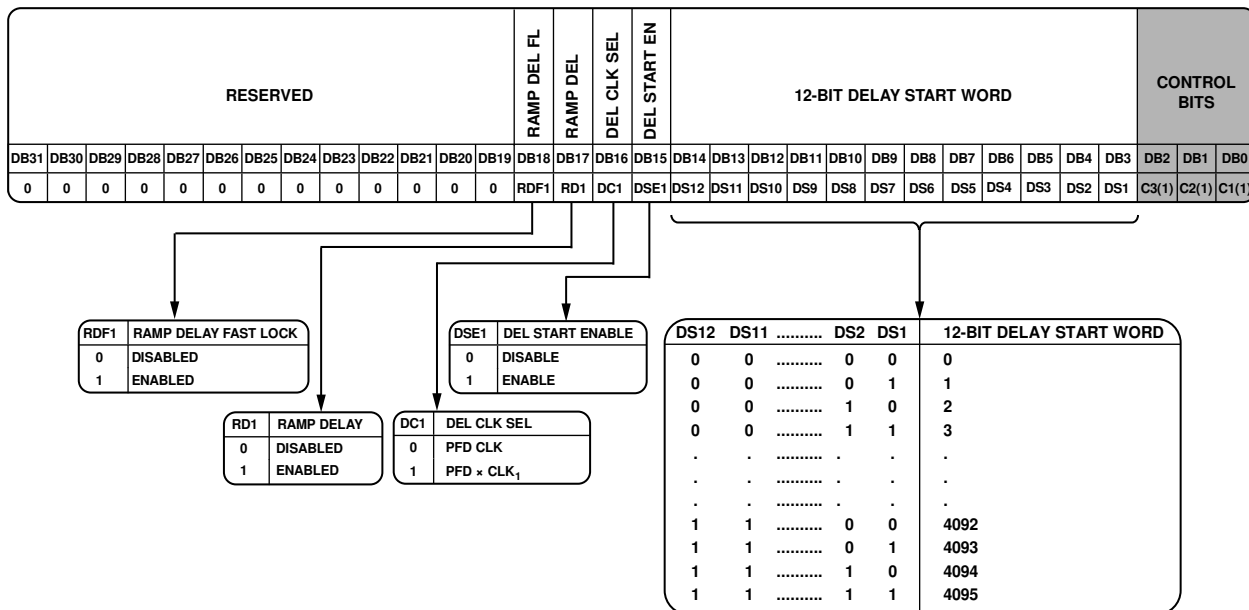

Figure 30. Delay Register (R7) Map

08728-118

APPLICATIONS INFORMATION

INITIALIZATION SEQUENCE

After powering up the part, administer the following programming sequence:

1. Delay register (R7)
2. Step register (R6)—load the step register (R6) twice, first with STEP SEL = 0 and then with STEP SEL = 1
3. Deviation register (R5)—load the deviation register (R5) twice, first with DEV SEL = 0 and then with DEV SEL = 1
4. Test register (R4)
5. Function register (R3)
6. R-divider register (R2)
7. LSB FRAC register (R1)
8. FRAC/INT register (R0)

RF SYNTHESIZER: A WORKED EXAMPLE

The following equation governs how the synthesizer should be programmed:

$$RF_{OUT} = [N + (FRAC/2^{25})] \times [f_{PFD}] \quad (4)$$

where:

RF_{OUT} is the RF frequency output.

N is the integer division factor.

$FRAC$ is the fractionality.

$$f_{PFD} = REF_{IN} \times [(1 + D)/(R \times (1 + T))] \quad (5)$$

where:

REF_{IN} is the reference frequency input.

D is the RF REF_{IN} doubler bit.

R is the RF reference division factor.

T is the reference divide-by-2 bit (0 or 1).

For example, in a system where a 5.8002 GHz RF frequency output (RF_{OUT}) is required and a 10 MHz reference frequency input (REF_{IN}) is available, the frequency resolution is

$$\begin{aligned} f_{RES} &= REF_{IN}/2^{25} \\ f_{RES} &= 10 \text{ MHz}/2^{25} \\ &= 0.298 \text{ Hz} \end{aligned} \quad (6)$$

From Equation 5,

$$\begin{aligned} f_{PFD} &= [10 \text{ MHz} \times (1 + 0)/1] = 10 \text{ MHz} \\ 5.8002 \text{ GHz} &= 10 \text{ MHz} \times (N + FRAC/2^{25}) \end{aligned}$$

Calculating N and $FRAC$ values,

$$\begin{aligned} N &= \text{int}(RF_{OUT}/f_{PFD}) = 580 \\ FRAC &= F_{MSB} \times 2^{13} + F_{LSB} \\ F_{MSB} &= \text{int}(((RF_{OUT}/f_{PFD}) - N) \times 2^{12}) = 81 \\ F_{LSB} &= \text{int}((((RF_{OUT}/f_{PFD}) - N) \times 2^{12}) - F_{MSB}) \times 2^{13} = 7537 \end{aligned}$$

where:

F_{MSB} is the 12-bit MSB FRAC value in Register R0.

F_{LSB} is the 13-bit LSB FRAC value in Register R1.

$\text{int}()$ makes an integer of the argument in parentheses.

REFERENCE DOUBLER AND REFERENCE DIVIDER

The reference doubler on chip allows the input reference signal to be doubled. This is useful for increasing the PFD comparison frequency. Making the PFD frequency higher improves the noise performance of the system. Doubling the PFD frequency usually improves noise performance by 3 dB.

It is important to note that the PFD cannot be operated above 32 MHz due to a limitation in the speed of the Σ - Δ circuit of the N-divider.

CYCLE SLIP REDUCTION FOR FASTER LOCK TIMES

In fast-locking applications, a wide loop filter bandwidth is required for fast frequency acquisition, resulting in increased integrated phase noise and reduced spur attenuation. Using cycle slip reduction, the loop bandwidth can be kept narrow to reduce integrated phase noise and attenuate spurs while still realizing fast lock times.

Cycle Slips

Cycle slips occur in integer-N/fractional-N synthesizers when the loop bandwidth is narrow compared with the PFD frequency. The phase error at the PFD inputs accumulates too fast for the PLL to correct, and the charge pump temporarily pumps in the wrong direction, slowing down the lock time dramatically. The ADF4158 contains a cycle slip reduction circuit to extend the linear range of the PFD, allowing faster lock times without loop filter changes.

When the ADF4158 detects that a cycle slip is about to occur, it turns on an extra charge pump current cell. This outputs a constant current to the loop filter or removes a constant current from the loop filter (depending on whether the VCO tuning voltage needs to increase or decrease to acquire the new frequency). The effect is that the linear range of the PFD is increased. Stability is maintained because the current is constant and is not a pulsed current.

If the phase error increases again to a point where another cycle slip is likely, the ADF4158 turns on another charge pump cell. This continues until the ADF4158 detects that the VCO frequency has gone past the desired frequency. It then begins to turn off the extra charge pump cells one by one until they are all turned off and the frequency is settled.

Up to seven extra charge pump cells can be turned on. In most applications, it is enough to eliminate cycle slips altogether, giving much faster lock times.

Setting Bit DB28 in the R-divider register (Register R2) to 1 enables cycle slip reduction. Note that a 45% to 55% duty cycle is needed on the signal at the PFD in order for CSR to operate correctly. The reference divide-by-2 flip-flop can help to provide a 50% duty cycle at the PFD. For example, if a 100 MHz reference frequency is available and the user wants to run the PFD at 10 MHz, setting the R-divide factor to 10 results in a 10 MHz PFD signal that is not 50% duty cycle. By setting the R-divide factor to 5 and enabling the reference divide-by-2 bit, a 50% duty cycle 10 MHz signal can be achieved.

Note that the cycle slip reduction feature can only be operated when the phase detector polarity setting is positive (DB6 in Register R3). It cannot be used if the phase detector polarity is negative.

MODULATION

The ADF4158 can operate in frequency shift keying (FSK) or phase shift keying (PSK) mode.

Frequency Shift Keying (FSK)

FSK is implemented by setting the ADF4158 N-divider up for the center frequency and then toggling the TX_{DATA} pin. The deviation from the center frequency is set by

$$f_{DEV} = (f_{PFD}/2^{25}) \times (DEV \times 2^{DEV_OFFSET}) \tag{7}$$

where:

f_{PFD} is the PFD frequency.

DEV is a 16-bit word.

DEV_OFFSET is a 4-bit word.

The ADF4158 implements this by incrementing or decrementing the set N-divide value by $DEV \times 2^{DEV_OFFSET}$.

Phase Shift Keying (PSK)

When the ADF4158 is set up in PSK mode, it is possible to toggle the output phase of the ADF4158 between 0° and 180°. The TX_{DATA} pin controls the phase.

FSK Settings Worked Example

For example, take an FSK system operating at 5.8 GHz, with a 25 MHz PFD, 250 kHz deviation and $DEV_OFFSET = 4$. Rearrange Equation 4 as follows

$$DEV = \frac{f_{DEV}}{\frac{f_{PFD}}{2^{25}} \times 2^{DEV_OFFSET}} \tag{8}$$

$$DEV = \frac{250 \text{ kHz}}{\frac{25 \text{ MHz}}{2^{25}} \times 2^4} = 20,971.52$$

The DEV value is rounded to 20,972. Toggling the TX_{DATA} pin causes the frequency to hop between ±250 kHz frequencies from the programmed center frequency.

WAVEFORM GENERATION

The ADF4158 is capable of generating four types of waveforms in the frequency domain: single ramp burst, single sawtooth burst, sawtooth ramp, and triangular ramp. Figure 31 through Figure 34 show the types of waveforms available.

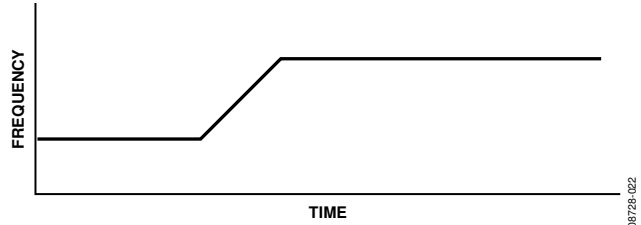

Figure 31. Single Ramp Burst

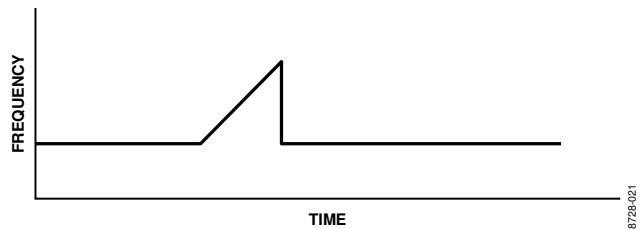

Figure 32. Single Sawtooth Burst

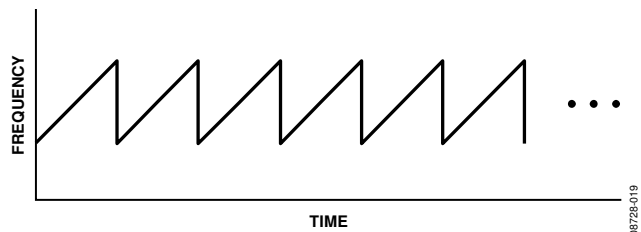

Figure 33. Sawtooth Ramp

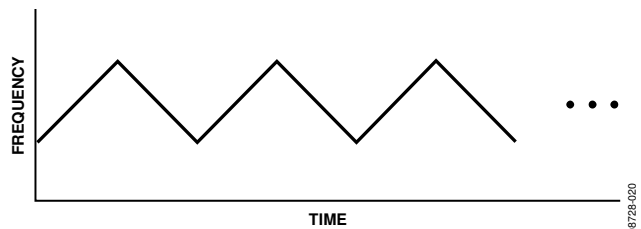

Figure 34. Triangular Ramp

Waveform Deviations and Timing

Figure 35 shows a version of a burst or ramp. The key parameters that define a burst or ramp are

- Frequency deviation
- Timeout interval
- Number of steps

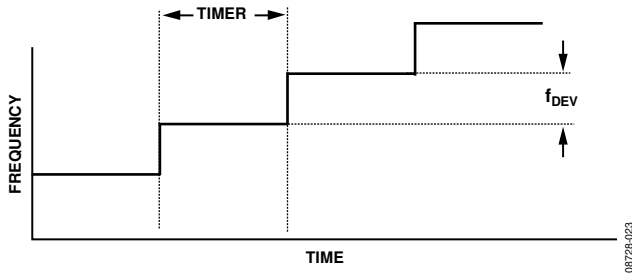

Figure 35. Waveform Timing

Frequency Deviation

The frequency deviation for each frequency hop is set by

$$f_{DEV} = (f_{PFD}/2^{25}) \times (DEV \times 2^{DEV_OFFSET}) \quad (9)$$

where:

f_{PFD} is the PFD frequency.

DEV is a 16-bit word.

DEV_OFFSET is a 4-bit word.

Timeout Interval

The time between each frequency hop is set by

$$Timer = CLK_1 \times CLK_2 \times (1/f_{PFD}) \quad (10)$$

where:

CLK_1 and CLK_2 are 12-bit clock values (12-bit CLK_1 divider in R2, 12-bit clock divider in R4—CLK DIV set as RAMP DIV).

f_{PFD} is the PFD frequency.

Number of Steps

A 20-bit step value defines the number of frequency hops that take place. The INT value cannot be incremented by more than $2^8 = 256$ from its starting value.

Single Ramp Burst

The most basic waveform is the single ramp burst. All other waveforms are slight variations on this.

In the single ramp burst, the ADF4158 is locked to the frequency defined in the FRAC/INT register. When the ramp mode is enabled, the ADF4158 increments the N-divide value by $DEV \times 2^{DEV_OFFSET}$, causing a frequency shift, f_{DEV} , on each timer interval. This happens until the set number of steps has taken place. The ADF4158 then retains the final N-divide value.

Single Sawtooth Burst

In the single sawtooth burst, the N-divide value is reset to its initial value on the next timeout interval after the number of steps has taken place. The ADF4158 retains this N-divide value.

Sawtooth Ramp

The sawtooth ramp is a repeated version of the single sawtooth burst. The waveform repeats until the ramp is disabled.

Triangular Ramp

The triangular ramp is similar to the single ramp burst. However, when the steps have been completed, the ADF4158 begins to decrement the N-divide value by $DEV \times 2^{DEV_OFFSET}$ on each timeout interval. When the number of steps has again been completed, it reverts to incrementing the N-divide value. Repeating this creates a triangular waveform. The waveform repeats until the ramp is disabled.

FMCW Radar Ramp Settings Worked Example

Take as an example, an FMCW radar system requiring the RF LO to sawtooth ramp over a 50 MHz range every 2 ms. The PFD frequency is 25 MHz, and the RF output range is 5800 MHz to 5850 MHz.

The frequency deviation for each hop in the ramp is set to ~250 kHz.

The frequency resolution of ADF4158 is calculated as follows:

$$f_{RES} = f_{PFD}/2^{25} \quad (11)$$

Numerically:

$$f_{RES} = 25 \text{ MHz}/2^{25} = 0.745 \text{ Hz}$$

The DEV_OFFSET is calculated after rearranging Equation 9:

$$DEV_OFFSET = \log_2(f_{DEV}/(f_{RES} \times DEV_{MAX})) \quad (12)$$

Expressed in $\log_{10}(x)$, Equation 10 can be transformed into the following equation:

$$DEV_OFFSET = \log_{10}(f_{DEV}/(f_{RES} \times DEV_{MAX}))/\log_{10}(2) \quad (13)$$

where:

DEV_OFFSET = a 4-bit word.

f_{DEV} = frequency deviation.

DEV_{MAX} (Maximum of the Deviation Word) = 2^{15}

Using Equation 13, DEV_OFFSET is calculated as follows

$$DEV_OFFSET = \log_{10}(250 \text{ kHz}/(0.745 \text{ Hz} \times 2^{15}))/\log_{10}(2) = 3.356$$

After rounding, $DEV_OFFSET = 4$.

From DEV_OFFSET , the resolution of frequency deviation can be calculated as follows

$$f_{DEV_RES} = f_{RES} \times 2^{DEV_OFFSET} \quad (14)$$

$$f_{DEV_RES} = 0.745 \text{ Hz} \times 2^4 = 11.92 \text{ Hz}$$

To calculate the DEV word, use Equation 15.

$$DEV = f_{DEV} / (f_{RES} \times 2^{DEV_OFFSET}) \quad (15)$$

$$DEV = \frac{250 \text{ kHz}}{\frac{25 \text{ MHz}}{2^{25}} \times 2^4} = 20,971.52$$

Rounding this to 20,972 and recalculating using Equation 9 to get the actual deviation frequency, f_{DEV} , thus produces the following:

$$f_{DEV} = (25 \text{ MHz} / 2^{25}) \times (20,972 \times 2^4) = 250.006 \text{ kHz}$$

The number of f_{DEV} steps required to cover the 50 MHz range is $50 \text{ MHz} / 250.006 \text{ kHz} = 200$. To cover the 50 MHz range in 2 ms, the ADF4158 must hop every $2 \text{ ms} / 200 = 10 \mu\text{s}$.

Rearrange Equation 10 to set the timer value (and fix CLK_2 to 1):

$$CLK_1 = \text{Timer} \times f_{PFD} / CLK_2 = 10 \mu\text{s} \times 25 \text{ MHz} / 1 = 250$$

To summarize the settings: $DEV = 20,972$, number of steps = 200, $CLK_1 = 250$ (12-bit CLK_1 divider in R2), $CLK_2 = 1$ (R4— $CLK \text{ DIV}$ set as RAMP DIV). Using these settings, program the ADF4158 to a center frequency of 5800 MHz, and enable the sawtooth ramp to produce the required waveform. If a triangular ramp was used with the same settings, the ADF4158 would sweep from 5800 MHz to 5850 MHz and back down again. The entire sweep would take 4 ms.

Activating the Ramp

After setting all of the previous parameters, the ramp must be activated. It is achieved by choosing the desired type of ramp (DB[11:10] in Register R3) and starting the ramp (DB31 = 1 in Register R0).

Ramp Programming Sequence

Set parameters as described in the FMCW Radar Ramp Settings Worked Example section and activate the ramp as described in the Activating the Ramp section in the following register write order.

1. Delay register (R7)
2. Step register (R6)
3. Deviation register (R5)
4. Test register (R4)
5. Function register (R3)
6. R-divider register (R2)
7. LSB FRAC register (R1)
8. FRAC/INT register (R0)

OTHER WAVEFORMS

Two Ramp Rates

This feature allows for two ramps with different step and deviation settings. It also allows the ramp rate to be reprogrammed while another ramp is running.

Example

If, for example

- PLL is locked to 5790 MHz and $f_{PFD} = 25\text{MHz}$.
- Ramp 1 jumps 100 steps, each of which lasts $10 \mu\text{s}$ and has a frequency deviation of 100 kHz.
- Ramp 2 jumps 80 steps, each of which lasts $10 \mu\text{s}$ and has a frequency deviation of 125 kHz.

Then,

1. DB24 in Register R5 should be set to 1, which activates Ramp 2 rates mode.
2. Program Ramp 1 and Ramp 2 as follows to get two ramp rates:
Ramp 1: Register R5 DB[18:3] = 16,777, DB[22:19] = 3 with DB23 = 0; Register R6 DB[22:3] = 100, DB23 = 0.
Ramp 2: Register R5 DB[18:3] = 20,972, DB[22:19] = 3 with DB23 = 1; Register R6 DB[22:3] = 80, DB23 = 1.

The resulting ramp with two various rates is shown in Figure 36. Eventually, the ramp must be activated as described in the Activating the Ramp section.

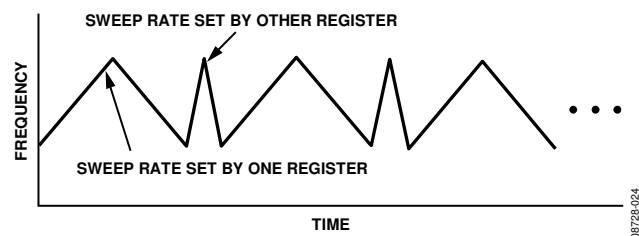

Figure 36. Dual Sweep Rate

Ramp Mode with FSK Signal on Ramp

In traditional approaches a FMCW radars used either linear frequency modulation (LFM) or FSK modulation. These modulations used separately introduce ambiguity between measured distance and velocity, especially in multitarget situations. To overcome this issue and enable unambiguous (range – velocity) multitarget detection, use a ramp with FSK on it.

Example

If, for example

- PLL is locked to 5790 MHz. $f_{PFD} = 25\text{MHz}$
- There are 100 steps each of which lasts $10 \mu\text{s}$ and has a deviation of 100 kHz.
- The FSK signal is 25 kHz.

Then,

1. Program the ramp as described in the FMCW Radar Ramp Settings Worked Example section. While doing that DB23 in Register R5 and DB23 in Register R6 should be set to 0.
2. Set the bits in Register R5 as follows to program FSK on ramp to 25 kHz: DB[18:3] = 4194 (deviation word), DB[22:19] = 3 (deviation offset), DB23 = 1 (deviation select for FSK on ramp), and DB25 = 1 (ramp with FSK enabled).

An example of ramp with FSK on the top of it is shown in Figure 37. Eventually, the ramp must be activated as described in the Activating the Ramp section.

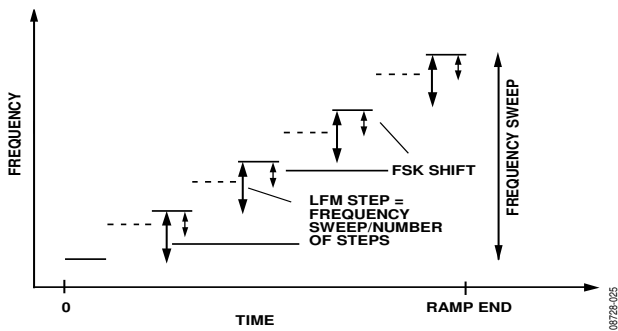

Figure 37. Combined FSK and LFM Waveform (N Corresponds to the Number of LFM Steps)

Delayed Start

A delayed start can be used with two different parts to control the start time. The idea of delayed start is shown in Figure 38.

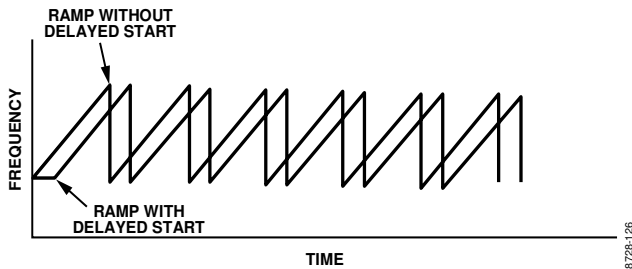

Figure 38. Delayed Start of Sawtooth Ramp

Example

For example, to program a delayed start with two different parts to control the start time,

1. Set DB15 in Register R7 to 1 to enable the delayed start of ramp option.
2. Set Bit DB16 in Register R7 to 0 and the 12-bit delay start word (DB[14:3] in Register R7) to 125 to delay the ramp on the first part is delayed by 5 μs, $f_{\text{PFD}} = 25 \text{ MHz}$. The delay is calculated as follows:

$$\begin{aligned} \text{Delay} &= t_{\text{PFD}} \times \text{Delay Start Word} \\ &= 40 \text{ ns} \times 125 = 5 \mu\text{s} \end{aligned}$$

3. Set Bit DB16 in Register R7 to 1 and the 12-bit delay start word (DB[14:3] in Register R7) to 125 to delay the ramp on the second part is delayed by 125 μs. Use the following formula for calculating the delay:

$$\begin{aligned} \text{Delay} &= t_{\text{PFD}} \times \text{CLK}_1 \times \text{Delay Start Word} \\ &= 40 \text{ ns} \times 25 \times 125 = 125 \mu\text{s} \end{aligned}$$

Eventually, the ramp must be activated as described in the Activating the Ramp section.

Delay Between Ramps

This feature adds a delay between bursts in ramp. Figure 39 shows a delay between ramps in sawtooth mode.

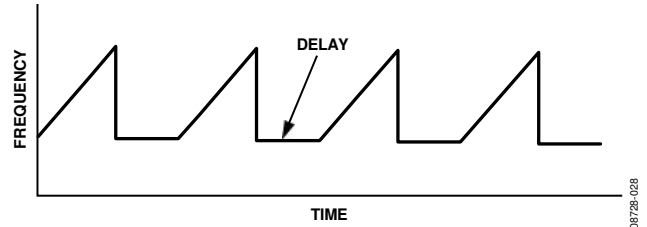

Figure 39. Delay Between Ramps for Sawtooth Mode

Example

For example, to add a delay between bursts in a ramp,

1. Set DB17 in Register R7 to 1 to enable delay between ramps option.
2. Set Bit DB16 in Register R7 to 0 and the 12-bit delay start word (DB[14:3] in Register R7) to 125 to delay the ramp by 5 μs, $f_{\text{PFD}} = 25 \text{ MHz}$. The delay is calculated as follows:

$$\begin{aligned} \text{Delay} &= t_{\text{PFD}} \times \text{Delay Start Word} \\ &= 40 \text{ ns} \times 125 = 5 \mu\text{s} \end{aligned}$$

If a longer delay is needed, for example, 125 μs, Bit DB16 in Register R7 should be set to 1 and the 12-bit delay start word (DB[14:3] in Register R7) should be set to 125. The delay is calculated as follows

$$\begin{aligned} \text{Delay} &= t_{\text{PFD}} \times \text{CLK}_1 \times \text{Delay Start Word} \\ &= 40 \text{ ns} \times 25 \times 125 = 125 \mu\text{s} \end{aligned}$$

There is also a possibility to activate fast-lock operation for the first period of delay. This is done by setting Bit DB18 in Register R7 to 1. This feature is useful for sawtooth ramps to mitigate the frequency overshoot on the transition from one sawtooth to the next. Eventually, the ramp must be activated as described in the Activating the Ramp section.

Nonlinear Ramp Mode

The ADF4158 is capable of generating a parabolic ramp. The output frequency is generated according to the following equation:

$$f_{\text{OUT}}(n + 1) = f_{\text{OUT}}(n) + n \times f_{\text{DEV}} \tag{16}$$

where:

f_{OUT} is output frequency.

n is step number.

f_{DEV} is frequency deviation.

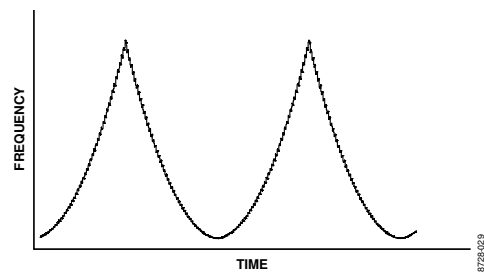

Figure 40. Parabolic Ramp

The following example explains how to set up and use this function.

Example

$$f_{OUT} = 5790 \text{ MHz}$$

$$f_{DEV} = 100 \text{ kHz}$$

Number of steps = 50

Duration of a single step = 10 μ s

Ramp mode must be either triangular (Register R3, DB[11:10] = 01) or single ramp burst (Register R3, DB[11:10] = 11).

In the first case, the generated frequency range is calculated as follows:

$$\Delta f = f_{DEV} \times (\text{Number of Steps} + 2) \times (\text{Number of Steps} + 1) / 2$$

$$= 132.6 \text{ MHz}$$

In the second case, the generated frequency range is calculated as follows:

$$\Delta f = f_{DEV} \times (\text{Number of Steps} + 1) \times \text{Number of Steps} / 2$$

$$= 127.5 \text{ MHz}$$

The timer is set in the same way as for its linear ramps described in the Waveform Generation section.

Activation of the parabolic ramp is achieved by setting Bit DB28 in Register R5 to 1.

Next the counter reset (DB3 in Register R3) should be set first to 1 and then to 0.

Eventually, the ramp must be activated as described in the Activating the Ramp section.

Ramp Complete Signal to MUXOUT

Ramp complete signal on MUXOUT is shown in Figure 41.

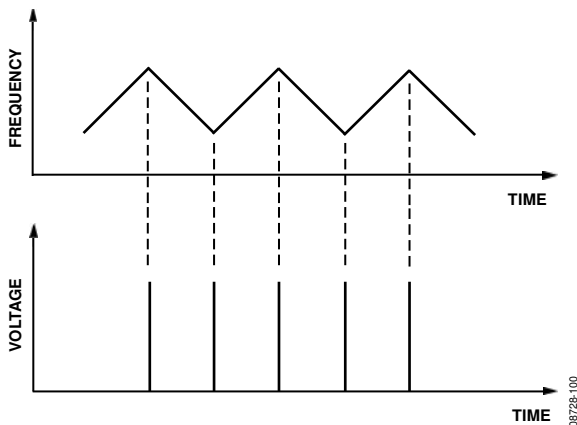

Figure 41. Ramp Complete Signal on MUXOUT

To activate this function DB[30:27] = 1111 in Register 0 and DB[25:21] = 00011 in Register 4.

EXTERNAL CONTROL OF RAMP STEPS

The internal ramp clock can be bypassed and each step can be triggered by a pulse on the TX_{DATA} pin. This allows for more transparent control of each step. Enable this feature by setting Bit DB29 in Register R5 to 1.

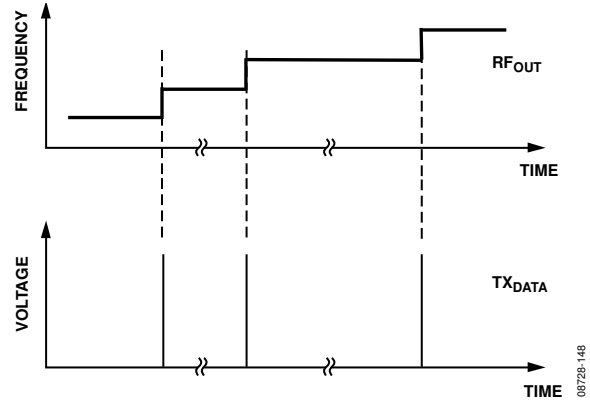

Figure 42. External Control of Ramp Steps

Interrupt Modes and Frequency Readback

Interrupt modes are triggered from the rising edge of TX_{DATA}. Depending on the settings of DB[27:26] in Register R5, the modes in Table 7 are activated.

Table 7. Interrupt Modes

| Mode | Action |
|----------------|---|
| DB[27:26] = 00 | Interrupt is off |
| DB[27:26] = 01 | Interrupt on TX _{DATA} , sweep continues |
| DB[27:26] = 11 | Interrupt on TX _{DATA} , sweep stops |

When an interrupt takes place, the data consisting of the INT and FRAC values can be read back via MUXOUT. The data is made up of 37 bits, 12 of which represent the INT value and 25 the FRAC value.

The idea of frequency readback is shown in Figure 43.

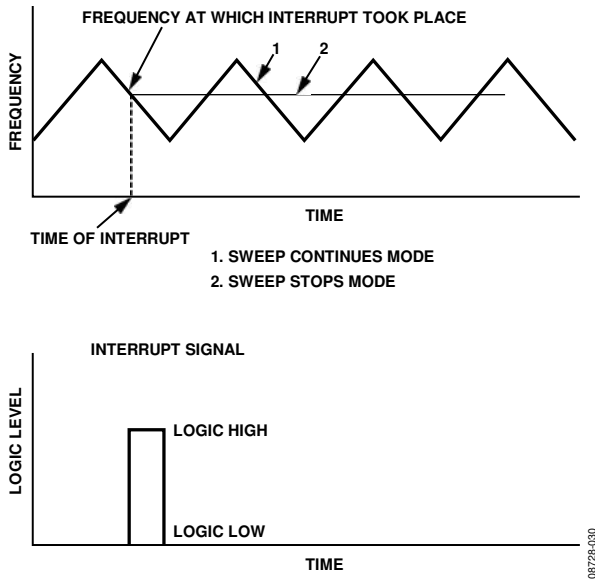

Figure 43. Interrupt and Frequency Readback

Note that DB[22:21] in Register R4 should be set to 0b10 and DB[30:27] in Register R0 (MUXOUT control) should be set to 15 (1111).

The mechanism of how single bits are read back is shown in Figure 44.

For continuous frequency readback the following sequence should be used:

- Register 0 write
- LE high
- Pulse on TX_{DATA}
- Frequency readback (as described at the beginning of the Interrupt Modes and Frequency Readback section and Figure 44)
- Pulse on TX_{DATA}
- Register R4 write
- Frequency readback (as described at the beginning of the Interrupt Modes and Frequency Readback section and Figure 44)
- Pulse on TX_{DATA}
- ...

The sequence is also shown in Figure 45.

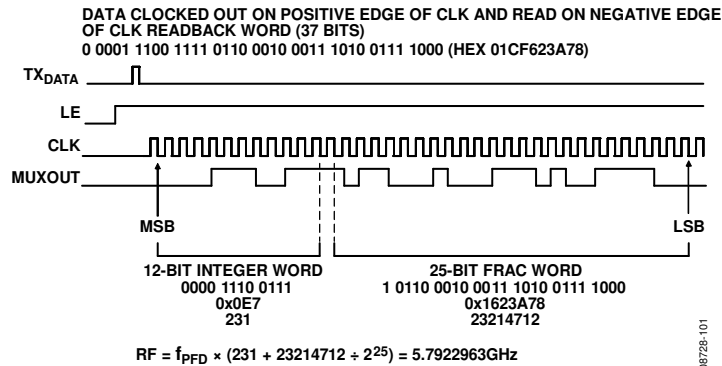

Figure 44. Reading Back Single Bits to Determine the Output Frequency at the Moment of Interrupt

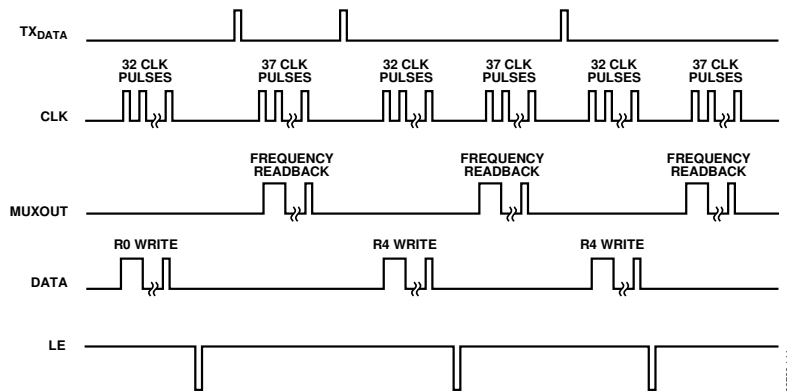

Figure 45. Continuous Frequency Readback

FAST LOCK MODE

The ADF4158 can operate in fast lock mode. In this mode, the charge pump current is boosted and additional resistors are connected to maintain the stability of the loop.

Fast Lock Timer and Register Sequences

When fast lock mode is enabled (Register R4, DB[20:19]), after a write to Register R0, the PLL operates in a wide bandwidth mode for a selected amount of time. Before fast lock is enabled, the initialization sequence must be performed after the part is first powered up (see the Initialization Sequence section). The time in bandwidth mode is set by:

$$CLK_1 \times CLK_2 / f_{PFD} = \text{Time in Wide Bandwidth}$$

where:

CLK₁ = Register R2, DB[14:3].

CLK₂ = Register R4, DB[18:7].

f_{PFD} = the PFD frequency.

Note that the fast lock feature does not work in ramp mode.

Fast Lock Example

In this example, the PLL has f_{PFD} of 100 MHz and requires being in wide bandwidth mode for 12 μs.

$$CLK_1 \times CLK_2 / f_{PFD} = 12 \mu s$$

$$CLK_1 \times CLK_2 = (12 \times 10^{-6})(100 \times 10^6) = 1200$$

Therefore, CLK₁ = 12 and CLK₂ = 100, which results in 12 μs.

Fast Lock Loop Filter Topology

To use fast lock mode, an extra connection from the PLL to the loop filter is needed. The damping resistor in the loop filter must be reduced to ¼ of its value in wide bandwidth mode. This reduction is required because the charge pump current is increased by 16 in wide bandwidth mode, and stability must be ensured.

To further enhance stability and mitigate frequency overshoot during a frequency change in wide bandwidth mode, Resistor R3 is connected (see Figure 46). During fast lock, the SW1 pin is shorted to ground, and the SW2 pin is connected to CP (set Bits DB[20:19] in Register R4 to 01 for fast lock divider).

The following two topologies can be used:

- Divide the damping resistor (R1) into two values (R1 and R1A) that have a ratio of 1:3 (see Figure 46).
- Connect an extra resistor (R1A) directly from SW1 (see Figure 47). The extra resistor must be selected such that the parallel combination of an extra resistor and the damping resistor (R1) is reduced to ¼ of the original value of R1.

For both topologies, the ratio R3:R2 must equal 1:4.

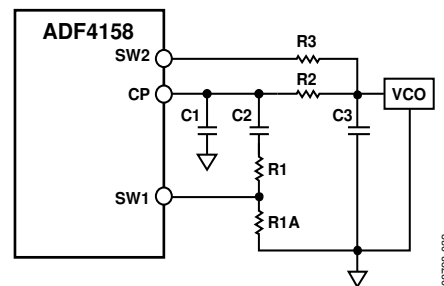

Figure 46. Fast-Lock Loop Filter Topology—Topology 1

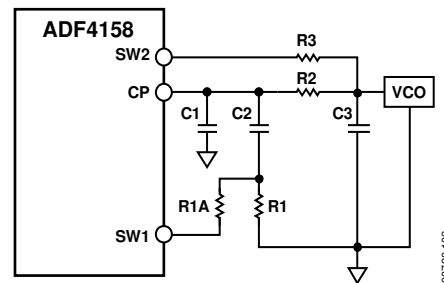

Figure 47. Fast-Lock Loop Filter Topology—Topology 2

For more fast lock topologies, see [ADIsimPLL](#).

SPUR MECHANISMS

The fractional interpolator in the ADF4158 is a third-order Σ - Δ modulator (SDM) with a 25-bit fixed modulus (MOD). The SDM is clocked at the PFD reference rate (f_{PFD}) that allows PLL output frequencies to be synthesized at a channel step resolution of $f_{\text{PFD}}/\text{MOD}$. The various spur mechanisms possible with fractional-N synthesizers and how they affect the ADF4158 are discussed in this section.

Fractional Spurs

In most fractional synthesizers, fractional spurs can appear at the set channel spacing of the synthesizer. In the ADF4158, these spurs do not appear. The high value of the fixed modulus in the ADF4158 makes the SDM quantization error spectrum look like broadband noise, effectively spreading the fractional spurs into noise.

Integer Boundary Spurs

Interactions between the RF VCO frequency and the PFD frequency can lead to spurs known as integer boundary spurs. When these frequencies are not integer related (which is the purpose of the fractional-N synthesizer), spur sidebands appear on the VCO output spectrum at an offset frequency that corresponds to the beat note or difference frequency between an integer multiple of the PFD and the VCO frequency.

These spurs are named integer boundary spurs because they are more noticeable on channels close to integer multiples of the PFD where the difference frequency can be inside the loop bandwidth. These spurs are attenuated by the loop filter on channels far from integer multiples of the PFD.

Reference Spurs

Reference spurs are generally not a problem in fractional-N synthesizers because the reference offset is far outside the loop bandwidth. However, any reference feedthrough mechanism that bypasses the loop can cause a problem. One such mechanism is the feedthrough of low levels of on-chip reference switching noise out through the RF_{IN} pins back to the VCO, resulting in reference spur levels as high as -90 dBc. Take care in the printed circuit board (PCB) layout to ensure that the VCO is well separated from the input reference to avoid a possible feedthrough path on the board.

LOW FREQUENCY APPLICATIONS

The specification on the RF input is 0.5 GHz minimum; however, RF frequencies lower than this can be used if the minimum slew rate specification of 400 V/ μ s is met. An appropriate LVDS driver can be used to square up the RF signal before it is fed back to the ADF4158 RF input. The FIN1001 from Fairchild Semiconductor is one such LVDS driver.

FILTER DESIGN—ADIsimPLL

A filter design and analysis program is available to help the user implement PLL design. Visit <http://www.analog.com/pll> for a free download of the ADIsimPLL software. This software designs, simulates, and analyzes the entire PLL frequency domain and time domain response. Various passive and active filter architectures are allowed.

PCB DESIGN GUIDELINES FOR THE CHIP SCALE PACKAGE

The lands on the chip scale package (CP-24) are rectangular. The PCB pad for these should be 0.1 mm longer than the package land length and 0.05 mm wider than the package land width. Center the land on the pad. This ensures that the solder joint size is maximized.

The bottom of the chip scale package has a central thermal pad. The thermal pad on the PCB should be at least as large as this exposed pad. On the PCB, there should be a clearance of at least 0.25 mm between the thermal pad and the inner edges of the pad pattern. This ensures that shorting is avoided.

Thermal vias can be used on the PCB thermal pad to improve the thermal performance of the package. If vias are used, they should be incorporated into the thermal pad at 1.2 mm pitch grid. The via diameter should be between 0.3 mm and 0.33 mm, and the via barrel should be plated with 1 ounce of copper to plug the via. Connect the PCB thermal pad to AGND.

APPLICATION OF ADF4158 IN FMCW RADAR

The ADF4158 in FMCW radar is used for generating ramps (sawtooth or triangle) that are necessary for this type of radar to operate. Traditionally, the PLL was driven directly by a direct digital synthesizer (DDS) to generate the required type of waveform.

Due to the implemented waveform generating mechanism on the ADF4158, a DDS is no longer needed, which reduces cost. In addition, the PLL solution has advantages over another method

(the DAC driving the VCO directly) for generating FMCW ramps, which suffered from VCO tuning characteristics nonlinearities requiring compensation. The PLL method gives highly linear ramps without the need for calibration.

The application of ADF4158 in FMCW radar is shown in Figure 48.

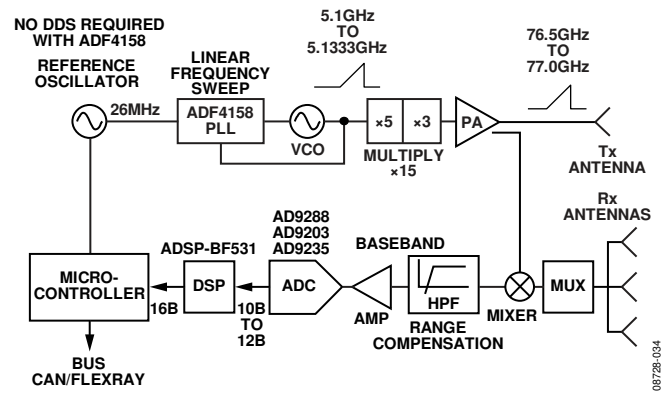
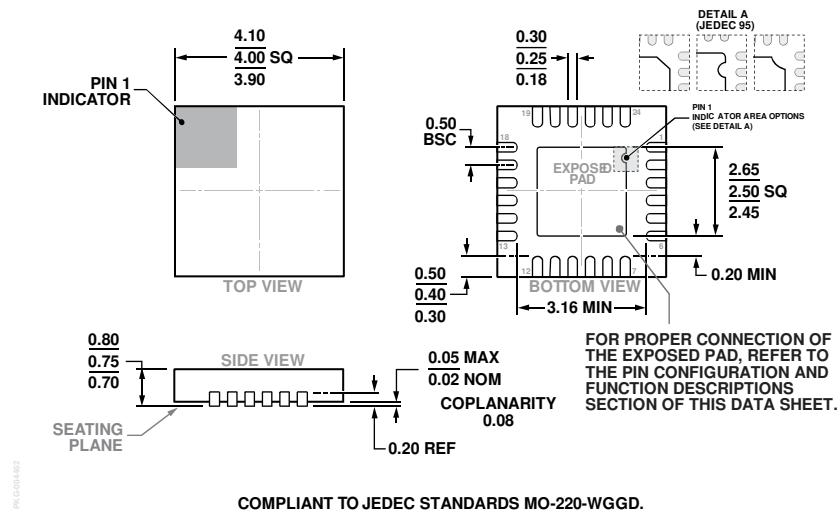

Figure 48. FMCW Radar with ADF4158

OUTLINE DIMENSIONS



COMPLIANT TO JEDEC STANDARDS MO-220-WGGD.
 Figure 49. 24-Lead Lead Frame Chip Scale Package [LFCSP]
 4 mm × 4 mm Body and 0.75 mm Package Height
 (CP-24-7)
 Dimensions shown in millimeters

ORDERING GUIDE

| Model ^{1,2} | Temperature Range | Package Description | Package Option |
|----------------------|-------------------|---|----------------|
| ADF4158CCPZ | -40°C to +125°C | 24-Lead Lead Frame Chip Scale Package [LFCSP] | CP-24-7 |
| ADF4158CCPZ-RL7 | -40°C to +125°C | 24-Lead Lead Frame Chip Scale Package [LFCSP] | CP-24-7 |
| ADF4158WCCPZ | -40°C to +125°C | 24-Lead Lead Frame Chip Scale Package [LFCSP] | CP-24-7 |
| ADF4158WCCPZ-RL7 | -40°C to +125°C | 24-Lead Lead Frame Chip Scale Package [LFCSP] | CP-24-7 |
| EVAL-ADF4158EB1Z | | Evaluation Board | |

¹ Z = RoHS Compliant Part.
² W = Qualified for Automotive Applications.

AUTOMOTIVE PRODUCTS

The [ADF4158W](#) models are available with controlled manufacturing to support the quality and reliability requirements of automotive applications. Note that these automotive models may have specifications that differ from the commercial models; therefore, designers should review the Specifications section of this data sheet carefully. Only the automotive grade products shown are available for use in automotive applications. Contact your local Analog Devices account representative for specific product ordering information and to obtain the specific Automotive Reliability reports for these models.

¹²C refers to a communications protocol originally developed by Philips Semiconductors (now NXP Semiconductors).