



Precision LOGARITHMIC AND LOG RATIO AMPLIFIER

FEATURES

- EASY-TO-USE COMPLETE CORE FUNCTION
- HIGH ACCURACY: 0.01% FSO Over 5 Decades
- WIDE INPUT DYNAMIC RANGE:
7.5 Decades, 100pA to 3.5mA
- LOW QUIESCENT CURRENT: 1mA
- WIDE SUPPLY RANGE: $\pm 4.5V$ to $\pm 18V$

APPLICATIONS

- LOG, LOG RATIO COMPUTATION:
Communication, Analytical, Medical, Industrial,
Test, General Instrumentation
- PHOTODIODE SIGNAL COMPRESSION AMP
- ANALOG SIGNAL COMPRESSION IN FRONT
OF ANALOG-TO-DIGITAL(A/D) CONVERTER

DESCRIPTION

The LOG104 is a versatile integrated circuit that computes the logarithm or log ratio of an input current relative to a reference current.

The LOG104 is tested over a wide dynamic range of input signals. In log ratio applications, a signal current can come from a photodiode, and a reference current from a resistor in series with a precision external reference.

The output signal at V_{OUT} is trimmed to 0.5V per decade of input current, allowing seven decades of input current, dynamic range.

Low DC offset voltage and temperature drift allow accurate measurement of low-level signals over a wide environmental temperature range. The LOG104 is specified over the temperature range $-5^{\circ}C$ to $+75^{\circ}C$, with operation over $-40^{\circ}C$ to $+85^{\circ}C$.

Note: Protected under US Patent #6,667,650; other patents pending.

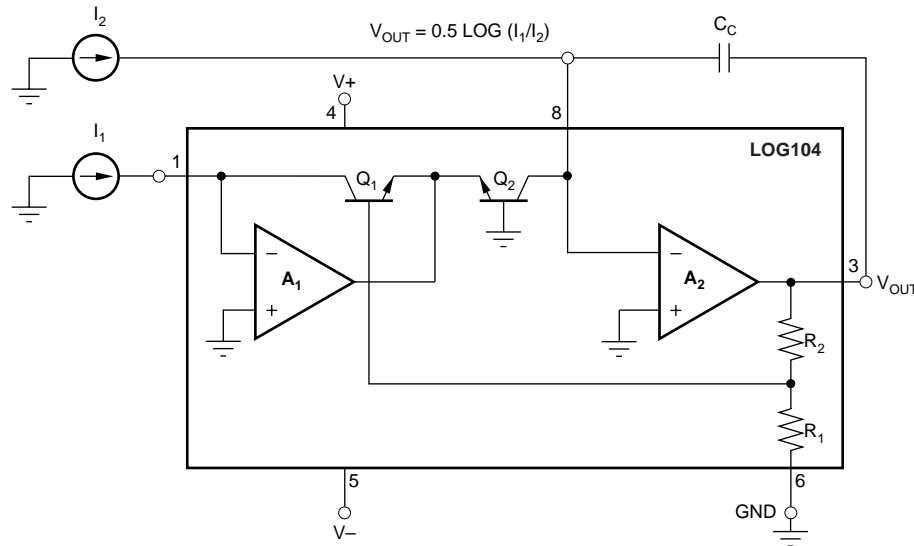

Please be aware that an important notice concerning availability, standard warranty, and use in critical applications of Texas Instruments semiconductor products and disclaimers thereto appears at the end of this data sheet.

All trademarks are the property of their respective owners.

PRODUCTION DATA information is current as of publication date. Products conform to specifications per the terms of Texas Instruments standard warranty. Production processing does not necessarily include testing of all parameters.



Copyright © 2002-2005, Texas Instruments Incorporated

ABSOLUTE MAXIMUM RATINGS⁽¹⁾

Supply Voltage, V+ to V-	36V
Input Voltage	V- (-0.5) to V+ (+0.5V)
Input Current	±10mA
Output Short-Circuit ⁽²⁾	Continuous
Operating Temperature	-40°C to +85°C
Storage Temperature	-55°C to +125°C
Junction Temperature	+150°C
Lead Temperature (soldering, 10s)	+300°C

NOTES: (1) Stresses above these ratings may cause permanent damage. Exposure to absolute maximum conditions for extended periods may degrade device reliability. (2) Short-circuit to ground.



ELECTROSTATIC DISCHARGE SENSITIVITY

This integrated circuit can be damaged by ESD. Texas Instruments recommends that all integrated circuits be handled with appropriate precautions. Failure to observe proper handling and installation procedures can cause damage.

ESD damage can range from subtle performance degradation to complete device failure. Precision integrated circuits may be more susceptible to damage because very small parametric changes could cause the device not to meet its published specifications.

PIN DESCRIPTION

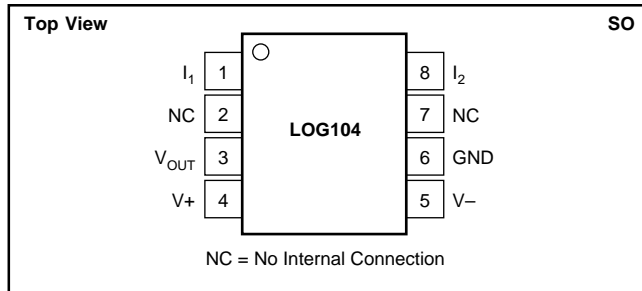

PACKAGE/ORDERING INFORMATION⁽¹⁾

PRODUCT	PACKAGE-LEAD	PACKAGE DESIGNATOR	PACKAGE MARKING
LOG104AID	SO-8	D	LOG104

NOTES: (1) For the most current package and ordering information, see the Package Option Addendum at the end of this document, or see the TI website at www.ti.com.

ELECTRICAL CHARACTERISTICS

Boldface limits apply over the specified temperature range, $T_A = -5^\circ\text{C}$ to $+75^\circ\text{C}$.

At $T_A = +25^\circ\text{C}$, $V_S = \pm 5\text{V}$, $R_{OUT} = 10\text{k}\Omega$, unless otherwise noted.

PARAMETER	CONDITION	LOG104AID			UNITS
		MIN	TYP	MAX	
CORE LOG FUNCTION I_{IN}/V_{OUT} Equation					V
LOG CONFORMITY ERROR⁽¹⁾ Initial	1nA to 100 μ A (5 decades)		0.01	0.2	%
	100pA to 3.5mA (7.5 decades)		0.06		%
over Temperature	1nA to 100 μ A (5 decades)		0.0001		%/°C
	100pA to 3.5mA (7.5 decades) ⁽²⁾		0.0005		%/°C
GAIN⁽³⁾ Initial Value	1nA to 100 μ A		0.5		V/decade
Gain Error	1nA to 100 μ A		0.15	±1	%
vs Temperature	T_{MIN} to T_{MAX}		0.003	0.01	%/°C
INPUT, A1 and A2 Offset Voltage			±0.3	±1.5	mV
vs Temperature	T_{MIN} to T_{MAX}		±2		$\mu\text{V}/^\circ\text{C}$
vs Power Supply (PSRR)	$V_S = \pm 4.5\text{V}$ to $\pm 18\text{V}$		5	50	$\mu\text{V}/\text{V}$
Input Bias Current			±5		pA
vs Temperature	T_{MIN} to T_{MAX}		Doubles Every 10°C		
Voltage Noise	$f = 10\text{Hz}$ to 10kHz		3		μVrms
	$f = 1\text{kHz}$		30		$\text{nV}/\sqrt{\text{Hz}}$
Current Noise	$f = 1\text{kHz}$		4		$\text{fA}/\sqrt{\text{Hz}}$
Common-Mode Voltage Range (Positive)		(V+) - 2	(V+) - 1.5		V
(Negative)		(V-) + 2	(V-) + 1.2		V
Common-Mode Rejection Ratio (CMRR)			105		dB
OUTPUT, A2 (V_{OUT}) Output Offset, V_{OSO} , Initial			±3	±15	mV
vs Temperature	T_{MIN} to T_{MAX}		±2		$\mu\text{V}/^\circ\text{C}$
Full-Scale Output (FSO)	$V_S = \pm 5\text{V}$	(V-) + 1.2		(V+) - 1.5	V
Short-Circuit Current			±18		mA

ELECTRICAL CHARACTERISTICS (Cont.)

Boldface limits apply over the specified temperature range, $T_A = -5^{\circ}\text{C}$ to $+75^{\circ}\text{C}$.

At $T_A = +25^{\circ}\text{C}$, $V_S = \pm 5\text{V}$, $R_L = 10\text{k}\Omega$, unless otherwise noted.

PARAMETER	CONDITION	LOG104AID			UNITS	
		MIN	TYP	MAX		
TOTAL ERROR ⁽⁴⁾⁽⁵⁾ Initial	I_1 or I_2 remains fixed while other varies. Min to Max					
	I_1 or $I_2 = 3.5\text{mA}$			± 75	mV	
	I_1 or $I_2 = 1\text{mA}$			± 20	mV	
	I_1 or $I_2 = 100\mu\text{A}$			± 20	mV	
	I_1 or $I_2 = 10\mu\text{A}$			± 20	mV	
	I_1 or $I_2 = 1\mu\text{A}$			± 20	mV	
	I_1 or $I_2 = 100\text{nA}$			± 20	mV	
	I_1 or $I_2 = 10\text{nA}$			± 20	mV	
	I_1 or $I_2 = 1\text{nA}$			± 20	mV	
	I_1 or $I_2 = 350\text{pA}$			± 20	mV	
	I_1 or $I_2 = 100\text{pA}$			± 20	mV	
	vs Temperature	I_1 or $I_2 = 3.5\text{mA}$		± 1.2		mV/°C
		I_1 or $I_2 = 1\text{mA}$		± 0.4		mV/°C
		I_1 or $I_2 = 100\mu\text{A}$		± 0.1		mV/°C
		I_1 or $I_2 = 10\mu\text{A}$		± 0.05		mV/°C
		I_1 or $I_2 = 1\mu\text{A}$		± 0.05		mV/°C
		I_1 or $I_2 = 100\text{nA}$		± 0.09		mV/°C
		I_1 or $I_2 = 10\text{nA}$		± 0.2		mV/°C
		I_1 or $I_2 = 1\text{nA}$		± 0.3		mV/°C
		I_1 or $I_2 = 350\text{pA}$		± 0.1		mV/°C
I_1 or $I_2 = 100\text{pA}$			± 0.3		mV/°C	
vs Supply	I_1 or $I_2 = 3.5\text{mA}$		± 3.0		mV/V	
	I_1 or $I_2 = 1\text{mA}$		± 0.1		mV/V	
	I_1 or $I_2 = 100\mu\text{A}$		± 0.1		mV/V	
	I_1 or $I_2 = 10\mu\text{A}$		± 0.1		mV/V	
	I_1 or $I_2 = 1\mu\text{A}$		± 0.1		mV/V	
	I_1 or $I_2 = 100\text{nA}$		± 0.1		mV/V	
	I_1 or $I_2 = 10\text{nA}$		± 0.1		mV/V	
	I_1 or $I_2 = 1\text{nA}$		± 0.25		mV/V	
	I_1 or $I_2 = 350\text{pA}$		± 0.1		mV/V	
	I_1 or $I_2 = 100\text{pA}$		± 0.1		mV/V	
FREQUENCY RESPONSE, CORE LOG ⁽⁶⁾ BW, 3dB	$I_2 = 10\text{nA}$	$C_C = 4500\text{pF}$	0.1		kHz	
	$I_2 = 1\mu\text{A}$	$C_C = 150\text{pF}$	38		kHz	
	$I_2 = 10\mu\text{A}$	$C_C = 150\text{pF}$	40		kHz	
	$I_2 = 1\text{mA}$	$C_C = 50\text{pF}$	45		kHz	
	Step Response Increasing	$I_2 = 1\mu\text{A}$ to 1mA	$C_C = 150\text{pF}$	11		μs
		$I_2 = 100\text{nA}$ to $1\mu\text{A}$	$C_C = 150\text{pF}$	7		μs
	Decreasing	$I_2 = 10\text{nA}$ to 100nA	$C_C = 150\text{pF}$	110		μs
		$I_2 = 1\text{mA}$ to $1\mu\text{A}$	$C_C = 150\text{pF}$	45		μs
	$I_2 = 1\mu\text{A}$ to 100nA	$C_C = 150\text{pF}$	20		μs	
	$I_2 = 100\text{nA}$ to 10nA	$C_C = 150\text{pF}$	550		μs	
POWER SUPPLY	Operating Range	V_S	± 4.5	± 18	V	
	Quiescent Current	$I_O = 0$		± 1.5	mA	
TEMPERATURE RANGE	Specified Range, T_{MIN} to T_{MAX}		-5	75	°C	
	Operating Range		-40	85	°C	
	Storage Range		-55	125	°C	
	Thermal Resistance, θ_{JA} SO-8			150	°C/W	

NOTES: (1) Log Conformity Error is peak deviation from the best-fit straight line of V_{OUT} versus $\log(I_1/I_2)$ curve expressed as a percent of peak-to-peak full-scale.

(2) May require higher supply for full dynamic range.

(3) Output core log function is trimmed to 0.5V output per decade change of input current.

(4) Worst-case Total Error for any ratio of I_1/I_2 is the largest of the two errors, when I_1 and I_2 are considered separately.

(5) Total $I_1 + I_2$ should be kept below 4.5mA on $\pm 5\text{V}$ supply.

(6) Bandwidth (3dB) and transient response are a function of both the compensation capacitor and the level of input current.

TYPICAL CHARACTERISTICS

At $T_A = +25^\circ\text{C}$, $V_S = \pm 5\text{V}$, $R_L = 10\text{k}\Omega$, unless otherwise noted.

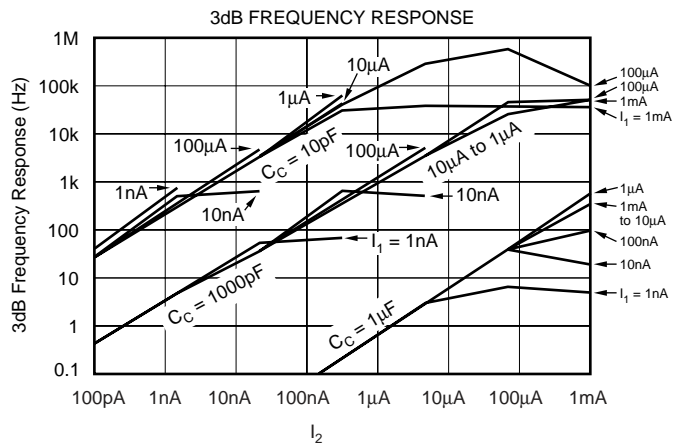
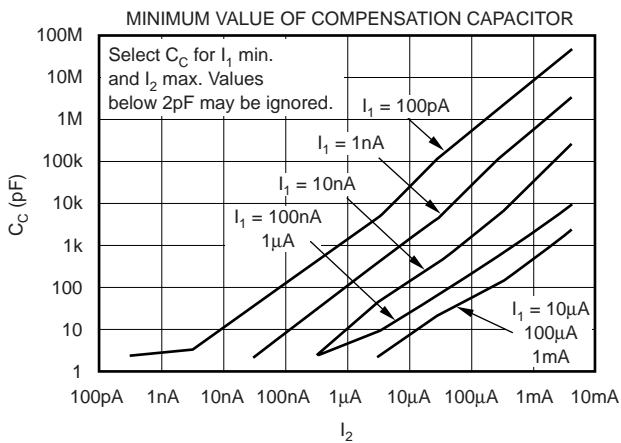
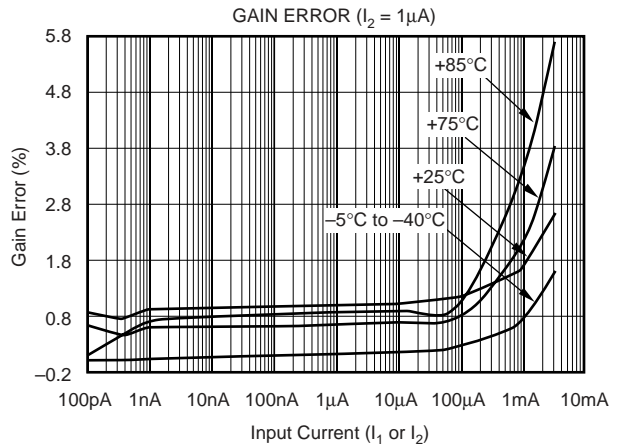
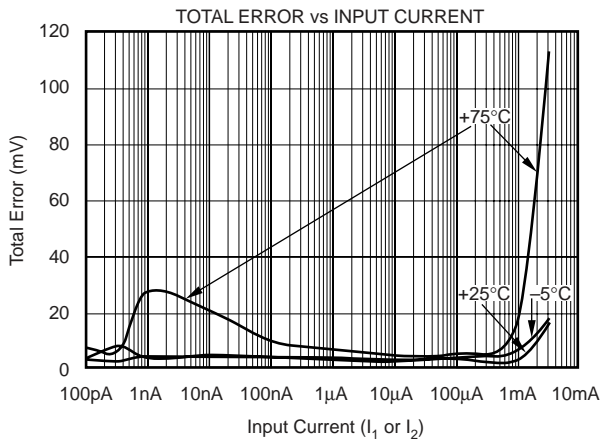
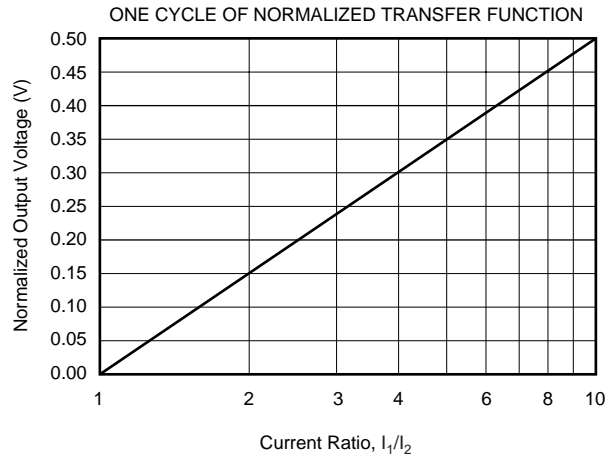
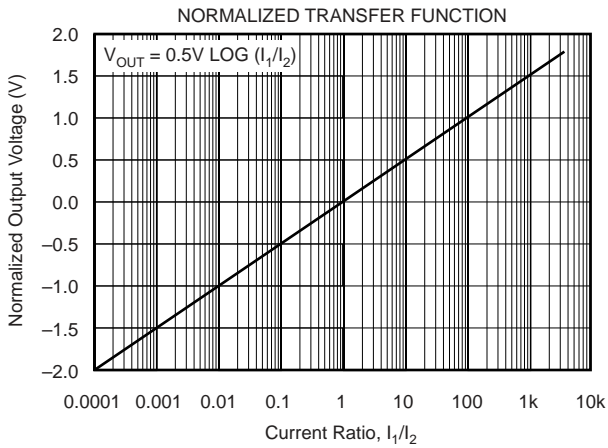

TYPICAL CHARACTERISTICS (Cont.)

At $T_A = +25^\circ\text{C}$, $V_S = \pm 5\text{V}$, $R_L = 10\text{k}\Omega$, unless otherwise noted.

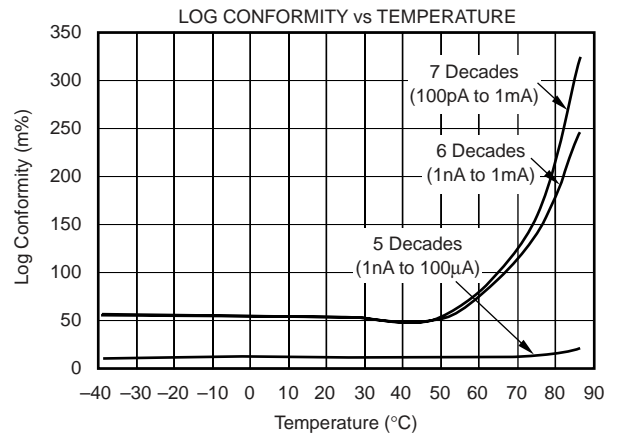
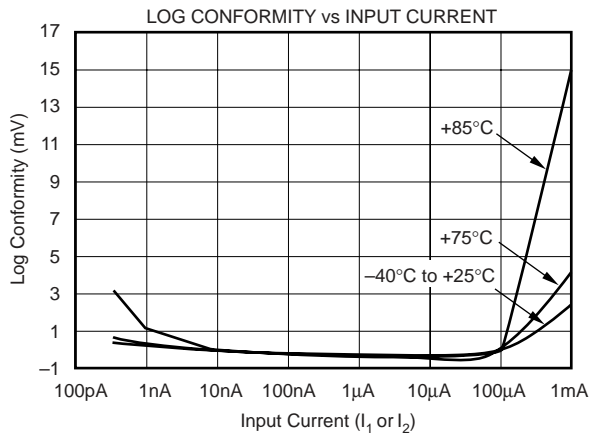

APPLICATION INFORMATION

The LOG104 is a true logarithmic amplifier that uses the base-emitter voltage relationship of bipolar transistors to compute the logarithm, or logarithmic ratio of a current ratio.

Figure 1 shows the basic connections required for operation of the LOG104. In order to reduce the influence of lead inductance of power-supply lines, it is recommended that each supply be bypassed with a $10\mu\text{F}$ tantalum capacitor in parallel with a 1000pF ceramic capacitor, as shown in Figure 1. Connecting the capacitors as close to the LOG104 as possible will contribute to noise reduction as well.

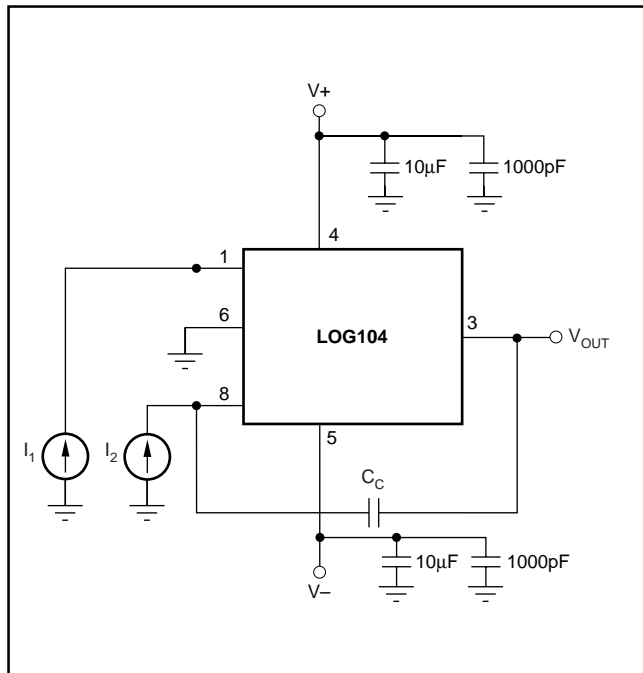

FIGURE 1. Basic Connections of the LOG104.

INPUT CURRENT RANGE

To maintain specified accuracy, the input current range of the LOG104 should be limited from 100pA to 3.5mA. Input currents outside of this range may compromise LOG104 performance. Input currents larger than 3.5mA result in increased nonlinearity. An absolute maximum input current rating of $\pm 10\text{mA}$ is included to prevent excessive power dissipation that may damage the logging transistor.

On $\pm 5\text{V}$ supplies, the total input current ($I_1 + I_2$) is limited to 4.5mA. Due to compliance issues internal to the LOG104, to accommodate larger total input currents, supplies should be increased.

Currents smaller than 100pA will result in increased errors due to the input bias currents of op amps A_1 and A_2 (typically 5pA). The input bias currents may be compensated for, as shown in Figure 2. The input stages of the amplifiers have FET inputs, with input bias current doubling every 10°C , which makes the nulling technique shown practical only where the temperature is fairly stable.

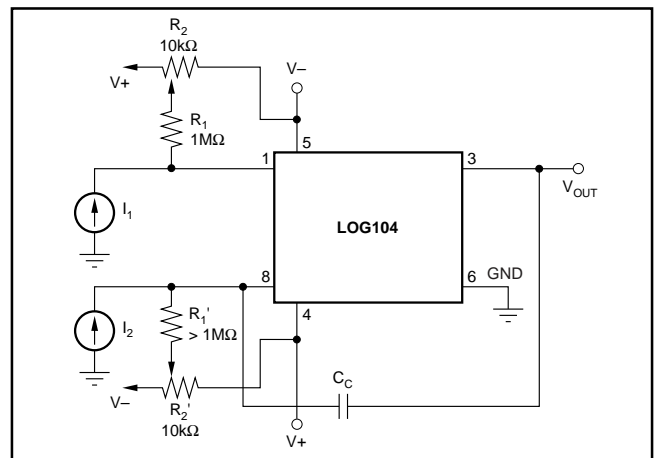

FIGURE 2. Bias Current Nulling.

SETTING THE REFERENCE CURRENT

When the LOG104 is used to compute logarithms, either I_1 or I_2 can be held constant and becomes the reference current to which the other is compared.

V_{OUT} is expressed as:

$$V_{OUT} = (0.5V) \cdot \log (I_1/I_2) \quad (1)$$

I_{REF} can be derived from an external current source (such as shown in Figure 3), or it may be derived from a voltage source with one or more resistors. When a single resistor is used, the value may be large depending on I_{REF} . If I_{REF} is 10nA and +2.5V is used:

$$R_{REF} = 2.5V/10nA = 250M \quad (2)$$

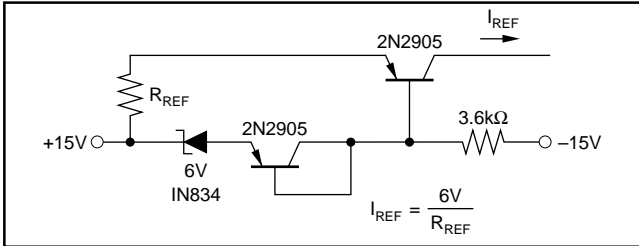

FIGURE 3. Temperature Compensated Current Source.

A voltage divider may be used to reduce the value of the resistor (as shown in Figure 4). When using this method, one must consider the possible errors caused by the amplifier's input offset voltage. The input offset voltage of amplifier A_1 has a maximum value of 1.5mV, making V_{REF} a suggested value of 100mV.

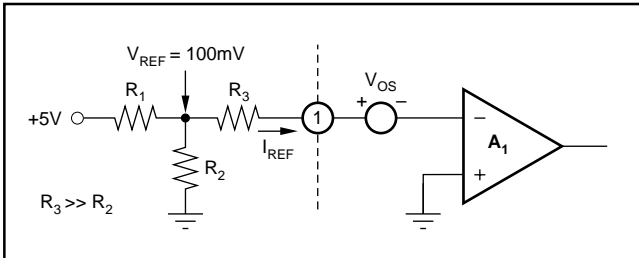

FIGURE 4. T Network for Reference Current.

Figure 5 shows a low-level current source using a series resistor. The low offset op-amp reduces the effect of the LOG104's input offset voltage.

FREQUENCY RESPONSE

The frequency response curves seen in the Typical Characteristics Curves are shown for constant DC I_1 and I_2 with a small-signal AC current on one input.

The 3dB frequency response of the LOG104 is a function of the magnitude of the input current levels and of the value of the frequency compensation capacitor. See Typical Characteristic Curve, *3dB Frequency Response* for details.

The transient response of the LOG104 is different for increasing and decreasing signals. This is due to the fact that a log amp is a nonlinear gain element and has different gains

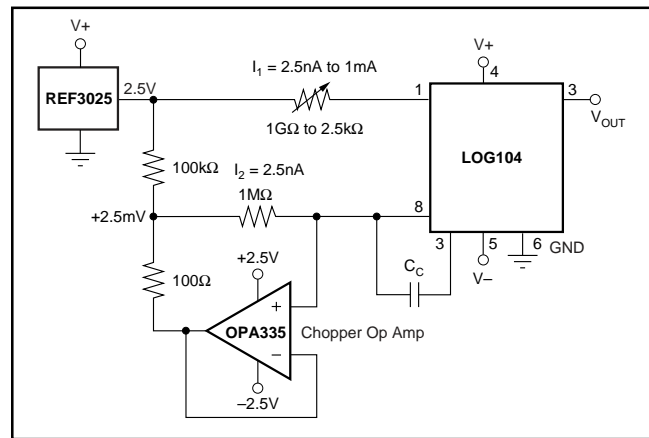

FIGURE 5. Current Source with Offset Compensation.

at different levels of input signals. Smaller input currents require greater gain to maintain full dynamic range, and will slow the frequency response of the LOG104.

FREQUENCY COMPENSATION

Frequency compensation for the LOG104 is obtained by connecting a capacitor between pins 3 and 8. The size of the capacitor is a function of the input currents, as shown in the Typical Characteristic Curves (*Minimum Value of Compensation Capacitor*). For any given application, the smallest value of the capacitor which may be used is determined by the maximum value of I_2 and the minimum value of I_1 . Larger values of C_C will make the LOG104 more stable, but will reduce the frequency response.

In an application, highest overall bandwidth can be achieved by detecting the signal level at V_{OUT} , then switching in appropriate values of compensation capacitors.

NEGATIVE INPUT CURRENTS

The LOG104 will function only with positive input currents (conventional current flows into pins 1 and 8). In situations where negative input currents are needed, the circuits in Figures 6, 7, and 8 may be used.

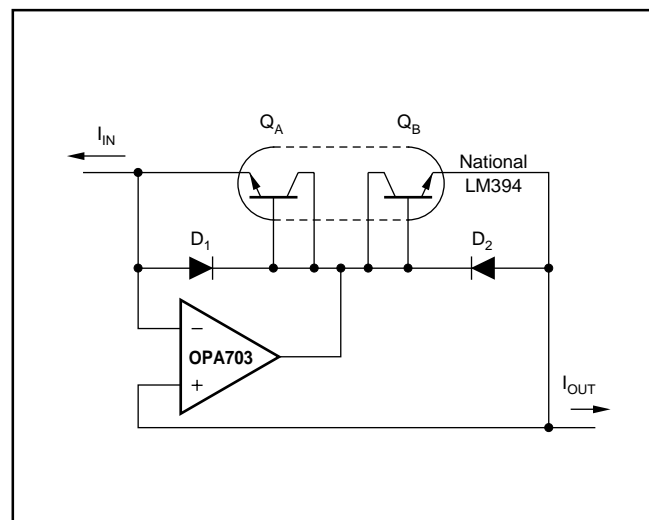

FIGURE 6. Current Inverter/Current Source.

VOLTAGE INPUTS

The LOG104 gives the best performance with current inputs. Voltage inputs may be handled directly with series resistors, but the dynamic input range is limited to approximately three decades of input voltage by voltage noise and offsets. The transfer function of Equation (13) applies to this configuration.

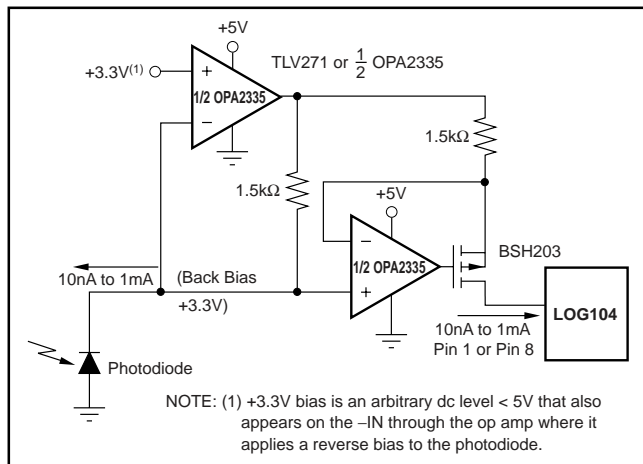

FIGURE 7. Precision Current Inverter/Current Source.

APPLICATION CIRCUITS

LOG RATIO

One of the more common uses of log ratio amplifiers is to measure absorbance. A typical application is shown in Figure 9.

$$\text{Absorbance of the sample is } A = \log \lambda_1' / \lambda_1 \quad (3)$$

$$\text{If } D_1 \text{ and } D_2 \text{ are matched } A \propto (0.5V) \log I_1 / I_2 \quad (4)$$

DATA COMPRESSION

In many applications the compressive effects of the logarithmic transfer function are useful. For example, a LOG104 preceding a 12-bit A/D converter can produce the dynamic range equivalent to a 20-bit converter.

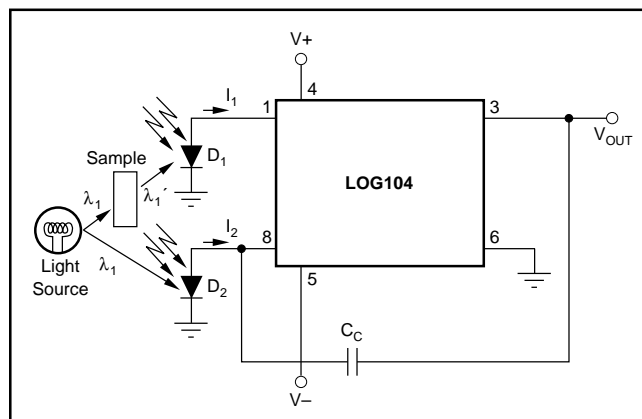

FIGURE 9. Absorbance Measurement.

OPERATION ON SINGLE SUPPLY

Many applications do not have the dual supplies required to operate the LOG104. Figure 10 shows the LOG104 configured for operation with a single +5V supply.

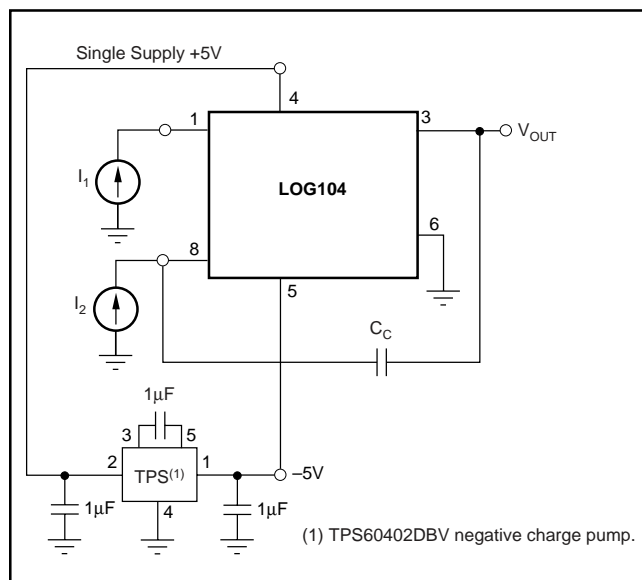

FIGURE 10. Single +5V Power-Supply Operation.

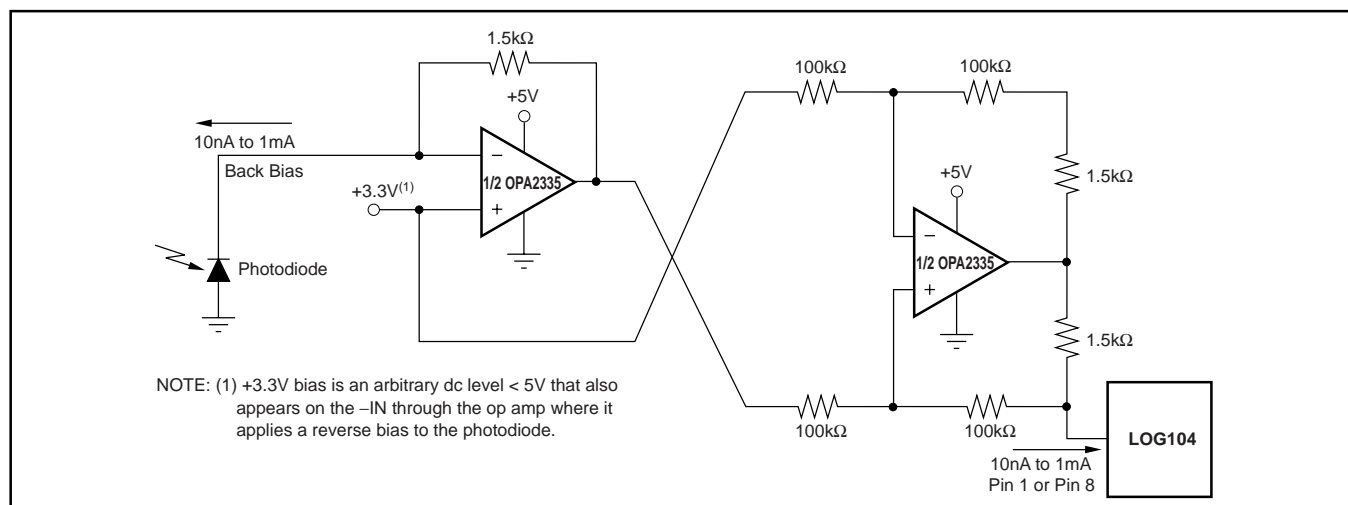

FIGURE 8. Precision Current Inverter/Current Source.

INSIDE THE LOG104

Using the base-emitter voltage relationship of matched bipolar transistors, the LOG104 establishes a logarithmic function of input current ratios. Beginning with the base-emitter voltage defined as:

$$V_{BE} = V_T \ln \frac{I_C}{I_S} \quad \text{where: } V_T = \frac{kT}{q} \quad (1)$$

k = Boltzmann's constant = $1.381 \cdot 10^{-23}$

T = Absolute temperature in degrees Kelvin

q = Electron charge = $1.602 \cdot 10^{-19}$ Coulombs

I_C = Collector current

I_S = Reverse saturation current

From the circuit in Figure 11, we see that:

$$V_L = V_{BE1} - V_{BE2} \quad (2)$$

Substituting (1) into (2) yields:

$$V_L = V_{T1} \ln \frac{I_1}{I_{S1}} - V_{T2} \ln \frac{I_2}{I_{S2}} \quad (3)$$

If the transistors are matched and isothermal and $V_{T1} = V_{T2}$, then (3) becomes:

$$V_L = V_{T1} \left[\ln \frac{I_1}{I_S} - \ln \frac{I_2}{I_S} \right] \quad (4)$$

$$V_L = V_T \ln \frac{I_1}{I_2} \quad \text{and since} \quad (5)$$

$$\ln x = 2.3 \log_{10} x \quad (6)$$

$$V_L = n V_T \log \frac{I_1}{I_2} \quad (7)$$

$$\text{where } n = 2.3 \quad (8)$$

also

$$V_{OUT} = V_L \frac{R_1 + R_2}{R_1} \quad (9)$$

$$V_{OUT} = \frac{R_1 + R_2}{R_1} n V_T \log \frac{I_1}{I_2} \quad (10)$$

or

$$V_{OUT} = 0.5V \cdot \log \frac{I_1}{I_2} \quad (11)$$

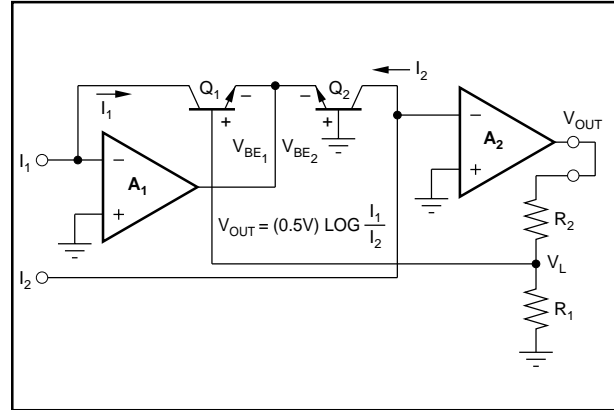

FIGURE 11. Simplified Model of a Log Amplifier.

DEFINITION OF TERMS

TRANSFER FUNCTION

The ideal transfer function is:

$$V_{OUT} = 0.5V \cdot \log_{10} I_1/I_2 \quad (5)$$

See Figure 12 for the graphical representation of the transfer over valid operating range for the LOG104.

ACCURACY

Accuracy considerations for a log ratio amplifier are somewhat more complicated than for other amplifiers. This is because the transfer function is nonlinear and has two inputs, each of which can vary over a wide dynamic range. The accuracy for any combination of inputs is determined from the total error specification.

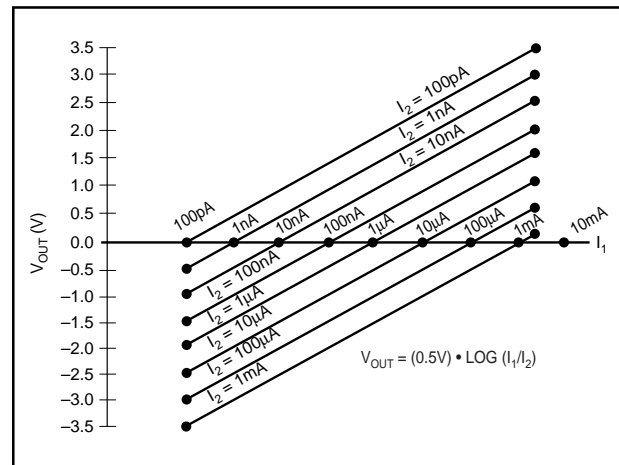

FIGURE 13. Transfer Function with Varying I_2 and I_1 .

TOTAL ERROR

The total error is the deviation (expressed in mV) of the actual output from the ideal output of $V_{OUT} = 0.5V \cdot \log(I_1/I_2)$.

Thus,

$$V_{OUT(ACTUAL)} = V_{OUT(IDEAL)} \pm \text{Total Error.} \quad (6)$$

It represents the sum of all the individual components of error normally associated with the log amp when operated in the current input mode. The worst-case error for any given ratio of I_1/I_2 is the largest of the two errors when I_1 and I_2 are considered separately. Temperature can affect total error.

ERRORS RTO AND RTI

As with any transfer function, errors generated by the function itself may be Referred-to-Output (RTO) or Referred-to-Input (RTI). In this respect, log amps have a unique property:

Given some error voltage at the log amp's output, that error corresponds to a constant percent of the input regardless of the actual input level.

MEASURING AVALANCHE PHOTODIODE CURRENT

The wide dynamic range of the LOG104 is useful for measuring avalanche photodiode current (APD), as shown in Figure 13.

LOG CONFORMITY

For the LOG104, log conformity is calculated the same as linearity and is plotted I_1/I_2 on a semi-log scale. In many applications, log conformity is the most important specification. This is true because bias current errors are negligible (5pA compared to input currents of 100pA and above) and the scale factor and offset errors may be trimmed to zero or removed by system calibration. This leaves log conformity as the major source of error.

Log conformity is defined as the peak deviation from the best fit straight line of the V_{OUT} versus $\log(I_1/I_2)$ curve. This is expressed as a percent of ideal full-scale output. Thus, the nonlinearity error expressed in volts over m decades is:

$$V_{OUT(NONLIN)} = 0.5V/\text{dec} \cdot 2Nm \quad (7)$$

where N is the log conformity error, in percent.

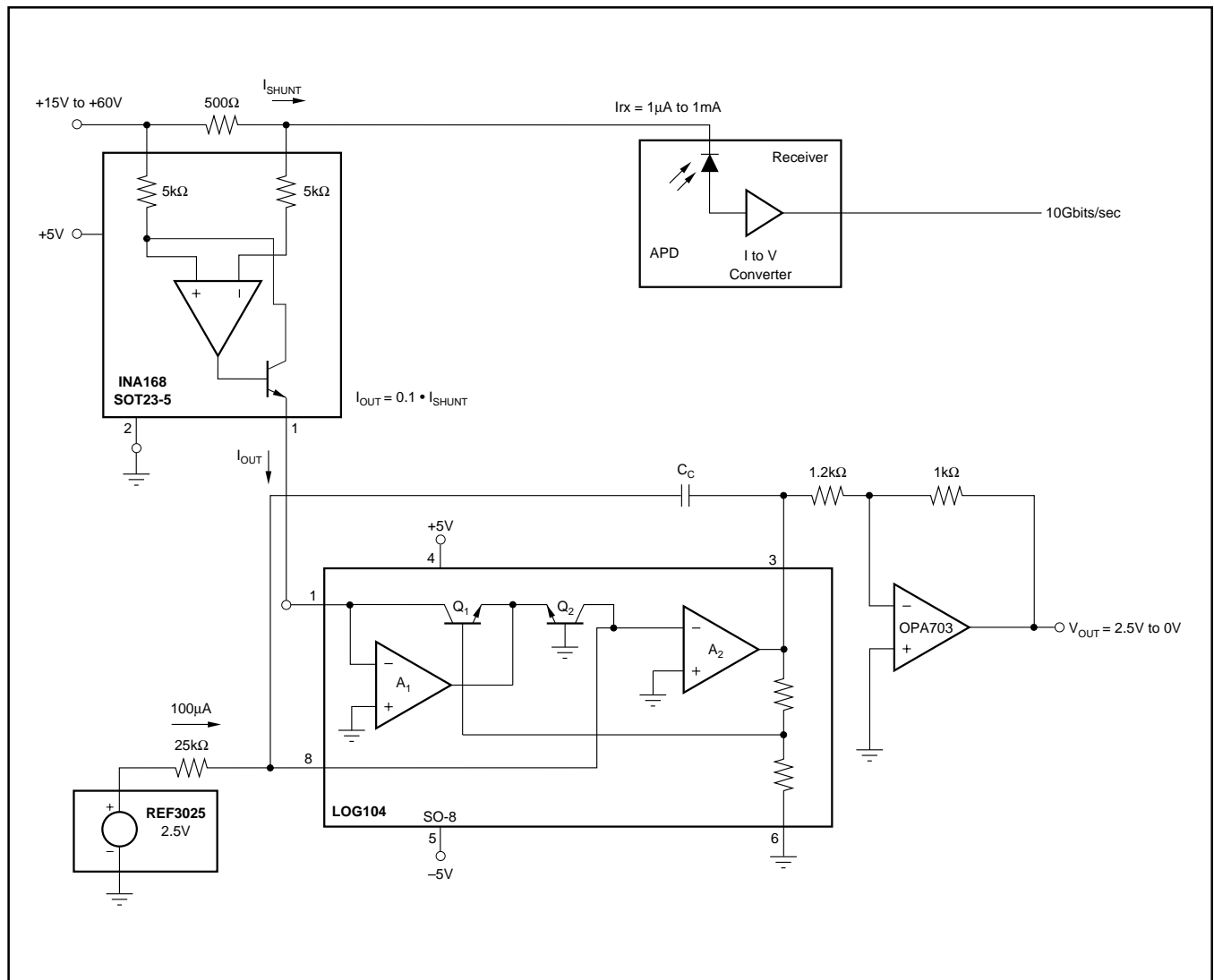

FIGURE 14. High Side Shunt for Avalanche Photodiode (APD) Measures 3-Decades of APD Current.

INDIVIDUAL ERROR COMPONENTS

The ideal transfer function with current input is:

$$V_{OUT} = (0.5V) \cdot \log \frac{I_1}{I_2} \quad (8)$$

The actual transfer function with the major components of error is:

$$V_{OUT} = (0.5V) (1 \pm \Delta K) \log \frac{I_1 - I_{B1} \pm Nm \pm V_{OSO}}{I_2 - I_{B2}} \quad (9)$$

The individual component of error is:

ΔK = gain accuracy (0.15%, typ), as specified in specification table.

I_{B1} = bias current of A_1 (5pA, typ)

I_{B2} = bias current of A_2 (5pA, typ)

N = log conformity error (0.01%, 0.06%, typ)

0.01% for $n = 5$, 0.06% for $n = 7.5$

V_{OSO} = output offset voltage (3mV, typ)

m = number of decades over which N is specified:

Example: what is the error when

$$I_1 = 1\mu\text{A} \text{ and } I_2 = 100\text{nA} \quad (10)$$

$$V_{OUT} = (0.5 \pm 0.0015) \log \frac{10^{-6} - 5 \cdot 10^{-12}}{10^{-7} - 5 \cdot 10^{-12}} \pm (2)(0.0001)5 \pm 3.0\text{mV} \\ = 0.5055V \quad (11)$$

Since the ideal output is 0.5V, the error as a percent of reading is

$$\% \text{ error} = \frac{0.5055}{0.5} \cdot 100\% = 1.1\% \quad (12)$$

For the case of voltage inputs, the actual transfer function is

$$V_{OUT} = (0.5V) (1 \pm \Delta K) \log \frac{\frac{V_1 - I_{B1} \pm \frac{E_{OS1}}{R_1}}{\frac{V_2 - I_{B2} \pm \frac{E_{OS2}}{R_2}}}}{\pm Nm \pm V_{OSO}} \quad (13)$$

Where $\frac{E_{OS1}}{R_1}$ and $\frac{E_{OS2}}{R_2}$ are considered to be zero for large values of resistance from external input current sources.

PACKAGING INFORMATION

Orderable Device	Status (1)	Package Type	Package Drawing	Pins	Package Qty	Eco Plan (2)	Lead/Ball Finish (6)	MSL Peak Temp (3)	Op Temp (°C)	Device Marking (4/5)	Samples
LOG104AID	ACTIVE	SOIC	D	8	75	Green (RoHS & no Sb/Br)	NIPDAU	Level-3-260C-168 HR	-40 to 85	LOG 104A	Samples
LOG104AIDE4	ACTIVE	SOIC	D	8	75	Green (RoHS & no Sb/Br)	NIPDAU	Level-3-260C-168 HR	-40 to 85	LOG 104A	Samples

(1) The marketing status values are defined as follows:

ACTIVE: Product device recommended for new designs.

LIFEBUY: TI has announced that the device will be discontinued, and a lifetime-buy period is in effect.

NRND: Not recommended for new designs. Device is in production to support existing customers, but TI does not recommend using this part in a new design.

PREVIEW: Device has been announced but is not in production. Samples may or may not be available.

OBSELETE: TI has discontinued the production of the device.

(2) **RoHS:** TI defines "RoHS" to mean semiconductor products that are compliant with the current EU RoHS requirements for all 10 RoHS substances, including the requirement that RoHS substance do not exceed 0.1% by weight in homogeneous materials. Where designed to be soldered at high temperatures, "RoHS" products are suitable for use in specified lead-free processes. TI may reference these types of products as "Pb-Free".

RoHS Exempt: TI defines "RoHS Exempt" to mean products that contain lead but are compliant with EU RoHS pursuant to a specific EU RoHS exemption.

Green: TI defines "Green" to mean the content of Chlorine (Cl) and Bromine (Br) based flame retardants meet JS709B low halogen requirements of <=1000ppm threshold. Antimony trioxide based flame retardants must also meet the <=1000ppm threshold requirement.

(3) MSL, Peak Temp. - The Moisture Sensitivity Level rating according to the JEDEC industry standard classifications, and peak solder temperature.

(4) There may be additional marking, which relates to the logo, the lot trace code information, or the environmental category on the device.

(5) Multiple Device Markings will be inside parentheses. Only one Device Marking contained in parentheses and separated by a "~" will appear on a device. If a line is indented then it is a continuation of the previous line and the two combined represent the entire Device Marking for that device.

(6) Lead/Ball Finish - Orderable Devices may have multiple material finish options. Finish options are separated by a vertical ruled line. Lead/Ball Finish values may wrap to two lines if the finish value exceeds the maximum column width.

Important Information and Disclaimer:The information provided on this page represents TI's knowledge and belief as of the date that it is provided. TI bases its knowledge and belief on information provided by third parties, and makes no representation or warranty as to the accuracy of such information. Efforts are underway to better integrate information from third parties. TI has taken and continues to take reasonable steps to provide representative and accurate information but may not have conducted destructive testing or chemical analysis on incoming materials and chemicals. TI and TI suppliers consider certain information to be proprietary, and thus CAS numbers and other limited information may not be available for release.

In no event shall TI's liability arising out of such information exceed the total purchase price of the TI part(s) at issue in this document sold by TI to Customer on an annual basis.

D0008A



PACKAGE OUTLINE

SOIC - 1.75 mm max height

SMALL OUTLINE INTEGRATED CIRCUIT



4214825/C 02/2019

NOTES:

1. Linear dimensions are in inches [millimeters]. Dimensions in parenthesis are for reference only. Controlling dimensions are in inches. Dimensioning and tolerancing per ASME Y14.5M.
2. This drawing is subject to change without notice.
3. This dimension does not include mold flash, protrusions, or gate burrs. Mold flash, protrusions, or gate burrs shall not exceed .006 [0.15] per side.
4. This dimension does not include interlead flash.
5. Reference JEDEC registration MS-012, variation AA.

EXAMPLE BOARD LAYOUT

D0008A

SOIC - 1.75 mm max height

SMALL OUTLINE INTEGRATED CIRCUIT

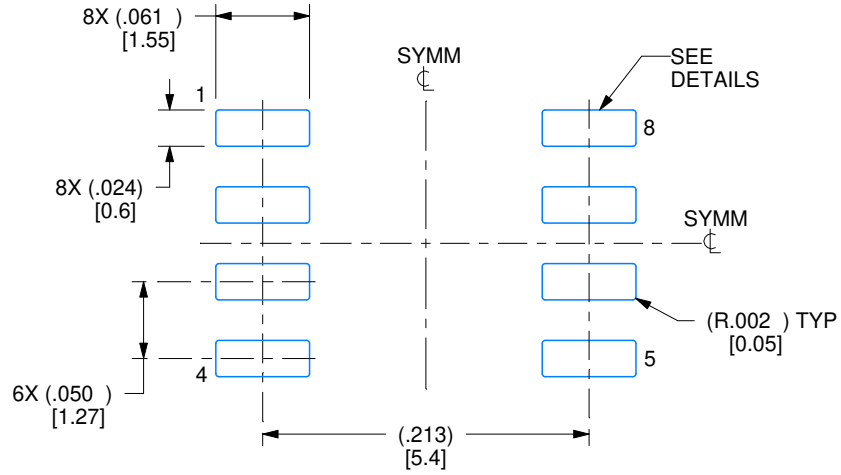

LAND PATTERN EXAMPLE
EXPOSED METAL SHOWN
SCALE:8X



SOLDER MASK DETAILS

4214825/C 02/2019

NOTES: (continued)

- 6. Publication IPC-7351 may have alternate designs.
- 7. Solder mask tolerances between and around signal pads can vary based on board fabrication site.

EXAMPLE STENCIL DESIGN

D0008A

SOIC - 1.75 mm max height

SMALL OUTLINE INTEGRATED CIRCUIT

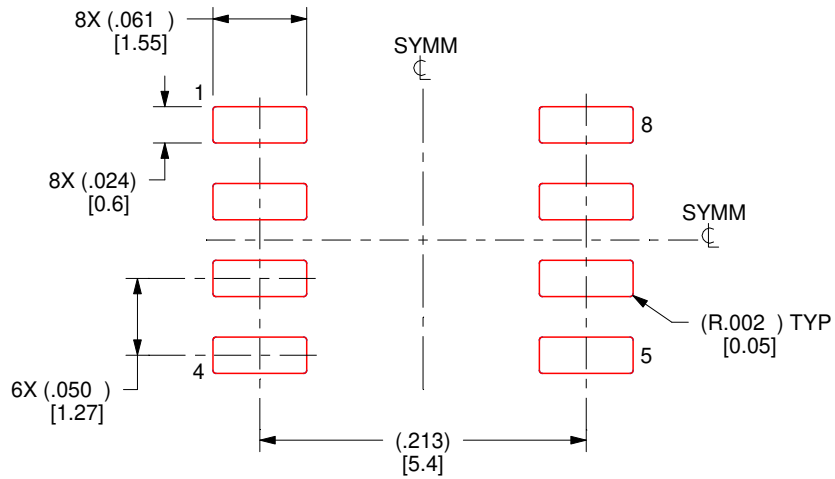

SOLDER PASTE EXAMPLE
BASED ON .005 INCH [0.125 MM] THICK STENCIL
SCALE:8X

4214825/C 02/2019

NOTES: (continued)

8. Laser cutting apertures with trapezoidal walls and rounded corners may offer better paste release. IPC-7525 may have alternate design recommendations.
9. Board assembly site may have different recommendations for stencil design.

IMPORTANT NOTICE AND DISCLAIMER

TI PROVIDES TECHNICAL AND RELIABILITY DATA (INCLUDING DATASHEETS), DESIGN RESOURCES (INCLUDING REFERENCE DESIGNS), APPLICATION OR OTHER DESIGN ADVICE, WEB TOOLS, SAFETY INFORMATION, AND OTHER RESOURCES "AS IS" AND WITH ALL FAULTS, AND DISCLAIMS ALL WARRANTIES, EXPRESS AND IMPLIED, INCLUDING WITHOUT LIMITATION ANY IMPLIED WARRANTIES OF MERCHANTABILITY, FITNESS FOR A PARTICULAR PURPOSE OR NON-INFRINGEMENT OF THIRD PARTY INTELLECTUAL PROPERTY RIGHTS.

These resources are intended for skilled developers designing with TI products. You are solely responsible for (1) selecting the appropriate TI products for your application, (2) designing, validating and testing your application, and (3) ensuring your application meets applicable standards, and any other safety, security, or other requirements. These resources are subject to change without notice. TI grants you permission to use these resources only for development of an application that uses the TI products described in the resource. Other reproduction and display of these resources is prohibited. No license is granted to any other TI intellectual property right or to any third party intellectual property right. TI disclaims responsibility for, and you will fully indemnify TI and its representatives against, any claims, damages, costs, losses, and liabilities arising out of your use of these resources.

TI's products are provided subject to TI's Terms of Sale (www.ti.com/legal/termsofsale.html) or other applicable terms available either on ti.com or provided in conjunction with such TI products. TI's provision of these resources does not expand or otherwise alter TI's applicable warranties or warranty disclaimers for TI products.

Mailing Address: Texas Instruments, Post Office Box 655303, Dallas, Texas 75265
Copyright © 2020, Texas Instruments Incorporated