

| | | | |
|--------------------|---|-------------|---|
| PART NUMBER | SML-LX2832SOC-TR | REV | F |
| REV | E.C.N NUMBER AND REVISION COMMENTS | DATE | |
| A | E.C.N. #10967. | 03.14.03 | |
| B | E.C.N. #11450. | 02.08.05 | |
| C | E.C.N. #11627. | 10.16.07 | |
| D | E.C.N. #10BRDR. & REDRAWN / #11812. | 04.11.12 | |
| E | E.C.N. #10BRDR. | 11.12.12 | |
| F | ECN-Lumex201700133 | 12.28.17 | |

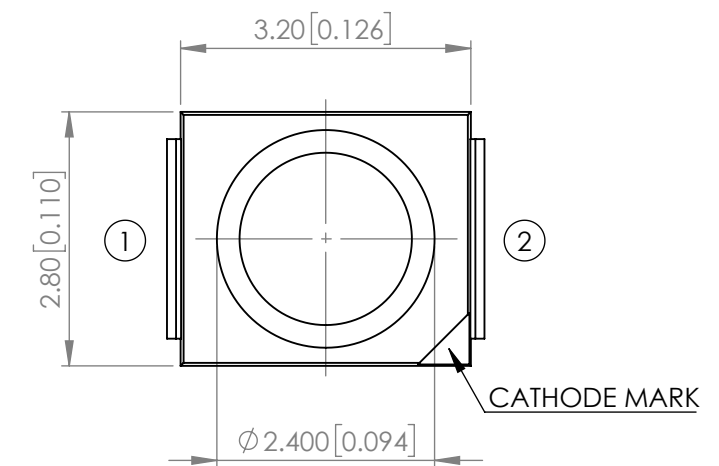

POLARITY

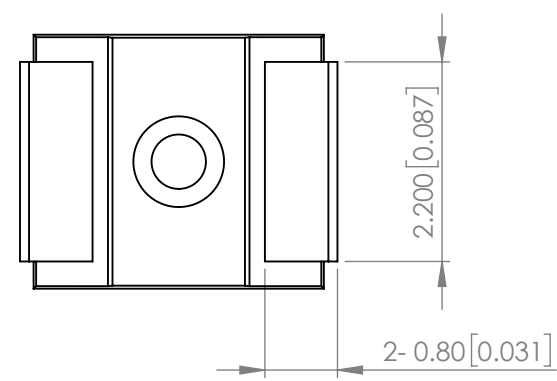
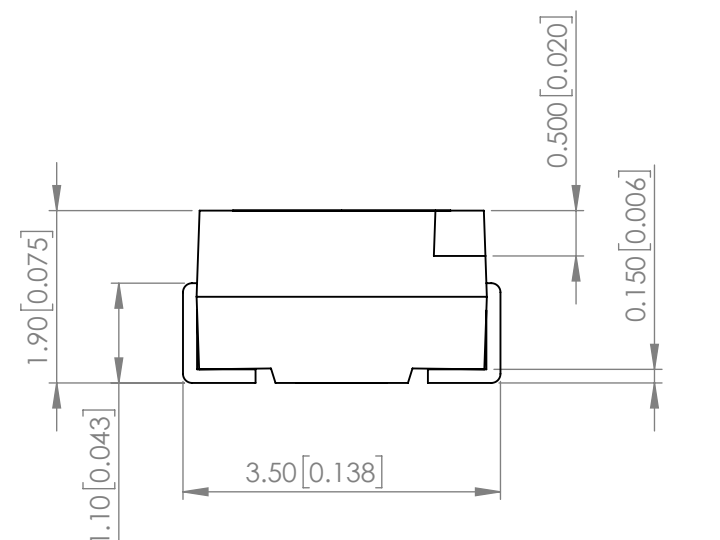
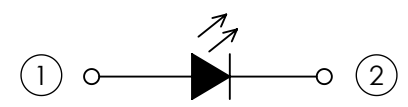

RECOMMENDED SOLDER PAD LAYOUT

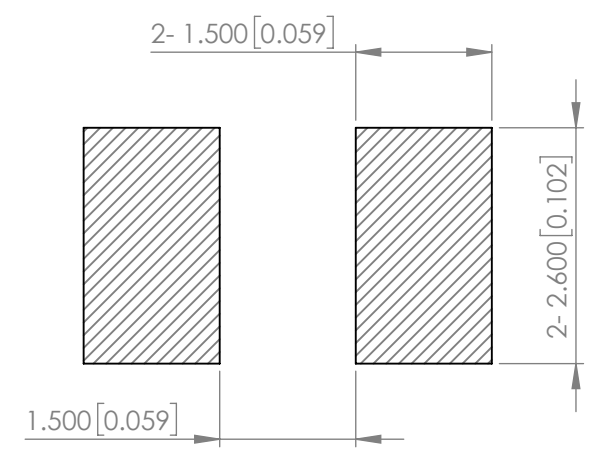

ELECTRO-OPTICAL CHARACTERISTIC TA=25°C

| PARAMETER | MIN | TYP | MAX | UNITS | TEST COND |
|--------------------|-------------|-----|-----|-------------|-----------|
| PEAK WAVELENGTH | - | 610 | - | nm | If=20mA |
| FORWARD VOLTAGE | - | 2.0 | 2.4 | Vf | If=20mA |
| REVERSE CURRENT | - | - | 10 | uA | VR=5V |
| LUMINOUS INTENSITY | - | 55 | - | mcd | If=20mA |
| VIEWING ANGLE | - | 120 | - | 2x theta1/2 | - |
| EMITTED COLOR | ORANGE | | | | |
| EPOXY LENS FINISH | WATER CLEAR | | | | |

ABSOLUTE MAXIMUM RATINGS TA=25°C

| PARAMETER | MAX | UNITS |
|-----------------------|-----------------|-------|
| PEAK FORWARD CURRENT* | 60 | mA |
| FORWARD CURRENT | 25 | mA |
| REVERSE VOLTAGE | 5 | V |
| POWER DISSIPATION | 60 | mW |
| STORAGE TEMPERATURE | -40 TO +100 | °C |
| OPERATING TEMPERATURE | -40 TO +85 | °C |
| SOLDERING TEMPERATURE | 3 SEC. MAX @260 | °C |

*t<10us

NOTE:

1. RoHS COMPLIANT.
2. PACKAGE: 2000 PCS/REEL.

**MOISTURE SENSITIVE DEVICE
PER JEDEC LEVEL 3 STANDARDS**

*UNLESS OTHERWISE SPECIFIED TOLERANCES PER DECIMAL PRECISION ARE: X=±1 (±0.039), X.X=±0.5 (±0.020), X.XX=±0.25 (±0.010), X.XXX=±0.127 (±0.005). LEAD SIZE=±0.05 (±0.002), LEAD LENGTH=±0.75 (±0.030). MIN= ^{+DECIMAL PRECISION}/_{-0.00} MAX= ^{+0.00}/_{-DECIMAL PRECISION}

PROFILE

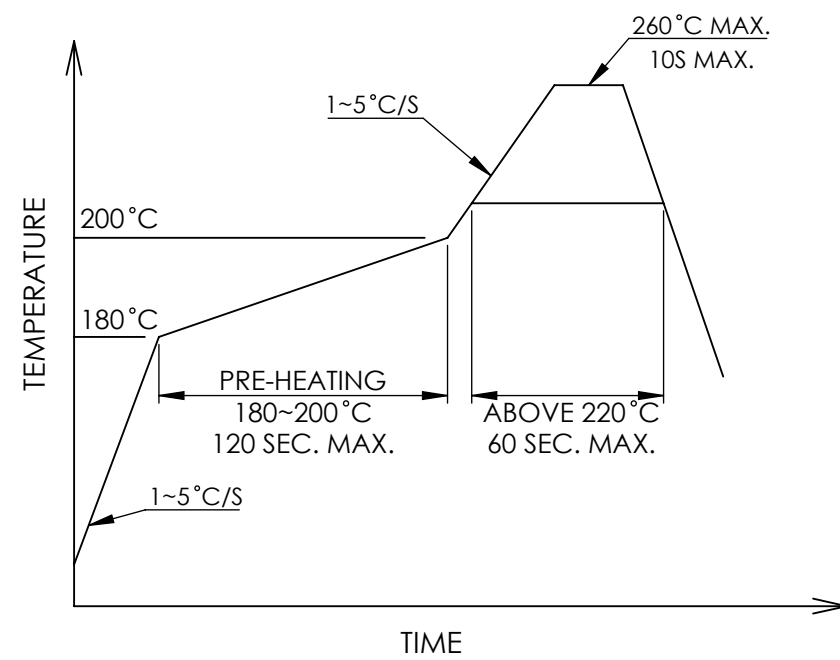

CARRIER TAPE DIMENSION

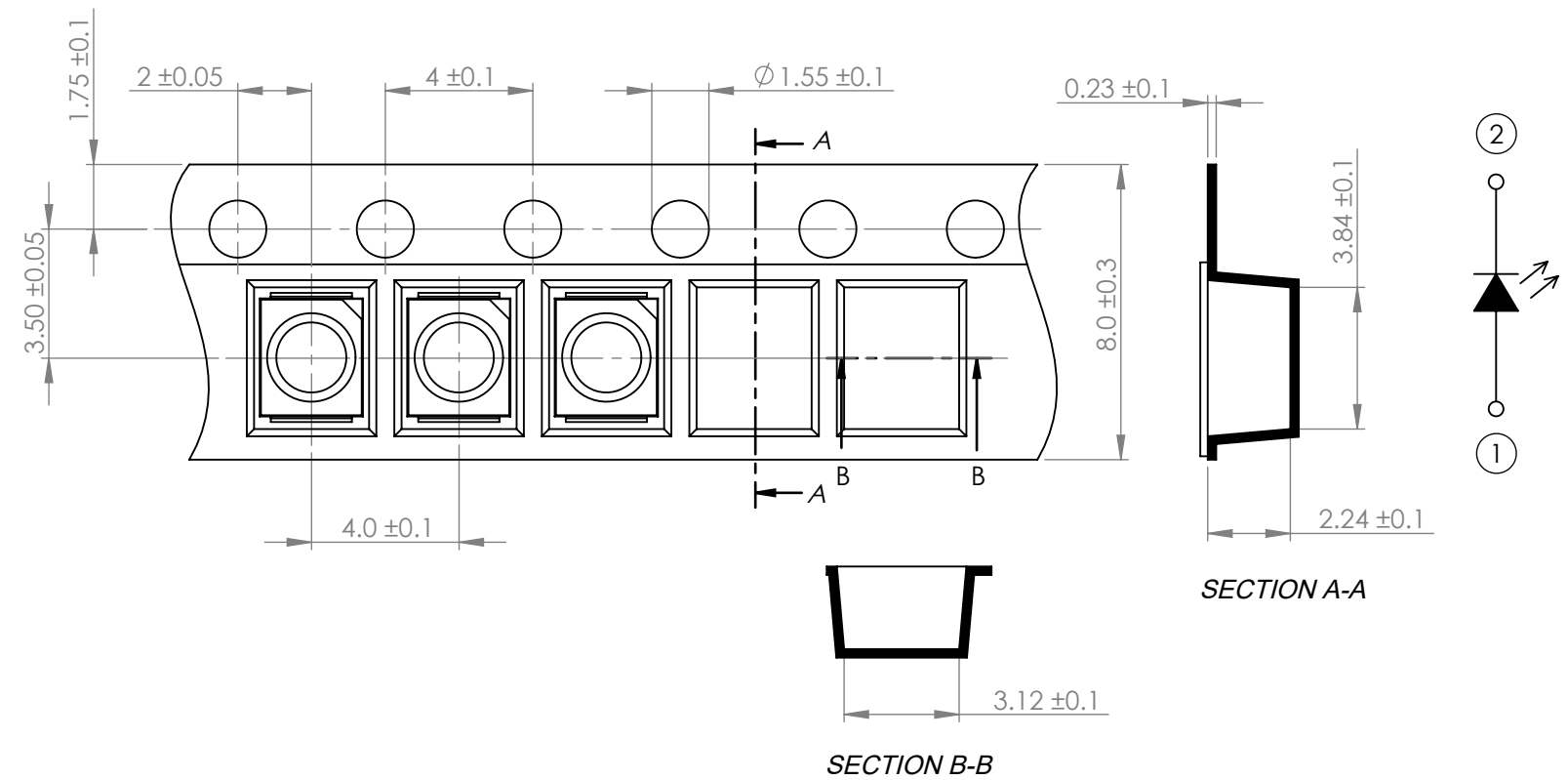

*UNLESS OTHERWISE SPECIFIED TOLERANCES PER DECIMAL PRECISION ARE: X=±1 (±0.039), X.X=±0.5 (±0.020), X.XX=±0.25 (±0.010), X.XXX=±0.127 (±0.005). LEAD SIZE=±0.05 (±0.002), LEAD LENGTH=±0.75 (±0.030). MIN= ^{+DECIMAL PRECISION} / _{-0.00} MAX.= ^{+0.00} / _{-DECIMAL PRECISION}

| | | | | |
|---|--|--|-------------------|-----------------|
|  <p>425 N. GARY AVE. CAROL STREAM, IL 60188 PHONE : 800-278-5666 FAX : 630-315-2150 WEB : WWW.LUMEX.COM</p> | 3.2(L)*2.8(W)*1.9(H)mm, SURFACE MOUNT TOP VIEW LED, 610 ORANGE, WATER CLEAR LENS, TAPE & REEL. | | DATE : 2017.12.28 | DRAWN BY : C.C. |
| | **THE SPECIFICATIONS MAY CHANGE AT ANY TIME WITHOUT NOTICE DUE TO NEW MATERIALS OR PRODUCT IMPROVEMENT.** | | PAGE : 2 OF 2 | CHKD BY : E.C. |
| | CONFIDENTIAL INFORMATION THE INFORMATION CONTAINED IN THIS DOCUMENT IS THE PROPERTY OF LUMEX INC. EXCEPT AS SPECIFICALLY AUTHORIZED IN WRITING BY LUMEX INC., THE HOLDER OF THIS DOCUMENT SHALL KEEP ALL INFORMATION CONTAINED HEREIN CONFIDENTIAL AND SHALL PROTECT SAME IN WHOLE OR IN PART FROM DISCLOSURE AND DISSEMINATION TO ALL THIRD PARTIES. | | SCALE : NTF | APRVD BY : G.Y. |
| | | | UNIT : mm [INCH] | (No) |