

REVISIONS				
REV	DESCRIPTION	DATE	BY	APP'D
R	REVISED PER ECO-21-006923	13DEC21	RK	MZ

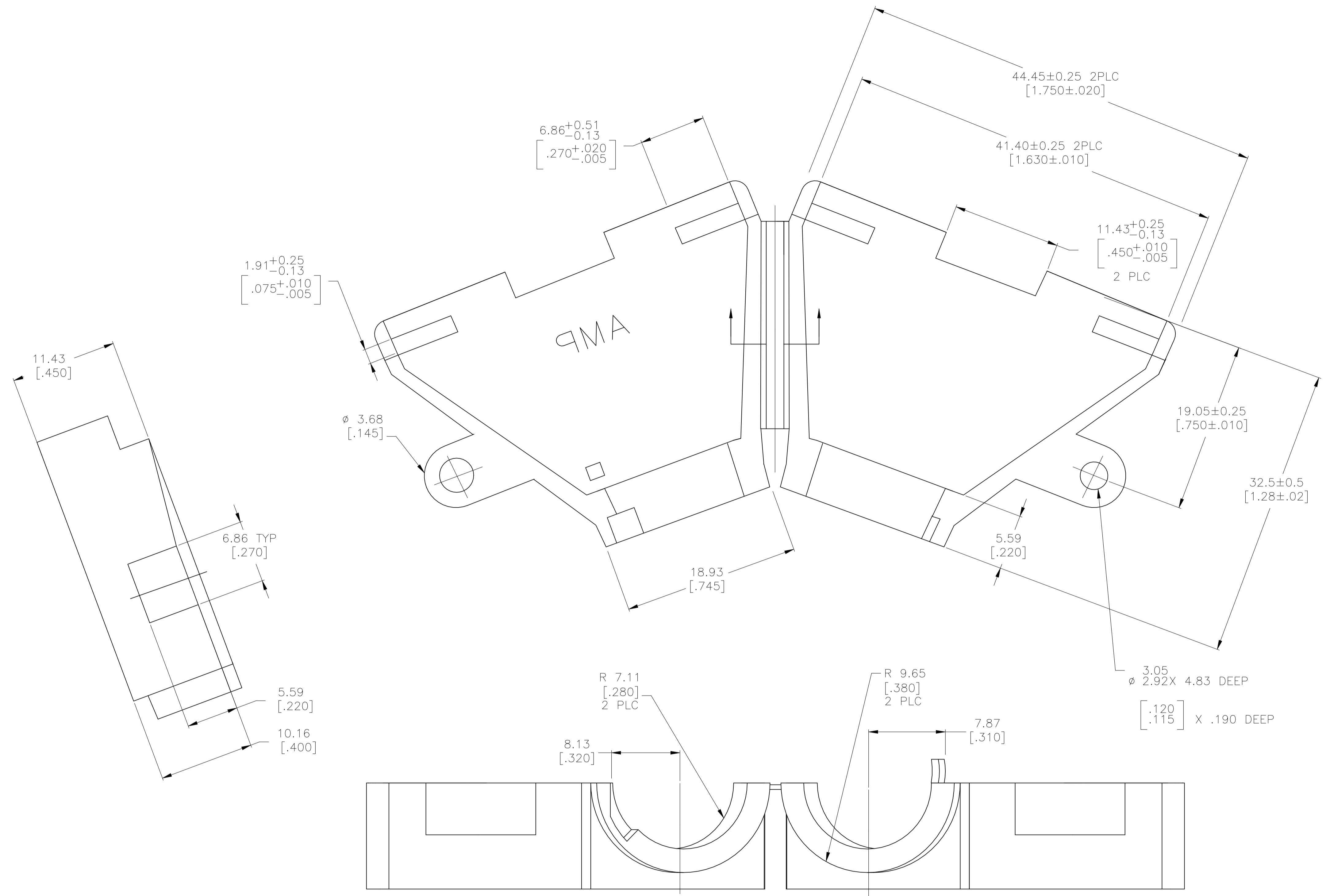

- REQUIRES A #6 PAN HEAD TYPE "B" SELF TAPPING PAN HEAD SCREW, 9.53 [.375] LONG.
- DIMENSIONS IN BRACKETS ARE IN INCHES.
- HOUSING MATERIAL: PA66, BLACK, UL 94 V-0 RATED
- HOUSING MATERIAL: PA66, BLACK, UL 94 V-2 RATED

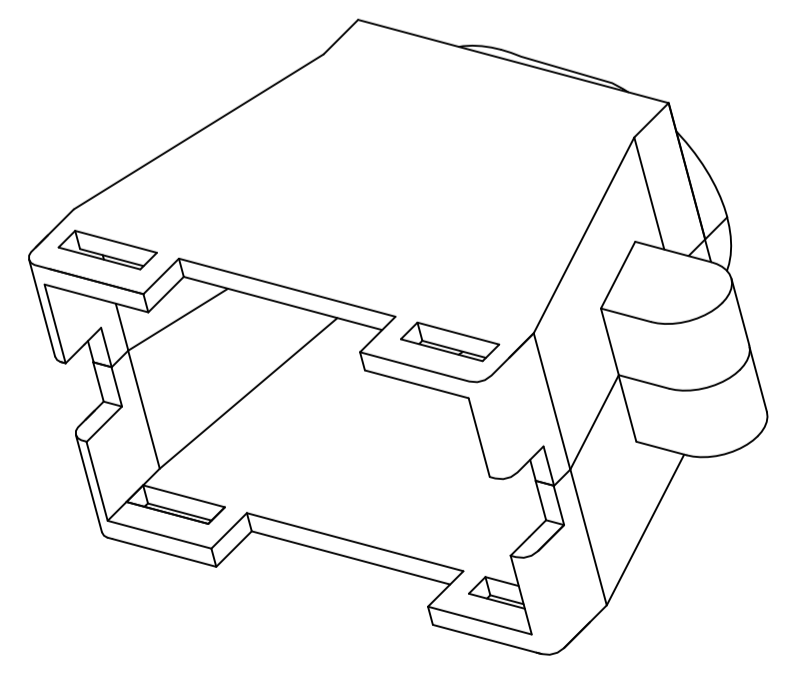
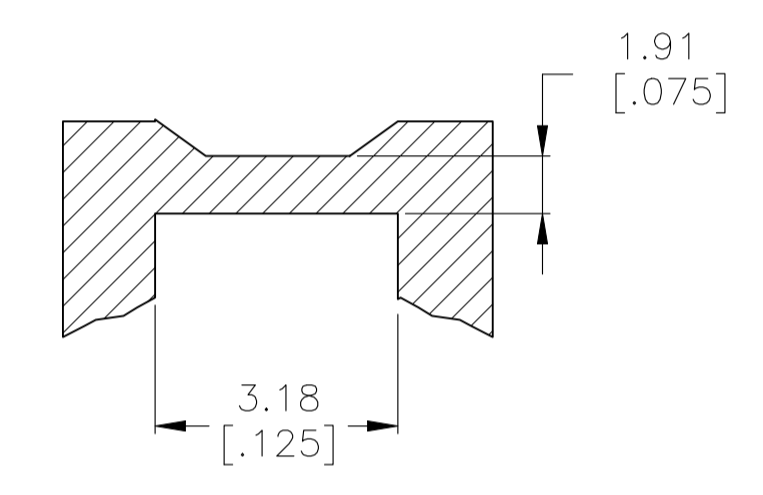

3-DIMENSIONAL MODEL NTS

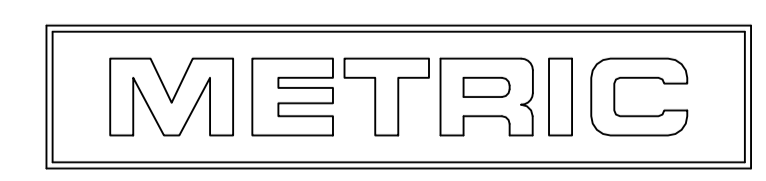

THIS DRAWING IS A CONTROLLED DOCUMENT.		DIN 9-21-93	1-480594-9	
DIMENSIONS: mm [INCHES]		K. SALMON 9-21-93		
TOLERANCES UNLESS OTHERWISE SPECIFIED:		CHK R. SWING 9-21-93		
0 PLC ± -		APVD W. LONG 7-20-94		
1 PLC ± -		PRODUCT SPEC		
2 PLC ± 0.13 [.005]		APPLICATION SPEC		
3 PLC ± -		SIZE	A1	00779
4 PLC ± -		CAGE CODE	C=480594	480594-1
ANGLES ± -		DRAWING NO	480594	36 POSITION
MATERIAL SEE TABLE	FINISH -	WEIGHT		
		CUSTOMER DRAWING	SCALE 1:1	SHEET 1 of 1