

4

3

2

1

REVISIONS			
REV.	DESCRIPTION	DATE	APPROVED
-	INITIAL RELEASE	07/03/2018	MM
1	UPDATED PART NUMBER	10/24/2018	DL
2	ADDED SHEET 2 PCB DEFINITION	2/19/2019	PV
3	CORRECTED PCB POST HOLE DIA	4/29/2019	PV
4	UPD PCB (COMMON SL AND CPW)	5/13/2019	PV
5	CHANGED PN, WAS: TMB-V5FS-2SM	1/9/2020	PV

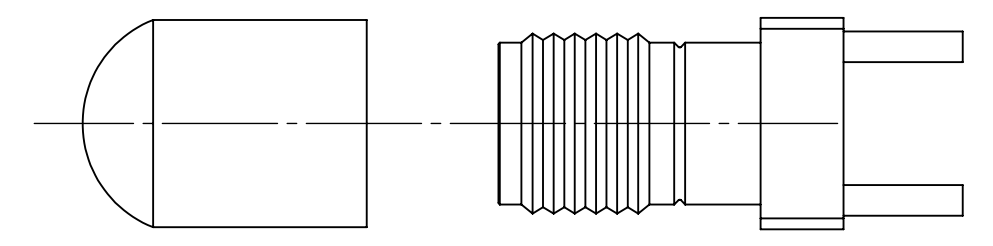
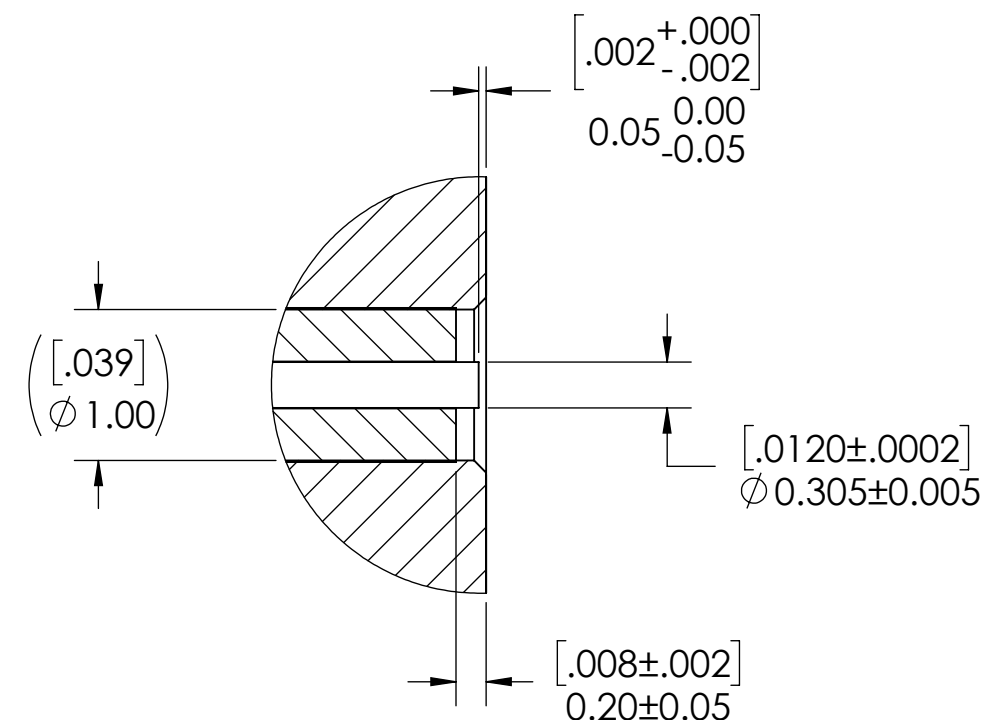
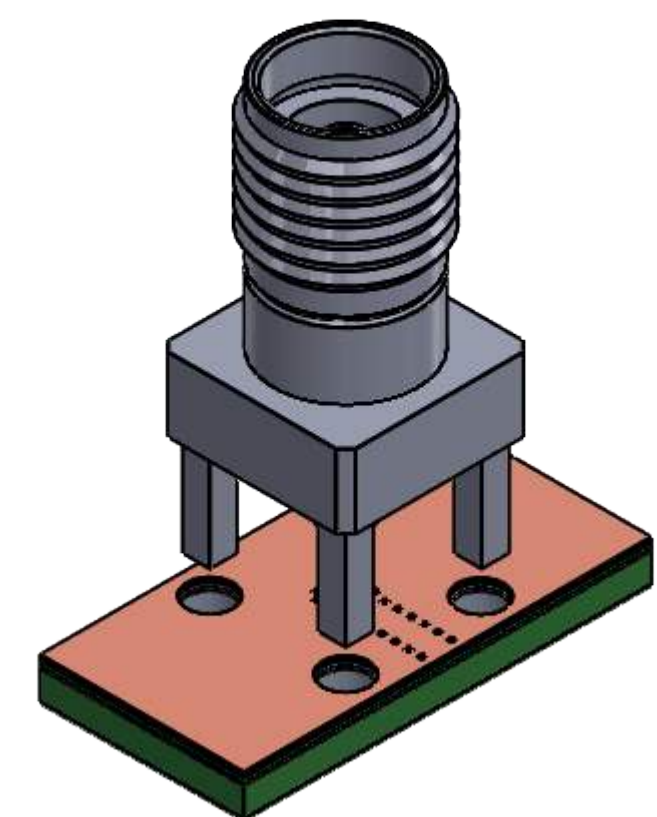
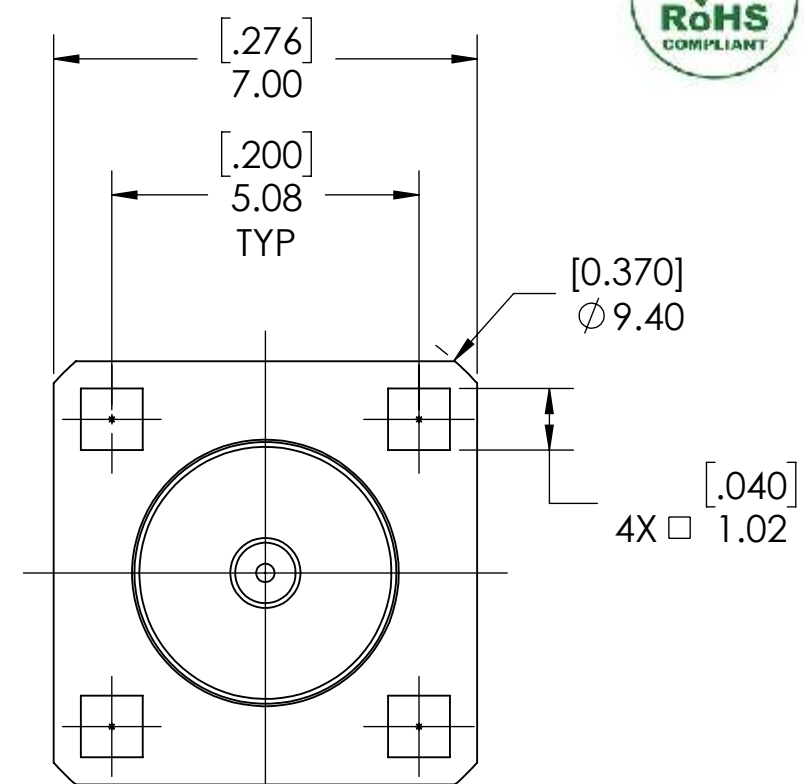
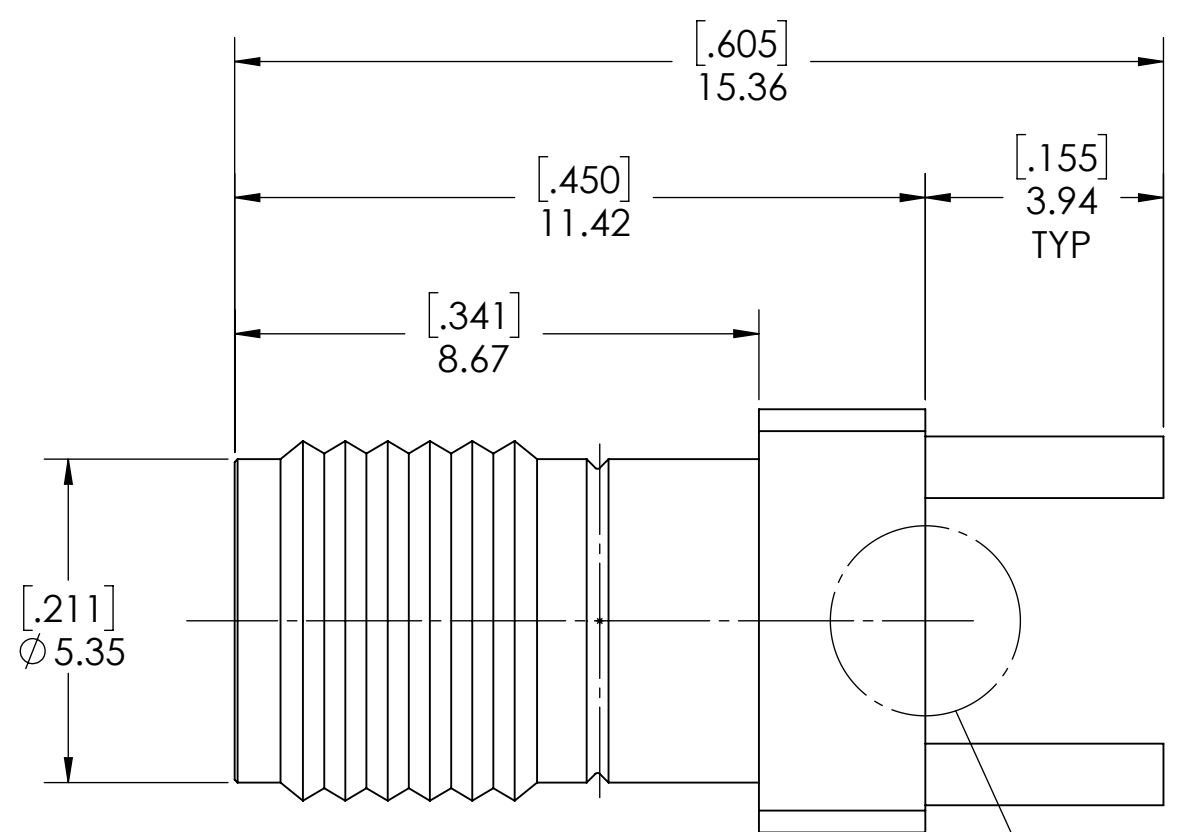
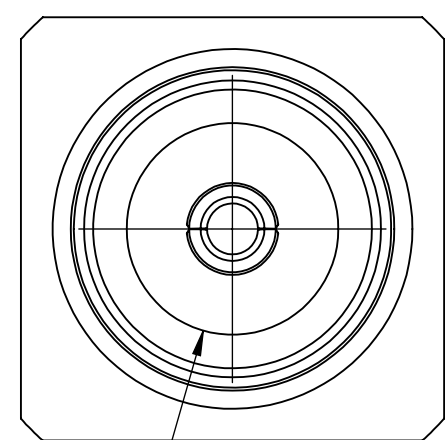

PROTECTION CAP

NOTE(S):
 1. These characteristics are typical and for reference.
 2. DYH: 58-20004-12040
 3. See sheet 2 for PCB interface definition.

MATERIAL(S):	ELECTRICAL(S):	MECHANICAL(S):	ENVIRONMENTAL(S):
Body: Brass Center Conductor: Beryllium Copper Insulator: Insulator 1: PCTFE, white Insulator 2: PTFE, white RoHS Compliant Protective Cap: Soft PVC Color: White	Impedance: 50 Ohms Nominal Frequency Range: DC to 34 GHz VSWR: 1.3:1 max at 34 GHz Working Voltage: 400 Vrms max @ Sea Level Dielectric Withstand Voltage: 500 Vrms max. Insulation Resistance: 5000 Megaohms min. Contact Resistance: Initial: Center Contact: 1.5 Milliohms max Outer Contact: 0.8 Milliohms max	Mating Characteristics: Interface per MIL-STD-348 Force to Engage & Disengage: Torque: 2 inch-pounds max Longitudinal Force: NA Connector Durability: 500 Cycles min. Permeability: Less than 2.0 mu. Center Contact Retention: Axial Force: 6 pounds min. Radial Force: NA	Temperature Range: -65°C to +165°C Moisture Resistance: MIL-STD-202, Method 103, Test Condition B Corrosion: MIL-STD-202, Method 101, Test Condition B Vibration: MIL-STD-202, Method 204, Test Condition A Shock: MIL-STD-202, Method 213, Test Condition 1

FINISH(ES):
Body: Gold Plating Center Conductor: Gold Plating

APPLICABLE CARLISLE IT DOCUMENTS		
WORK STANDARD	PROD INSTRUC	ASSY INSTRUC
NA	NA	NA

NOTICE
 THIS DRAWING EMBODIES A CONFIDENTIAL PROPRIETARY DESIGN ORIGINATED BY CARLISLE INTERCONNECT TECHNOLOGIES & ALL DESIGN, MANUFACTURING, REPRODUCTION, USE & SALE RIGHTS REGARDING THE SAME ARE EXPRESSLY RESERVED. IT IS SUBMITTED UNDER A CONFIDENTIAL RELATIONSHIP FOR A SPECIFIED PURPOSE & THE RECIPIENT AGREES BY ACCEPTING THIS DRAWING NOT SUPPLY OR DISCLOSE ANY INFORMATION REGARDING IT TO ANY UNAUTHORIZED PERSON TO INCORPORATE IN OTHER PROJECTS ANY SPECIAL FEATURES PECULIAR TO THIS DESIGN. ALL PATENT RIGHTS HERETO ARE EXPRESSLY RESERVED BY CARLISLE INTERCONNECT TECHNOLOGIES, CERRITOS, CALIFORNIA 90703.

TOLERANCES AND NOTES
EXCEPT AS NOTED
THIRD ANGLE PROJECTION
SCALE 8:1
DIMENSIONS ARE IN [INCHES] MM
ANGLES ±2°
.XX DECIMALS ±.063
.XXX DECIMALS ±.01

APPROVAL	INITIALS	DATE
DRAWN BY	MM	07.03.18
CHECKED BY	KM	07.03.18
DESIGN ENG		
APPR BY		

Dongguan City, Guangdong P.R. China 523533

TITLE: 3.50mm STRAIGHT JACK, VERTICAL SOLDER (SIGNAL PAD)

SCALE: 8:1 SUB-DIRECTORY/ _OUTLINE/ SHEET 1 OF 2

SIZE: DRAWING NO. TMB-V5FS-3SM REV. 5

4

3

2

1

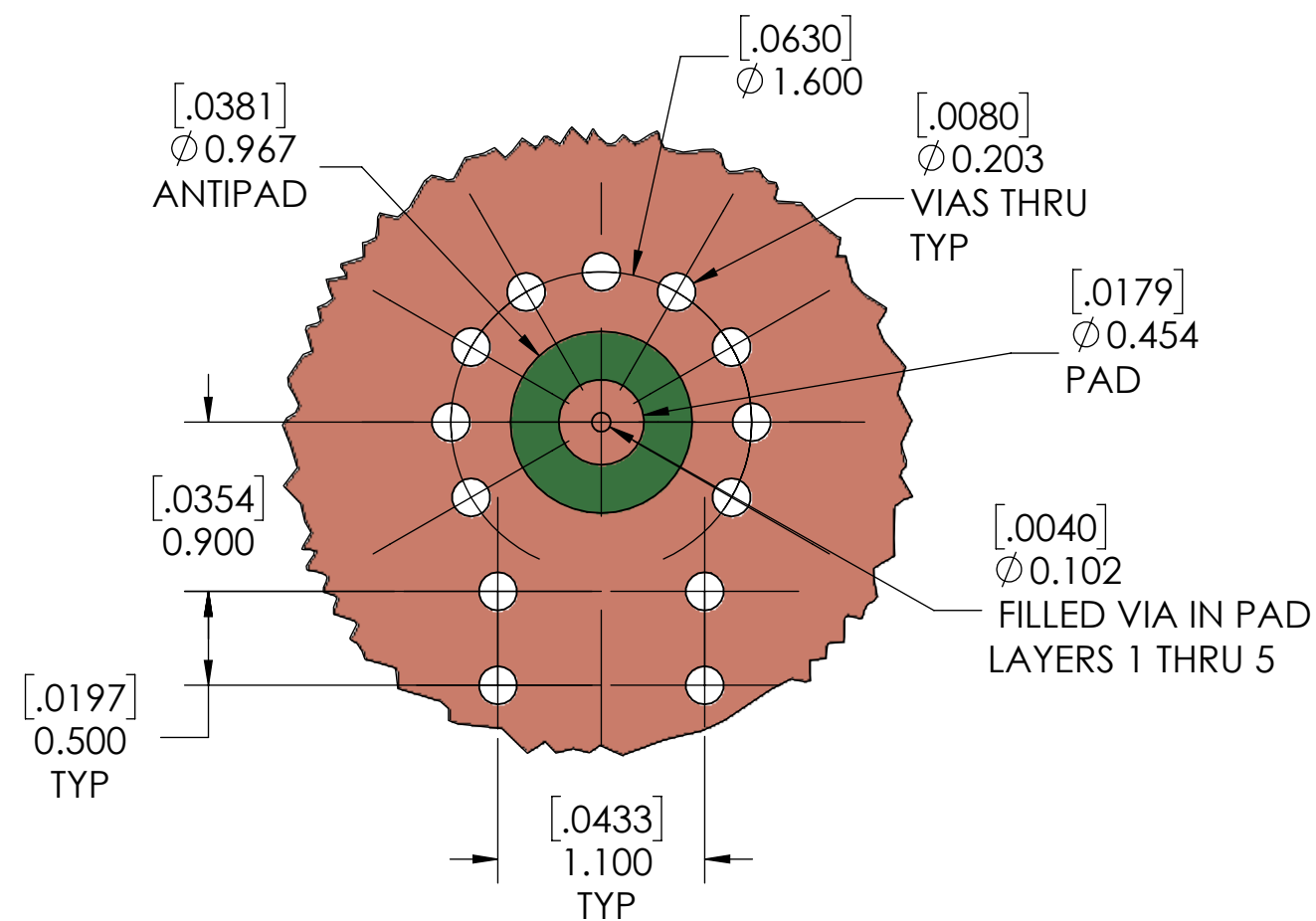

DETAIL B
SCALE 25 : 1
LAYER 1 (Cu)

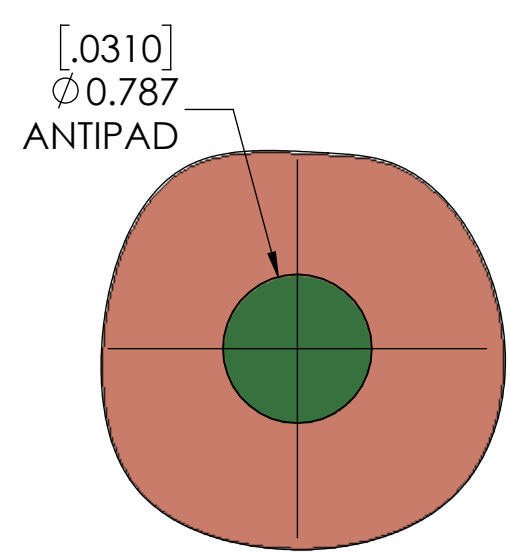

DETAIL B
SCALE 25:1
LAYER 3 (Cu)
VIAS NOT SHOWN FOR CLARITY

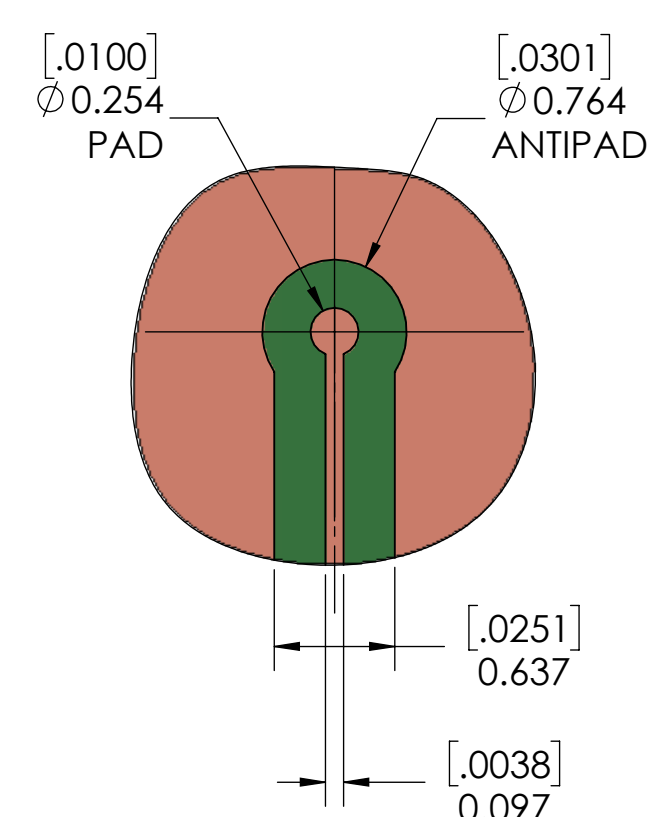

DETAIL B
SCALE 25:1
LAYER 5 (Cu)
VIAS NOT SHOWN FOR CLARITY

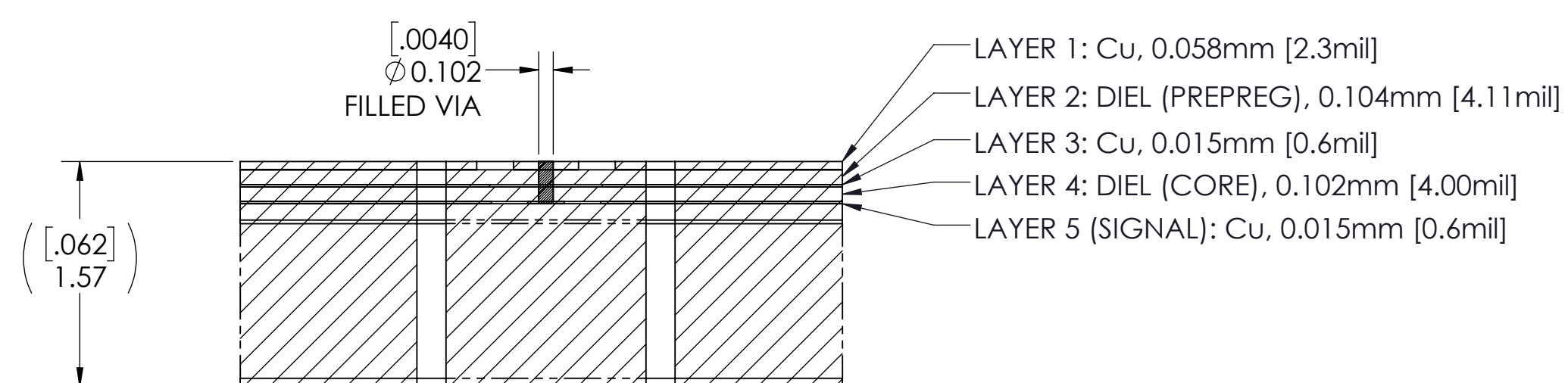
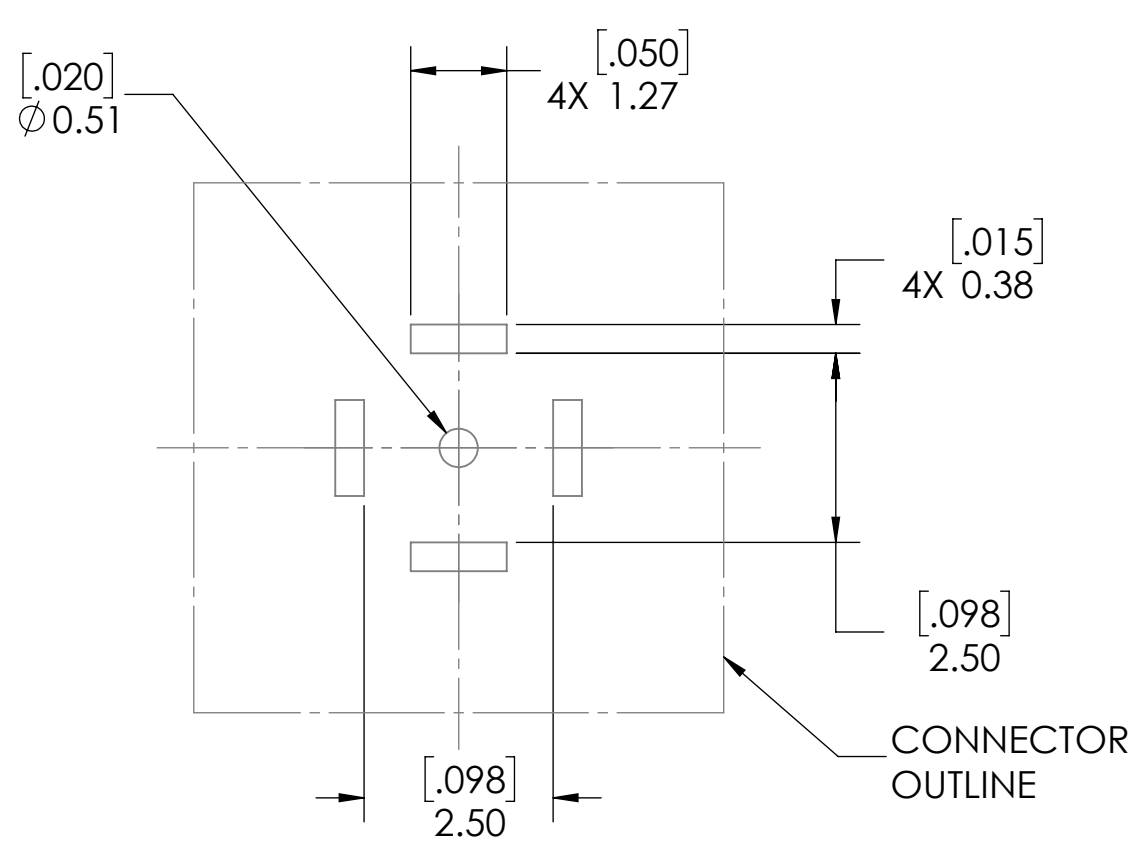
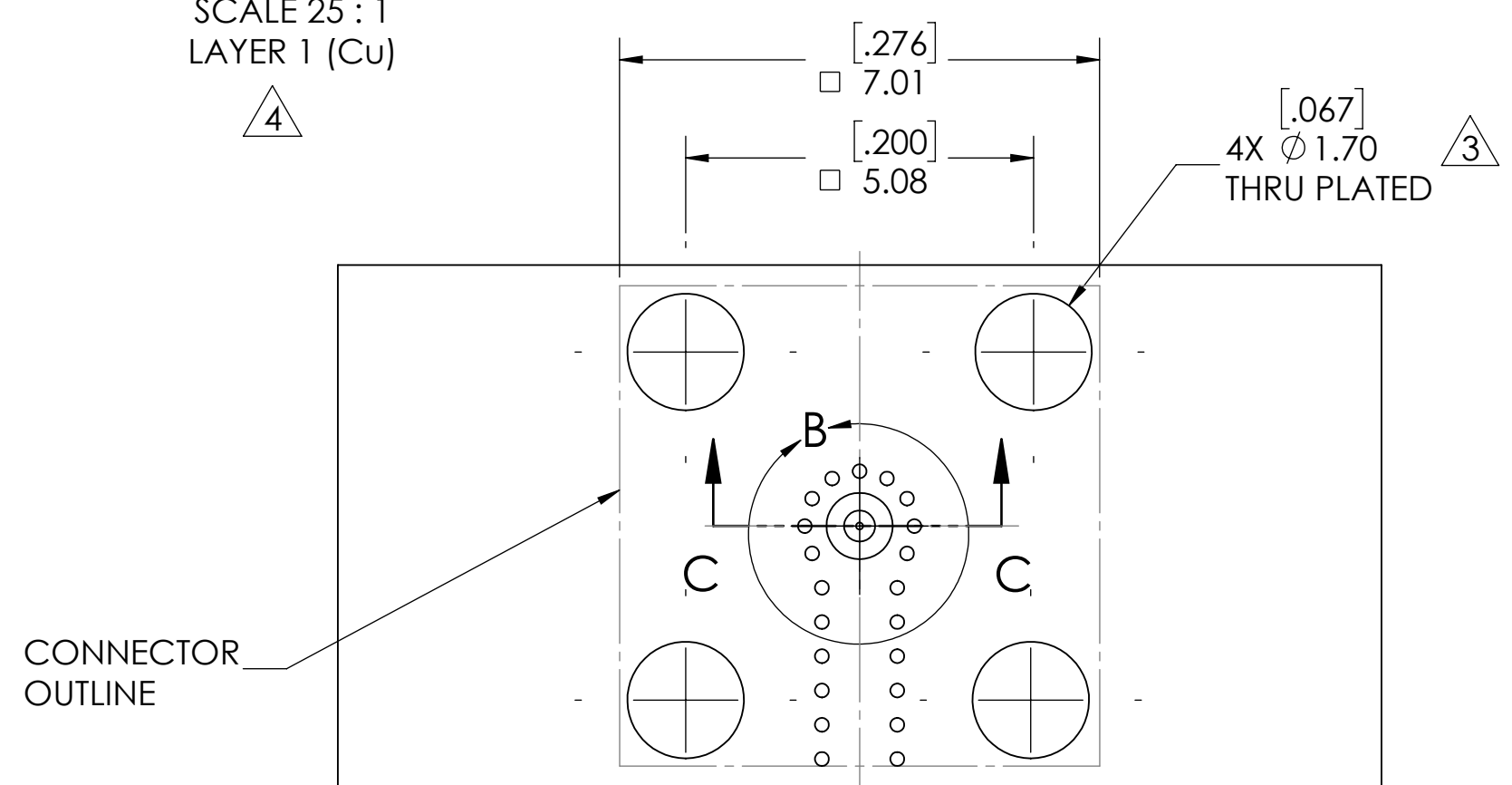

SOLDER PASTE STENCIL
SCALE 10:1

PCB LAYOUT
(FOR REFERENCE ONLY)

SECTION C-C
SCALE 25 : 1
PCB LAYER DEFINITION

SCALE	SUB-DIRECTORY/	SHEET 2 OF 2
10:1		
SIZE	CAGE CODE	DRAWING NO.
C		TMB-V5FS-3SM
		REV. 5