

THIS DRAWING IS UNPUBLISHED. RELEASED FOR PUBLICATION  
 © COPYRIGHT - By - ALL RIGHTS RESERVED.

LOC	DIST	REVISIONS			
P	LTR	DESCRIPTION	DATE	DWN	APVD
AD	00	R2	REVISED PER ECO-11-004820	11MAR11	RK HMR

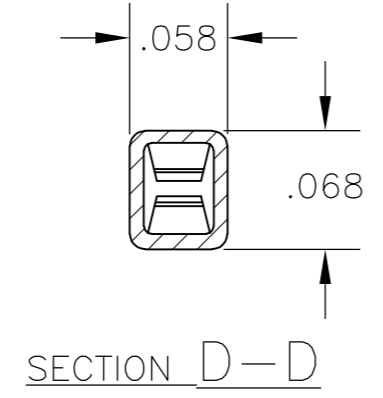
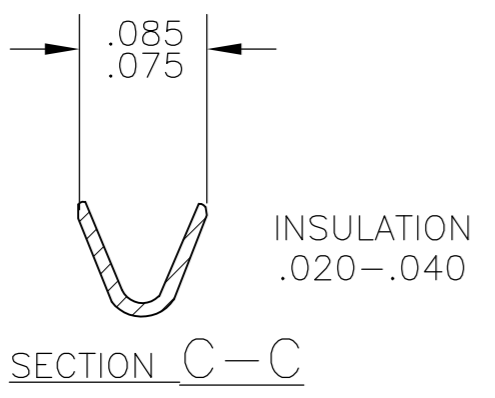
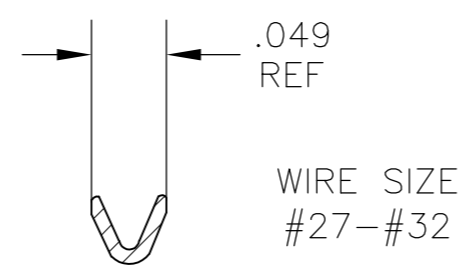
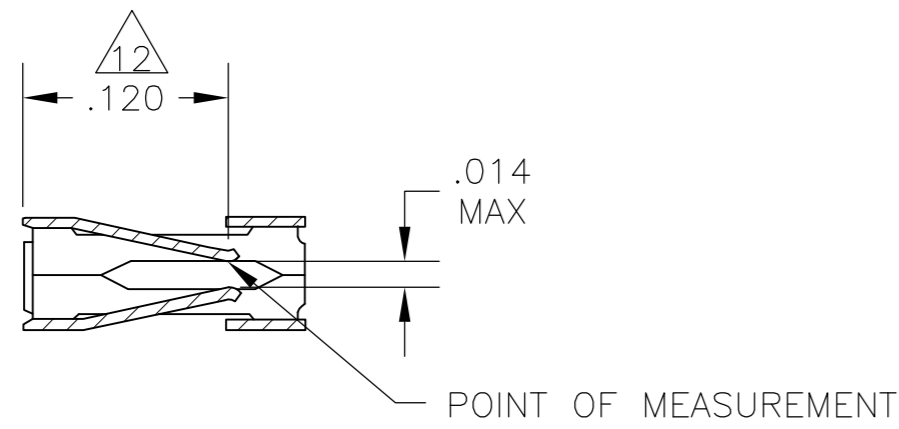
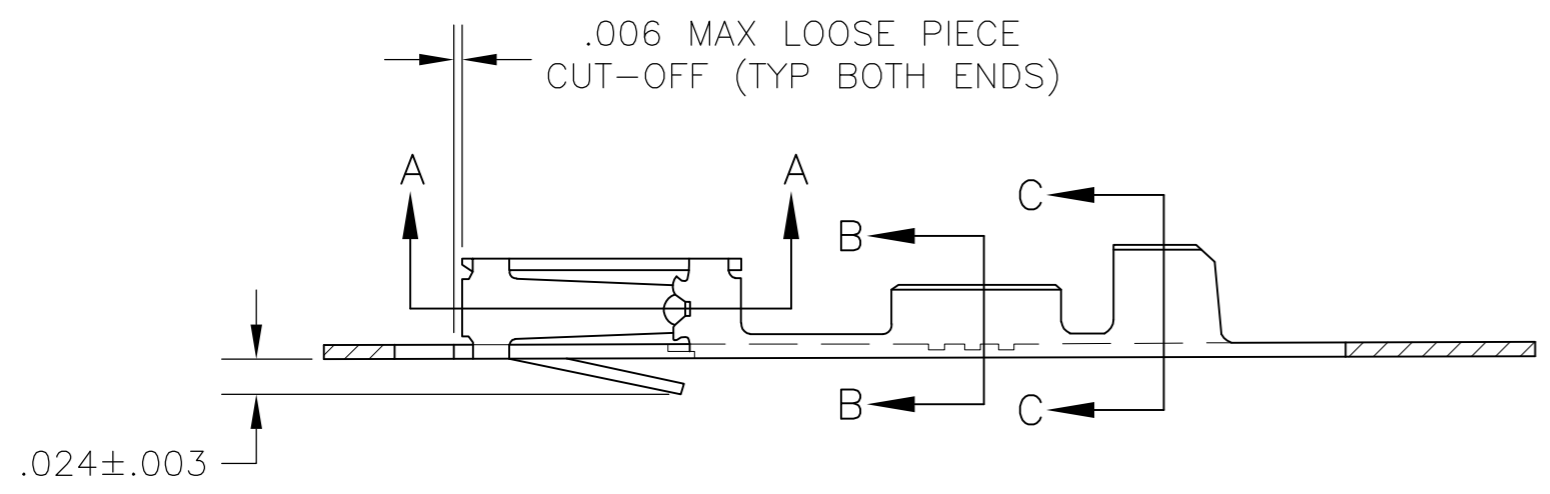
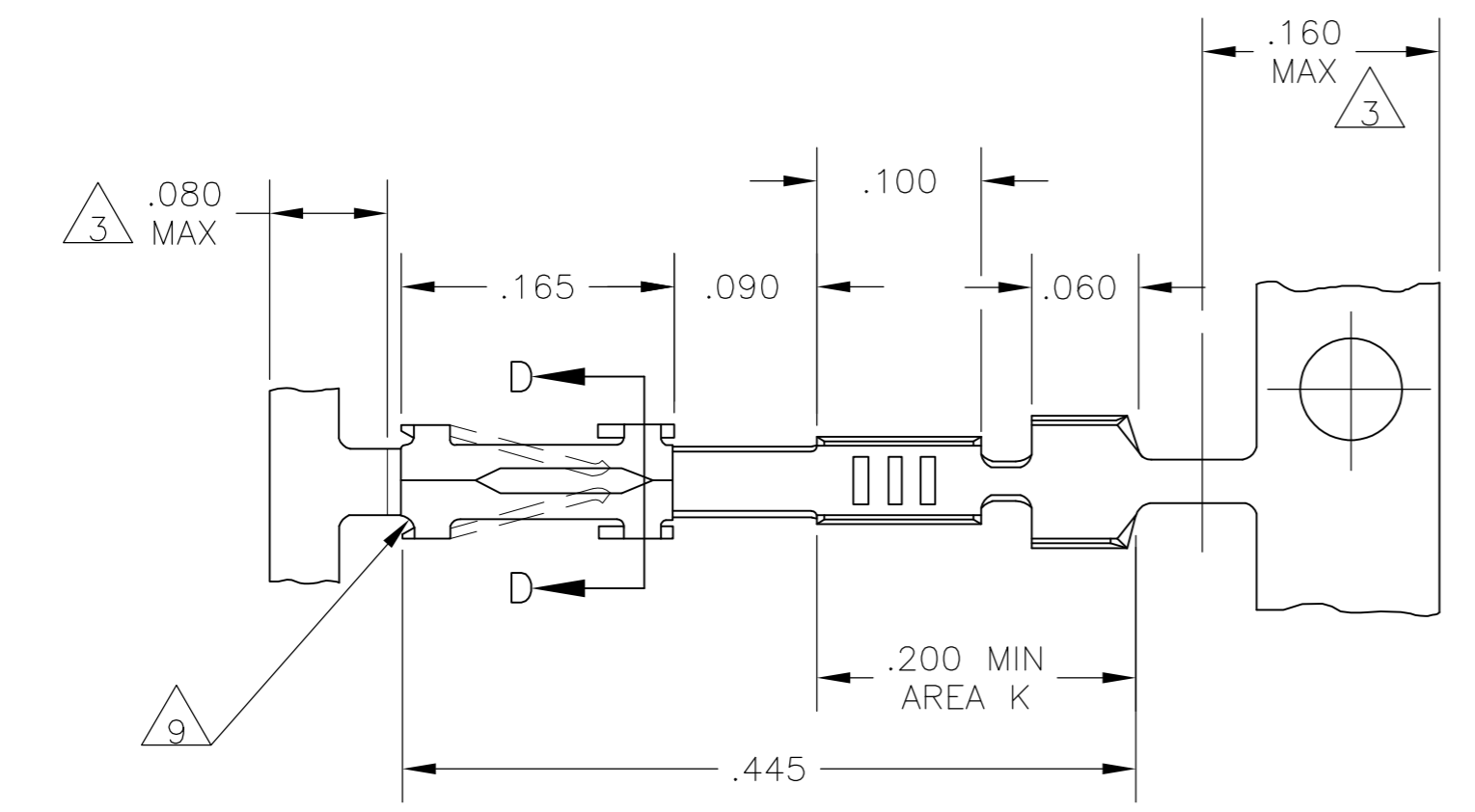

- 1 UNPLATED
- 2 .000030 GOLD ON CONTACT AREA, GOLD FLASH ON THE REMAINDER, ALL OVER .000050 NICKEL.
- 3 GOLD PLATING NOT REQUIRED THIS AREA.
- 4 .000050 NICKEL ENTIRE CONTACT, .000015 GOLD ON CONTACT AREA.
- 5 SHEARED EDGES PERMITTED TO BE UNPLATED.
- 6 PREPLATED .000050-.000150 BRIGHT TIN.
- 7 REELED FOR MINI APPLICATOR.
- 8 .000015 GOLD ON CONTACT AREA, .000100-.000200 BRIGHT TIN-LEAD ON AREA K, OVER .000050 NICKEL.
- 9 CUT OUTS ON BOX AT MANUFACTURER'S OPTION.
- 10 .000030 GOLD ON CONTACT AREA, .000100-.000200 BRIGHT TIN-LEAD IN AREA K, ALL OVER .000050 NICKEL.
- 12 POINT OF MEASUREMENT FOR PLATING THICKNESS (INSIDE BEAMS)
- 13 OBSOLETE PART NUMBER
- 14 .000015 GOLD ON CONTACT AREA, .000100-.000200 MATTE TIN ON AREA K, OVER .000050 NICKEL.
- 15 .000030 GOLD ON CONTACT AREA, .000100-.000200 MATTE TIN IN AREA K, ALL OVER .000050 NICKEL.

LOOSE PIECE PART NO	FINISH	PART NUMBER
6-102316-4	5/15	5-102316-8
6-102316-3	5/14	5-102316-6
1-102316-4	5/10	102316-8
1-102316-3	5/8	102316-6
1-102316-2	6	102316-5
1-102316-1	4/5	102316-3
1-102316-0	2	102316-2
---	1	102316-1

THIS DRAWING IS A CONTROLLED DOCUMENT.		DWN	15 NOV 78	<b>TE</b> TE Connectivity	
DIMENSIONS: INCHES		CHK	14 FEB 79		
TOLERANCES UNLESS OTHERWISE SPECIFIED:		APVD	20 FEB 79	NAME	
0 PLC	± -	PRODUCT SPEC		CONTACT, FEMALE, MOD IV CRIMP SNAP-IN	
1 PLC	± -	APPLICATION SPEC		SIZE	RESTRICTED TO
2 PLC	± -	MATERIAL		CAGE CODE	DRAWING NO
3 PLC	± 0.13 [.005]	FINISH		00779	
4 PLC	± -	SEE TABLE		SCALE	102316
ANGLES	± -	CUSTOMER DRAWING		8:1	SHEET 1 of 1
MATERIAL: CU-SN-P ALLOY 521 .008 THK		WEIGHT: -		REV R2	